

规格

■操作线圈额定值

额定电压	AC 100 V	AC 115 V/AC 120 V		AC 200 V	AC 230 V/AC 240 V	
50 Hz下的额定电流 (mA)	7.50	5.85	6.25	3.75	3.00	3.13
60 Hz下的额定电流 (mA)	6.88	5.35	5.70	3.45	2.76	2.88
线圈电阻(Ω)	8 220	11,600		33,000	47,600	
必要动作电压	额定电压75% (最大)					
必要复位电压	额定电压15% (最小)					
电压最大值	额定电压90%~110%					
功率消耗	约0.75 VA					

注: 1.以上项目是线圈温度在23°C时的值。
2.额定电流的公差为+15%/-20%。
3.功率消耗下降为50Hz。
4.线圈电阻为参考值。

额定电压	DC 5 V	DC 12 V	DC 24 V	DC 48 V
额定电流 (mA)	80.0	33.3	16.7	8.96
线圈电阻(Ω)	62.5	360	1,440	5,358
必要动作电压	额定电压70% (最大)			
必要复位电压	额定电压10% (最小)			
电压最大值	额定电压130%			
功率消耗	约0.4 W			约0.43 W

注: 1.以上项目是线圈温度在23°C时的值。
2.额定电流的公差为+10%。
3.“电压最大值”是应用在继电器线圈的最大电压。
不是连续应用的最大电压。

■额定接点

项目	标准型	高容量型
负载	阻性负载 (cosφ=1)	
额定负载	AC 250 V 12 A (NO), AC 250 V 5 A (NC) AC 250 V 16 A (NO), AC 250 V 5 A (NC) DC 24 V 12 A (NO), DC 24 V 5 A (NO) DC 24 V 16 A (NO), DC 24 V 5 A (NO)	
额定通电电流	12 A (NO), 5 A (NC)	16 A (NO), 5 A (NC)
接点电压的最大值	AC 250 V, DC 24 V	
接点电流的最大值	12 A (NO), 5 A (NC)	16 A (NO), 5 A (NC)
开关容量的最大值	AC 3,000 VA (NO), AC 1,250 VA (NC) DC 288 W (NO), DC 120 W (NC)	AC 4,000 VA (NO), AC 1,250 VA (NC) DC 384 W (NO), DC 120 W (NC)
最小容许负载	DC 5 V 100 mA (AC线圈类型: DC 24 V 40 mA)	

■ 国际标准规格认证

UL 508和CSA C22.2 No. 1, C22.2 No. 14

型号	操作线圈额定值	接点额定值
G5RL-1	DC 5~48 V	12 A, 277 VAC General, 80,000 c - NO 12 A, 250 VAC General, 80,000 c - NO 12 A, 24 VDC Resistive, 100,000 c - NO TV-5, 25,000 c - NO A 300 Pilot Duty, 720 VA, 240 VAC, 30,000 c - NO 1 Hp, 240 VAC, 6,000 c - NO 1/2 Hp, 120 VAC, 6,000 c - NO 60 LRA/10 FLA, 250 VAC, 6,000 c - NO 5 A, 250 VAC General, 50,000 c - NC 5 A, 24 VDC Resistive, 50,000 c - NC
G5RL-1A	DC 5~48 V	12 A, 277 VAC General, 80,000 c - NO 12 A, 250 VAC General, 80,000 c - NO 12 A, 24 VDC Resistive, 100,000 c - NO TV-5, 25,000 c - NO A 300 Pilot Duty, 720 VA, 240 VAC, 30,000 c - NO 1 Hp, 240 VAC, 6,000 c - NO 1/2 Hp, 120 VAC, 6,000 c - NO 60 LRA/10 FLA, 250 VAC, 6,000 c - NO
G5RL-1-E	DC 5~48 V AC 24~240 V	16 A, 277 VAC General, 50,000 c - NO 16 A, 250 VAC General, 50,000 c - NO 16 A, 24 VDC Resistive, 50,000 c - NO (DC Coil Models only) TV-5, 25,000 c - NO A 300 Pilot Duty, 720 VA, 240 VAC, 30,000 c - NO 1 Hp, 240 VAC, 6,000 c - NO (DC Coil Models only) 1/2 Hp, 120 VAC, 6,000 c - NO 60 LRA/10 FLA, 250 VAC, 6,000 c - NO 5 A, 250 VAC General, 50,000 c - NC 5 A, 24 VDC Resistive, 50,000 c - NC
G5RL-1A-E	DC 5~48 V	16 A, 277 VAC General, 50,000 c - NO 16 A, 250 VAC General, 50,000 c - NO 16 A, 24 VDC Resistive, 50,000 c - NO TV-5, 25,000 c - NO A 300 Pilot Duty, 720 VA, 240 VAC, 30,000 c - NO 1 Hp, 240 VAC, 6,000 c - NO 1/2 Hp, 120 VAC, 6,000 c - NO 60 LRA/10 FLA, 250 VAC, 6,000 c - NO

G
5
R
L

VDE DIN EN 61810-1第二版和EN60255-25 (No. A662)

型号	操作线圈额定值	接点额定值
G5RL-1(A)	DC 5, 12, 24, 48 V	AC 12A, 250 V, 40,000(NO) 20,000(CO) DC 12A, 24 V, 100,00 (NO, CO)
G5RL-1(A)-E	DC 5, 12, 24, 48 V	AC 16A, 250 V, 15,000(NO) 10,000(CO) DC 16A, 24 V, 5,000 (NO, CO)
G5RL-1-E	AC 24, 100, 115/120, 200, 230/240 V (50 Hz)	AC 16A, 250 V 15,000 c

■特性

项目	标准型	高容量型
接触电阻	100 mΩ以下	
操作时间	15 ms以下 (AC线圈型: 20 ms以下)	
复位时间	5 ms以下 (AC线圈型: 20 ms以下)	
开关频率的最大值	机械: 18,000 次/h 电气: 1,800 次/h (额定负载下)	
绝缘电阻	1,000 MΩ以上 (DC 500 V下)	
绝缘抵抗	同极接点之间 AC 1,000 V, 50/60 Hz 1 min 线圈和接点之间 AC 6,000 V, 50/60 Hz 1 min	
耐电压	线圈和接点之间 10,000 V, 1.2×50 μs	
振动	误动作: 10 ~ 55 ~ 10 Hz, 双振幅1.5-mm 耐久: 10~55~10 Hz, 双振幅1.5-mm	
冲击	误动作: 1,000 m/s ² (约100 G) 耐久: 100 m/s ² (约10 G)	
寿命	机械: 10,000,000次以上 (18,000 次/h的情况下)	
	电气 50,000 次以上 AC 250 V 5 A (NC) DC 24 V 5 A (NC) 100,000次以上 AC 250 V 12 A (NO) DC 24 V 12 A (NO)	电气 50,000次以上 AC 250 V 5 A (NC) (只用于AC线圈型) DC 24 V 5 A (NC) (只用于AC线圈型) 50,000次以上 AC 250 V 16 A (NO) DC 24 V 16 A (NO) 100,000次以上 AC 250 V 12 A (NO) (只用于DC线圈型)
使用环境温度	操作: -40°C~70°C (AC线圈型), -40°C~85°C (DC线圈型)	
使用环境湿度	操作: 5%~85%	
重量	约10g	

工程数据

寿命

G5RL-1-E

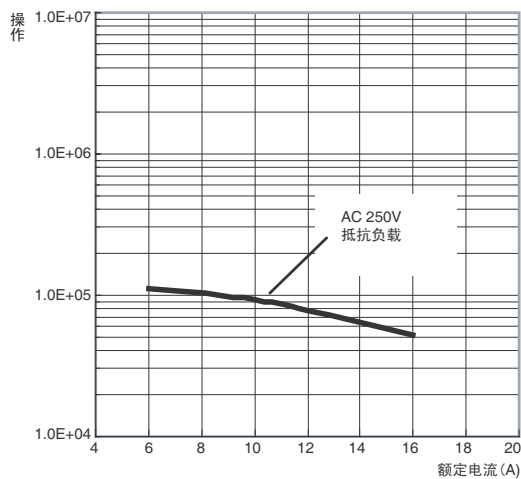

■外形尺寸

注：除非标明，否则所有单位为毫米。

G5RL-1

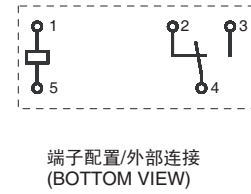
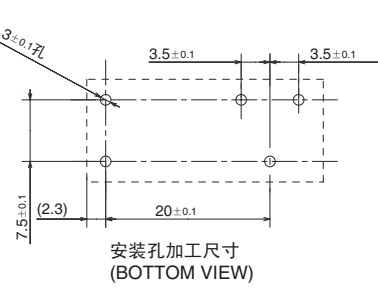
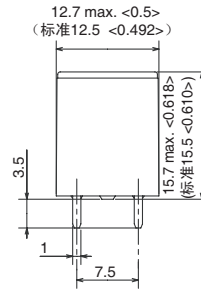
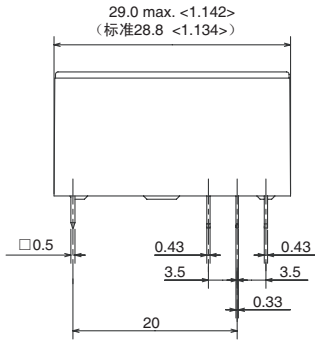
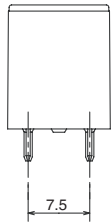
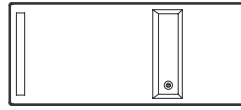
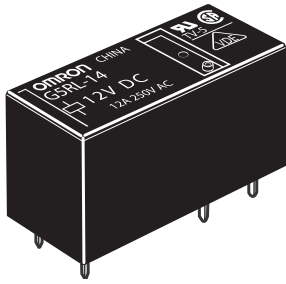

<> 英寸

G5RL

G5RL-1A

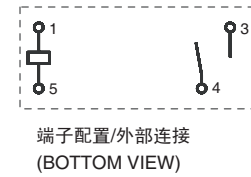
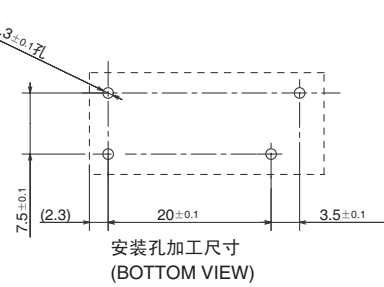
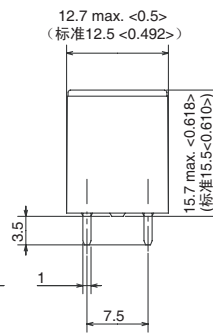
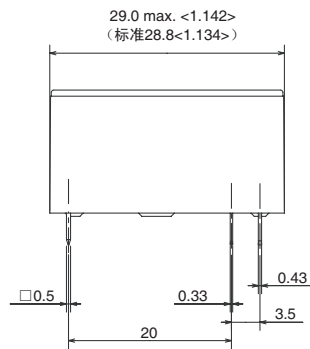
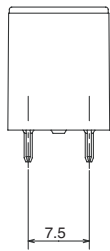
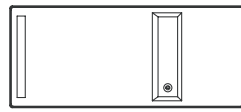
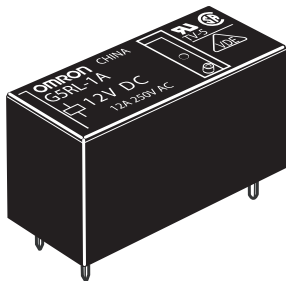

<> 英寸

G5RL-1-E

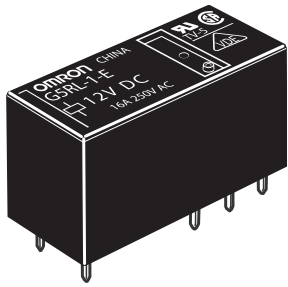

*指定为平均尺寸

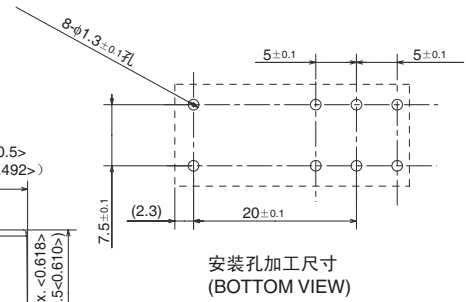
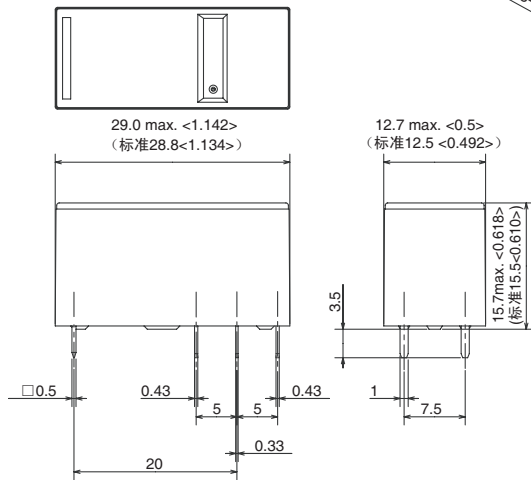
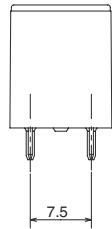

安装孔加工尺寸
(BOTTOM VIEW)

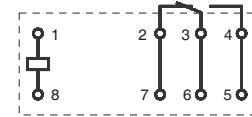

端子配置/外部连接
(BOTTOM VIEW)

<> 英寸

G5RL-1A-E

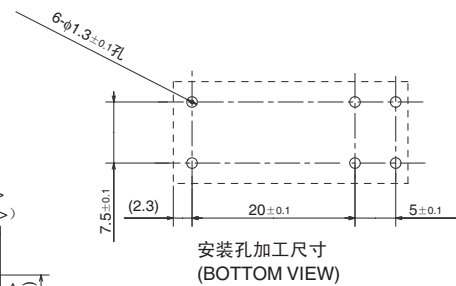
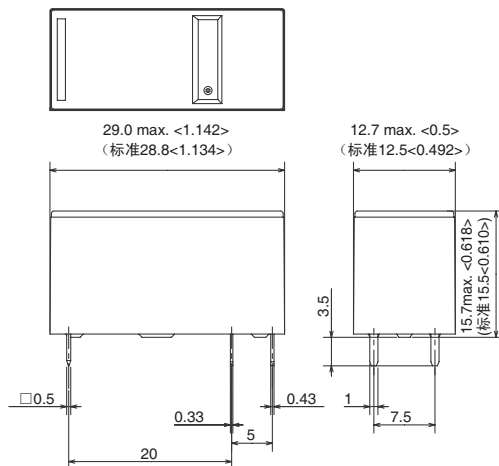
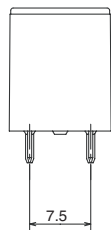
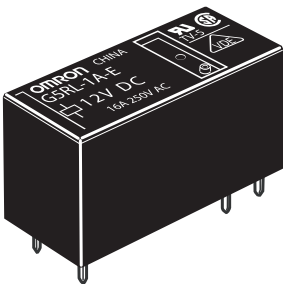

安装孔加工尺寸
(BOTTOM VIEW)

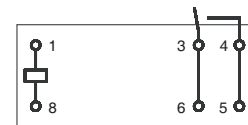

端子配置/外部连接
(BOTTOM VIEW)

<> 英寸

包装

注：除非标明否则所有单位为毫米。

■聚苯乙烯盘包装

- 1 聚苯乙烯盘 = 100 继电器
- 1 套筒 = 5 聚苯乙烯盘
- 1 纸板箱 = 2 套筒
- = 1,000 继电器
- 重量 = 约12kg/箱
- 聚苯乙烯盘尺寸: 340×120×48 mm (L×W×H)
- 纸板箱尺寸: 535×355×250 mm (L×W×H)

