

P.C.B. LAYOUT

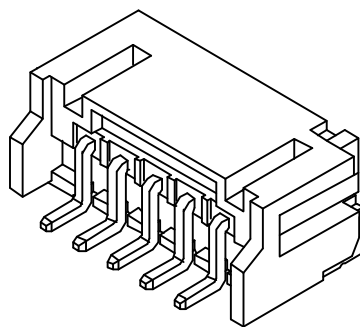

◆SPECIFICATIONS

- Current rating: 2A AC, DC
- Voltage rating: 100V AC,DC
- Temperature range: -25°C ~ +85°C
- Insulation resistance: 1000MΩ Min.
- Withstanding voltage: 800V AC/ minute.
- Contact resistance: 10m Ω Max.

Material:

Insulator: Nylon 9T UL 94V-0
 Contact: Brass
 Solder Nail: Brass
 Plating: Tin plated over Nickel
 Circuits: 2~16
 Mate: KR2001 series Housing

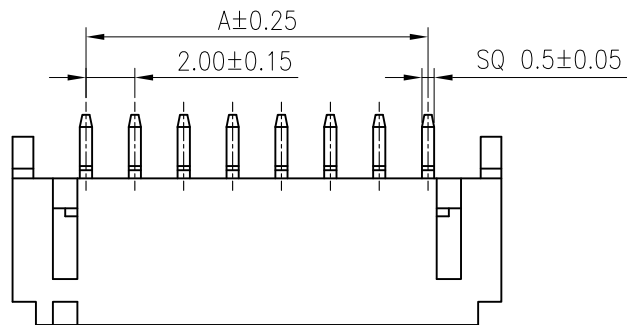

C2001RS00284P920

002代表2P

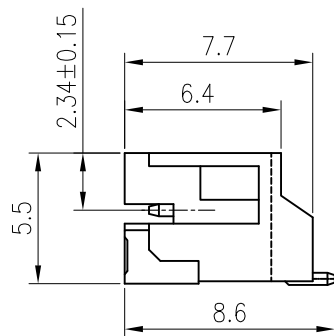
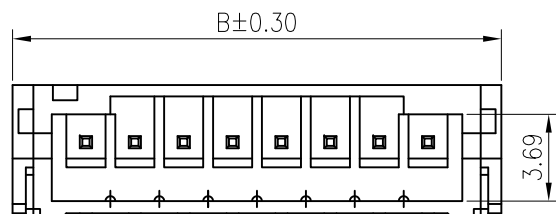

PART No.	Dimension	
	A	B
C2001RS00284P92W	2.00	8.00
C2001RS00384P92W	4.00	10.00
C2001RS00484P92W	6.00	12.00
C2001RS00584P92W	8.00	14.00
C2001RS00684P92W	10.00	16.00
C2001RS00784P92W	12.00	18.00
C2001RS00884P92W	14.00	20.00
C2001RS00984P92W	16.00	22.00
C2001RS01084P92W	18.00	24.00
C2001RS01184P92W	20.00	26.00
C2001RS01284P92W	22.00	28.00
C2001RS01384P92W	24.00	30.00
C2001RS01484P92W	26.00	32.00
C2001RS01584P92W	28.00	34.00
C2001RS01684P92W	30.00	36.00

④				GENERAL TOLERANCE	UNIT: mm	DATE	TITLE:		
③				.X±0.30	X°±1°	DRAWN: 朱佑武	JST PH 2.0 SMT		
②				.XX±0.20	.X°±	CHECKED:	90° Wafer		
①				.XXX±0.10	.XX°±	APPROVED:	VER.	SCALE:	N/A
LTR	NAME	DATE	VERSION RECORD				A	SHEET:	1/1

 东莞市康瑞电子有限公司
 DongGuan A Rui Electronic Co., LTD.

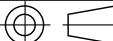
PROJECTION	PART NO.	C2001RS***84P920	
	DRAWING NO.	2001WHS01-8-S	

1

2

3

4

5

6

7

8

9

A

B

C

D

E

F

1

2

3

4

5

6

7

8

9