



### 1. General Description

This EPROM-Based 8bit micro-controller uses a fully static CMOS technology process to achieve higher speed and smaller size with the low power consumption and high noise immunity. On chip memory includes 1K words of ROM, and 68 bytes of static RAM.

### 2. Features

The followings are some of the features on the hardware and software :

- ◆ Fully CMOS static design
- ◆ 8-bit data bus
- ◆ On chip EPROM size : 1.0 K words
- ◆ Internal RAM size : 84 bytes  
(68 general purpose registers, 16 special registers)
- ◆ 37 single word instructions
- ◆ 14-bit instructions
- ◆ 8-level stacks
- ◆ Operating voltage : 2.5 V ~ 5.5 V (PRD Disable)  
4.5 V ~ 5.5 V (PRD Enable)
- ◆ Operating frequency : DC ~ 20 MHz
- ◆ The most fast execution time is 200 ns under 20 MHz in all single cycle instructions except the branch instruction
- ◆ Addressing modes include direct, indirect and relative addressing modes
- ◆ Power-on Reset
- ◆ Power edge-detector Reset
- ◆ Power range-detector Reset
- ◆ Sleep Mode for power saving
- ◆ Four interrupt sources:
  - External INT pin
  - TMR0 timer
  - A/D conversion completion
  - PortB<7:4> interrupt on change

- ◆ A/D converter module:
  - Four analog inputs multiplexed into one A/D converter
  - 8-bit resolution
- ◆ 4 types of oscillator can be selected by programming option:
  - RC - Low cost RC oscillator
  - LFXT - Low frequency crystal oscillator
  - XTAL - Standard crystal oscillator
  - HFXT - High frequency crystal oscillator
- ◆ 8-bit real time clock/counter(RTCC) with 8-bit programmable prescaler
- ◆ On-chip RC oscillator based Watchdog Timer(WDT)
- ◆ 13 I/O pins with their own independent direction control

### 3. Applications

The application areas of this MDT2051 range from appliance motor control and high speed automotive to low power remote transmitters/receivers, pointing devices, and telecommunications processors, such as Remote controller, small instruments, chargers, toy, automobile and PC peripheral ... etc.

**4. Pin Assignment**

				SSOP			
PA2/AIC2	1	18	PA1/AIC1	PA2	1	20	PA1
PA3/AIC3	2	17	PA0/AIC0	PA3	2	19	PA0
PA4/RTCC	3	16	OSC1	RTCC	3	18	OSC1
/MCLR	4	15	OSC2	/MCLR	4	17	OSC2
V <sub>ss</sub>	5	14	V <sub>dd</sub>	VSS	5	16	VDD
PB0/INT	6	13	PB7	VSS	6	15	VDD
PB1	7	12	PB6	PB0	7	14	PB7
PB2	8	11	PB5	PB1	8	13	PB6
PB3	9	10	PB4	PB2	9	12	PB5
				PB3	10	11	PB4

**5. Pin Function Description**

Pin Name	I/O	Function Description
PA0~PA3	I/O	Port A, TTL input level / Analog input channel
PB0~PB7	I/O	Port B, TTL input level / PB0:External interrupt input , PB4~PB7:Interrupt on pin change
RTCC/PA4	I/O	Real Time Clock/Counter, Schmitt Trigger input levels Open drain output
/MCLR	I	Master Clear, Schmitt Trigger input levels
OSC1	I	Oscillator Input
OSC2	O	Oscillator Output
V <sub>dd</sub>		Power supply
V <sub>ss</sub>		Ground

**6. Memory Map**

(A) Register Map

Address	Description
BANK0	
00	Indirect Addressing Register
01	RTCC
02	PCL
03	STATUS
04	MSR

Address	Description
05	Port A
06	Port B
08	ADS0
09	ADRES
0A	PCHLAT
0B	INTS
0C~4F	General purpose register
BANK1	
01	TMR
05	CPIO A
06	CPIO B
07	PSTA
08	ADS1

(1)IAR ( Indirect Address Register) : R00

(2)RTCC (Real Time Counter/Counter Register) : R01

(3) PC (Program Counter) : R02,R0A

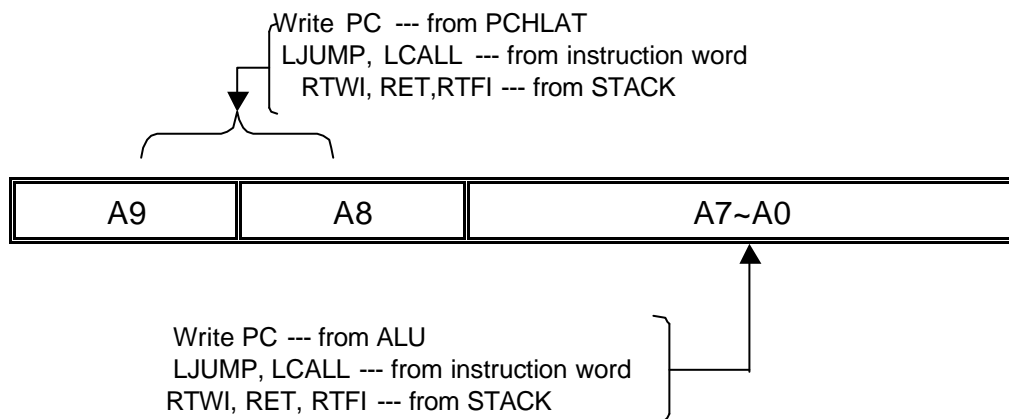

(4) STATUS (Status register) : R03

Bit	Symbol	Function
0	C	Carry bit
1	HC	Half Carry bit
2	Z	Zero bit
3	PF	Power down Flag bit
4	TF	WDT Timer overflow Flag bit
5	RBS0	Register Bank Select bit : 0 : 00H --- 7FH 1 : 80H --- FFH
7~6	—	General purpose bit

(5) MSR (Memory Bank Select Register) : R4

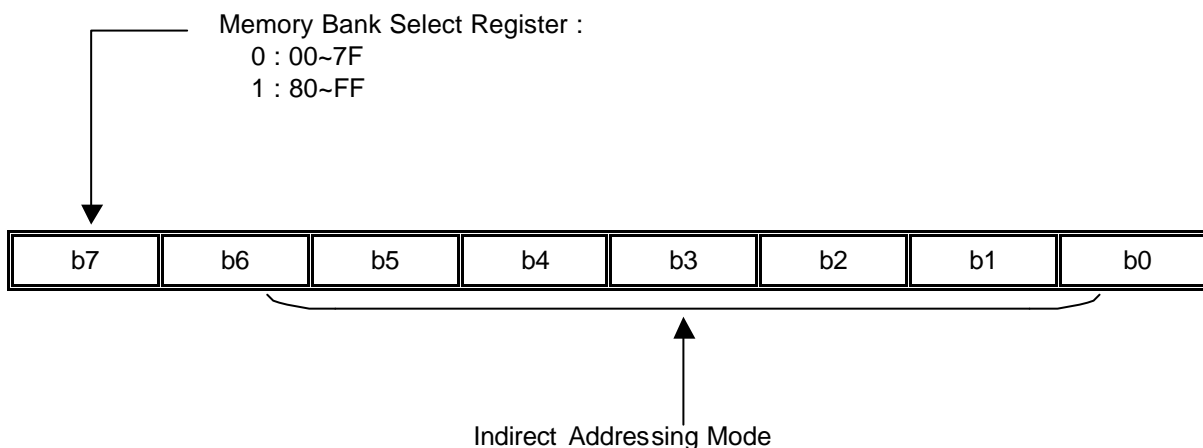

(6) PORT A : R05

PA4~PA0, I/O Register

(7) PORT B : R06

PB7~PB0, I/O Register

(8) ADS0 ( A/D Status Register ) : R08

Bit	Symbol	Function
0	ADRUN	0 : A/D converter module is shut off and consumes no operating current 1 : A/D converter module is operating
1	ADIF	A/D conversion complete interrupt flag bit Set when conversion is completed. Reset in software.
2	GO/DONEB	GO/DONEB must be set to begin a conversion . It is automatically reset in hardware when the conversion is complete
4,3	CHS1-0	00 : AIC0 01 : AIC1 10 : AIC2 11 : AIC3
5	Reserved	Can be used as a general purpose r/w bit
7,6	ASCS1-0	00 : fosc/2 01: fosc/8 10 : fosc/32 11 : f RC (*Note)

\*Note: determined by OSC mode, HF: fosc/32 XT: fosc/8 RC: fosc/2 LF: fosc/2

(9) ADRES ( A/D result register ) : R09

(10)PCHLAT : R0A

(11) INTS ( Interrupt Status Register ) : R0B

Bit	Symbol	Function
0	RBIF	PORT B change interrupt flag. Set when PB <7:4> inputs change
1	INTF	Set when INT interrupt occurs. INT interrupt flag.
2	TIF	Set when TMR overflows.
3	RBIE	0 : disable PB change interrupt 1 : enable PB change interrupt
4	INTS	0 : disable INT interrupt 1 : enable INT interrupt
5	TIS	0 : disable TMR interrupt 1 : enable TMR interrupt
6	ADIS	0 : disable A/D interrupt 1 : enable A/D interrupt
7	GIS	0 : disable global interrupt 1 : enable global interrupt

(12) TMR (Time Mode Register) : R81

Bit	Symbol	Function		
2—0	PS2—0	Prescaler Value	RTCC rate	WDT rate
		0 0 0	1 : 2	1 : 1
		0 0 1	1 : 4	1 : 2
		0 1 0	1 : 8	1 : 4
		0 1 1	1 : 16	1 : 8
		1 0 0	1 : 32	1 : 16
		1 0 1	1 : 64	1 : 32
		1 1 0	1 : 128	1 : 64
1 1 1	1 : 256	1 : 128		
3	PSC	Prescaler assignment bit : 0 — RTCC 1 — Watchdog Timer		
4	TCE	RTCC signal Edge : 0 — Increment on low-to-high transition on RTCC pin 1 — Increment on high-to-low transition on RTCC pin		

Bit	Symbol	Function
5	TCS	RTCC signal set : 0 — Internal instruction cycle clock 1 — Transition on RTCC pin
6	IES	Interrupt edge select 0 — Interrupt on falling edge on PB0 1 — Interrupt on rising edge on PB0
7	PBPH	PORTB pull-hi 0 — PORTB pull-hi are enable 1 — PORTB pull-hi are disable

(13) CPIO A (Control Port I/O Mode Register) : R85  
= "0", I/O pin in output mode;  
= "1", I/O pin in input mode.

(14) CPIO B (Control Port I/O Mode Register) : R86  
= "0", I/O pin in output mode;  
= "1", I/O pin in input mode.

(15) PSTA : R87

Bit	Symbol	Function
0	PRDB	0:Power range-detector Reset occurred 1:No Power range-detector Reset Occurred
1	PORB	0:Power on Reset occurred 1:No Power on Reset occurred

(16) ADS1 ( A/D Status Register ) : R88

Bit	Symbol	Function
1,0	PAVM1-0	00 : PA0 - 3 = analog input . VREF = VDD 01 : PA0 - 2 = analog input . PA3 =ref input, VREF =PA3 10 : PA0 - 1 = analog input. PA2-3 = digital I/O ,VREF = VDD 11 : PA0 - 3 = digital I/O , VREF = VDD

(17) Configurable options for EPROM (Set by writer) :

Oscillator Type
RC Oscillator
HFXT Oscillator
XTAL Oscillator
LFXT Oscillator

<b>Watchdog Timer control</b>
Watchdog timer disable all the time
Watchdog timer enable all the time

<b>Power-range control</b>
Power-range disable
Power-range enable

<b>Oscillator-start Timer control</b>
0ms
75ms

<b>Power-edge Detect</b>
PED Disable
PED Enable

<b>Security state</b>
Security weak Disable
Security Disable
Security Enable

The default security state of EPROM is weak disable. Once the IC was set to enable or disable, it's forbidden to change.

(B) Program Memory

Address	Description
000-3FF	Program memory
000	The starting address of power on, external reset or WDT time-out reset.
004	Interrupt vector

**7. Reset Condition for all Registers**

Register	Address	Power-On Reset, Power range detector Reset	/MCLR or WDT Reset	Wake-up from SLEEP
IAR	00h	-	-	-
RTCC	01h	xxxx xxxx	uuuu uuuu	uuuu uuuu
PC	0Ah,02h	00 0000 0000	00 0000 0000	PC+1
STATUS	03h	0001 1xxx	000# #uuu	000# #uuu
MSR	04h	xxxx xxxx	uuuu uuuu	uuuu uuuu
PORT A	05h	-- -1 xxxx	-- -1 uuuu	-- -u uuuu

*This specification are subject to be changed without notice. Any latest information please preview*

Register	Address	Power-On Reset, Power range detector Reset	/MCLR or WDT Reset	Wake-up from SLEEP
PORT B	06h	xxxx xxxx	uuuu uuuu	uuuu uuuu
ADS0	08h	00-0 0000	00-0 0000	uu-u uuuu
ADRES	09h	xxxx xxxx	uuuu uuuu	uuuu uuuu
INTS	0Bh	0000 0001	0000 000u	uuuu uuuu
TMR	81h	1111 1111	1111 1111	uuuu uuuu
CPIOA	85h	- - -1 1111	- - -1 1111	- - -u uuuu
CPIOB	86h	1111 1111	1111 1111	uuuu uuuu
PSTA	87h	- - - - - -qq	- - - - - -uu	- - - - - -uu
ADS1	88h	- - - - - -00	- - - - - -00	- - - - - -uu

Note : u = unchanged, x = unknown, - = unimplemented, read as "0"

# = value depends on the condition of the following table

Condition	Status: bit 4	Status: bit 3	Status: bit 1	Status: bit 0
/MCLR reset (not during SLEEP)	u	u	1	1
/MCLR reset during SLEEP	1	0	1	1
WDT reset (not during SLEEP)	0	1	1	1
WDT reset during SLEEP	0	0	1	1
Power on reset	1	1	0	X
Power range-detector Reset	1	1	1	0

**8. Instruction Set :**

Instruction Code	Mnemonic Operands	Function	Operating	Status
010000 00000000	NOP	No operation	None	
010000 00000001	CLRWT	Clear Watchdog timer	0 WT	TF, PF
010000 00000010	SLEEP	Sleep mode	0 WT, stop OSC	TF, PF
010000 00000011	TMODE	Load W to TMODE register	W TMODE	None
010000 00000100	RET	Return from subroutine	Stack PC	None
010000 00000rrr	CPIO R	Control I/O port register	W CPIO r	None
010001 1rrrrrrr	STWR R	Store W to register	W R	None
011000 trrrrrrr	LDR R, t	Load register	R t	Z
111010 iiiiii	LDWI I	Load immediate to W	I W	None
010111 trrrrrrr	SWAPR R, t	Swap halves register	[R(0-3) ↔ R(4-7)] t	None

This specification are subject to be changed without notice. Any latest information please preview



Instruction Code	Mnemonic Operands	Function	Operating	Status
011001 trrrrrr	INCR R, t	Increment register	R + 1 t	Z
011010 trrrrrr	INCRSZ R, t	Increment register, skip if zero	R + 1 t	None
011011 trrrrrr	ADDWR R, t	Add W and register	W + R t	C, HC, Z
011100 trrrrrr	SUBWR R, t	Subtract W from register	R - W t or (R+/W+1 t)	C, HC, Z
011101 trrrrrr	DECR R, t	Decrement register	R - 1 t	Z
011110 trrrrrr	DECRSZ R, t	Decrement register, skip if zero	R - 1 t	None
010010 trrrrrr	ANDWR R, t	AND W and register	R W t	Z
110100 iiiiiii	ANDWI i	AND W and immediate	i W W	Z
010011 trrrrrr	IORWR R, t	Inclu. OR W and register	R W t	Z
110101 iiiiiii	IORWI i	Inclu. OR W and immediate	i W W	Z
010100 trrrrrr	XORWR R, t	Exclu. OR W and register	R W t	Z
110110 iiiiiii	XORWI i	Exclu. OR W and immediate	i W W	Z
011111 trrrrrr	COMR R, t	Complement register	/R t	Z
010110 trrrrrr	RRR R, t	Rotate right register	R(n) R(n-1), C R(7), R(0) C	C
010101 trrrrrr	RLR R, t	Rotate left register	R(n) r(n+1), C R(0), R(7) C	C
010000 1xxxxxxx	CLRW	Clear working register	0 W	Z
010001 0rrrrrrr	CLRR R	Clear register	0 R	Z
0000bb brrrrrrr	BCR R, b	Bit clear	0 R(b)	None
0010bb brrrrrrr	BSR R, b	Bit set	1 R(b)	None
0001bb brrrrrrr	BTSC R, b	Bit Test, skip if clear	Skip if R(b)=0	None
0011bb brrrrrrr	BTSS R, b	Bit Test, skip if set	Skip if R(b)=1	None
100nnn nnnnnnnn	LCALL n	Long CALL subroutine	n PC, PC+1 Stack	None
101nnn nnnnnnnn	LJUMP n	Long JUMP to address	n PC	None
110111 iiiiiii	ADDWI i	Add immediate to W	W+i W	C,HC,Z
110001 iiiiiii	RTWI i	Return, place immediate to W	Stack PC,i W	None
111000 iiiiiii	SUBWI i	Subtract W from immediate	i-W W	C,HC,Z
010000 00001001	RTFI	Return from interrupt	Stack PC,1 GIS	None

Note :

W	: Working register	b	: Bit position
WT	: Watchdog timer	t	: Target
TMODE	: TMODE mode register	0	: Working register
CPIO	: Control I/O port register	1	: General register
TF	: Timer overflow flag	R	: General register address
PF	: Power loss flag	C	: Carry flag
PC	: Program Counter	HC	: Half carry
OSC	: Oscillator	Z	: Zero flag

This specification are subject to be changed without notice. Any latest information please preview

Inclu.	:	Inclusive ' '	/	:	Complement
Exclu.	:	Exclusive ' '	x	:	Don' t care
AND	:	Logic AND ' '	i	:	Immediate data ( 8 bits )
			n	:	Immediate address

**9. Electrical Characteristics**

\*Note: Temperature=25°C

1.Operation Current :

(1) HF (C=10p) , WDT - enable, PRD – disable

	4M	10M	20M	Sleep	Sleep , WDT-disable , PRD-disable
2.5V	200u	500u	900u	1u	1u
3.0V	300u	680u	1.1m	3u	1u
4.0V	530u	1.0m	1.7m	8u	1u
5.0V	800u	1.5m	2.5m	20u	1u
6.4V	1.4m	2.5m	3.8m	45u	1u

These parameters are for reference only.

(2) XT (C=10p) , WDT - enable, PRD – disable

	1M	4M	10M	Sleep	Sleep , WDT-disable , PRD-disable
2.5V	50u	150u	300u	1u	1u
3.0V	100u	280u	550u	3u	1u
4.0V	220u	500u	1m	8u	1u
5.0V	400u	800u	1.3m	20u	1u
6.4V	720u	1.3m	2.1m	45u	1u

These parameters are for reference only.

(3) RC, WDT - Enable; PRD - Disable; @Vdd = 5.0V

C	R	Freq.	Current	Sleep , WDT-disable , PRD-disable
3p	4.7k	12.4M	1.6m	1u
	10k	6.3M	900u	1u
	47k	1.42M	250u	1u
	100k	715K	160u	1u
	300k	235K	110u	1u
	470k	146K	90u	1u

C	R	Freq.	Current	Sleep , WDT-disable , PRD-disable
20p	4.7k	5.8M	900u	1u
	10k	2.9M	500u	1u
	47k	660K	180u	1u
	100k	318K	120u	1u
	300k	105K	90u	1u
	470k	66K	85u	1u
100p	4.7k	1.75M	320u	1u
	10k	880K	200u	1u
	47k	190K	110u	1u
	100k	92K	95u	1u
	300k	31K	90u	1u
	470k	19K	85u	1u
300p	4.7k	800K	180u	1u
	10k	380K	130u	1u
	47k	83K	100u	1u
	100k	39K	95u	1u
	300k	13K	90u	1u
	470k	8K	85u	1u

These parameters are for reference only.

(4) LF (C=10p) , WDT - disable, PRD - disable,

	32K	455K	1M	Sleep
2.5V	5u	35u	50u	1u
3.0V	6u	40u	70u	1u
4.0V	12u	65u	110u	1u
5.0V	30u	100u	150u	1u
6.4V	130u	165u	250u	1u

These parameters are for reference only.

2. Input Voltage (Vdd = 5V) :

	Port	Min	Max
Vil	TTL	Vss	1.0V
	Schmitt trigger	Vss	0.6V
Vih	TTL	2.2V	Vdd
	Schmitt trigger	3.5V	Vdd

These parameters are for reference only.

3. Output Voltage (Vdd = 5V) :

	PA,PB	Condition
Voh	4.0V	Ioh = -20mA
Vol	0.7V	Iol = 20mA
Voh	4.4V	Ioh = -5mA
Vol	0.3v	Iol = 5mA

These parameters are for reference only.

4. Output Current (Max.) (Vdd = 5V) :

Port A:	Current
source current	30mA
sink current	50mA

These parameters are for reference only.

Port B:	Current
source current	30mA
sink current	50mA

These parameters are for reference only.

5. The basic WDT time-out cycle time :

	Time
2.5V	25
3.0V	23
4.0V	20
5.0V	18
6.3V	16

Unit = ms

These parameters are for reference only.

6. PRD :

(1)PRD reset voltage :

	Voltage
Vh	4.0±5%
VI	3.6±5%

Unit = V

These parameters are for reference only.

(2) PRD reset current :

	Current
4.0V	100
3.6V	80

Unit = Ua

These parameters are for reference only.

7. Min Operation Voltage :

C =>	10p	20p	30p
XT, 20M	2.5	3.0	3.3
HF, 20M	2.5	2.8	3.0

Unit = V

These parameters are for reference only

RC, 1k, no cap.	2.5
-----------------	-----

Unit = V

These parameters are for reference only.

C =>	0p	10p	20p
LF, 1M	2.5	2.5	2.5

Unit = V

These parameters are for reference only.

8. MCLR filter time :

Vdd=5V	
Time	720

Unit = ns

These parameters are for reference only.

9.PB pull-high resistor

5V	50+-20%Kohm
3V	100+-20%Kohm

These parameters are for reference only.