



KBJ4005G THRU KBJ410G

玻璃钝化桥式整流器 GLASS PASSIVATED BRIDGE RECTIFIERS

FEATURES

- Plastic package has UL Flammability Classification 94V-0
- Glass passivated chip junctions
- High case dielectric strength of 1500 V_{RMS}
- High surge current capability
- High temperature soldering guaranteed
260°C/10 seconds, 0.375"(9.5mm) lead length

MECHANICAL DATA

- Case: molded plastic body
- Terminal: Plated leads solderable per MIL-STD-750 Method 2026
- Mounting position: Any (Note 4)
- Mounting Torque: 6 in – 1bs max.
- Weight: 0.15 ounce, 4.0 gram

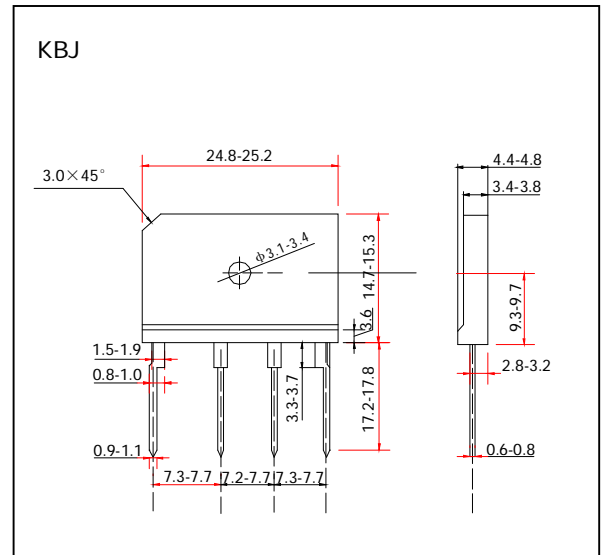

MAXIMUM RATINGS AND ELECTRICAL CHARACTERISTICS

- Ratings at 25°C ambient temperature unless otherwise specified
- Single Phase, half wave, 60Hz, resistive or inductive load
- For capacitive load derate current by 20%

	SYMBOLS	KBJ 4005G	KBJ 401G	KBJ 402G	KBJ 404G	KBJ 406G	KBJ 408G	KBJ 410G	UNIT	
Maximum Reverse Peak Repetitive Voltage	V _{RRM}	50	100	200	400	600	800	1000	Volts	
Maximum RMS Voltage	V _{RMS}	35	70	140	280	420	560	700	Volts	
Maximum DC Blocking Voltage	V _{DC}	50	100	200	400	600	800	100	Volts	
Maximum Average Forward Rectified Current, At T _c =100°C (Note 1) T _A =40°C (Note 2)	I _(AV)					4.0				Amps
Peak Forward Surge Current 8.3ms single half sine wave superimposed on rated load (JEDEC Method)	I _{FSM}					120				Amps
Rating for Fusing (t < 8.3ms)	I ² t					60				A ² s
Maximum Instantaneous Forward Voltage drop Per leg at 2.0A	V _F					1.0				Volts
Maximum DC Reverse Current at rated DC blocking voltage per element	T _A =25°C					5.0				μ A
	T _A =125°C					500				
Typical Junction Capacitance, per let (Note 3)	C _J	100.0				45.0			pF	
Typical Thermal Resistance (Note 1)	R _{JA}					22.0				°C/W
Operating Junction Temperature Range	T _J					(-55 to +150)			°C/W	
Storage Temperature Range	T _{STG}					(-55 to +150)			°C	

- Notes:**
1. Unit mounted on 1.6×1.6×0.06" thick (4.0×4.0×0.15cm) AL. plate
 2. Unit mounted on P.C.B. With 0.5×0.5"(1.2×1.2mm) copper pads and 0.375"(9.5mm) lead length
 3. Measured at 1.0 MHz and applied reverse voltage of 4.0 V
 4. Recommended mounting position is to bolt down on heatsink with silicone thermal compound for maximum Heat transfer with #6 screws

KBJ4005G THRU KBJ410G

RATINGS AND CHARACTERISTIC CURVES KBJ4005G THRU KBJ410G

