

Application

- 802.11 b/g/n AP/Router
- Dual Band Concurrent Router
- NAS
- iNIC

The RT3050 SOC combines Ralink's 802.11n draft compliant 1T1R MAC/BBP/RF, a high performance 320MHz MIPS24KEc CPU core, 5-port integrated 10/100 Ethernet switch/PHY, and an USB OTG. With the RT3050, there are very few external components required for 2.4GHz 11n wireless products. The RT3050 employs Ralink 2nd generation 11n technologies for longer range and better throughput. The embedded high performance CPU can process advanced applications effortlessly, such as routing, security and VOIP. The USB port can be configured to access external storage for Digital Home applications. In addition, the RT3050 has rich hardware interfaces (SPI/I2S/I2C/UART) to enable many possible applications.

- ◆ Support 16-bit SDR SDRAM (up-to 64M bytes)
- ◆ Support boot from 8/16-bit parallel NOR type Flash (up-to 16M bytes)
- ◆ Support boot from NAND type Flash (up-to 64 M bytes)
- ◆ Support boot from ROM iNIC mode
- ◆ USB2.0 OTG x 1
- ◆ Embedded a 5-port 10/100Mbps Ethernet switch and a 5-port UTP PHY
- ◆ Support 5 10/100 UTP ports
- ◆ Hardware NAT, QoS, TCP/UDP/IP Checksum offloading
- ◆ Slow speed I/O: GPIO, I2C, SPI, UART, JTAG, PCM and I2S

Features

- ◆ Embedded 1T1R 2.4G CMOS RF
- ◆ Embedded 802.11n 1T1R MAC/BBP w/MLD enhancement
- ◆ 150Mbps PHY data rate
- ◆ 20Mhz/40Mhz channel width
- ◆ Legacy and high throughput modes
- ◆ Reverse Data Grant (RDG) support
- ◆ Compressed Block ACK
- ◆ Up to 256 clients
- ◆ Multiple BSSID (up to 8)
- ◆ WEP64/128, WPA, WPA2 engines
- ◆ QOS - WMM, WMM Power Save
- ◆ Hardware frame aggregation
- ◆ International Regulation - 802.11h TPC
- ◆ MIPS 24KEc 320Mhz with 32KB I cache/16KB D cache

Order Information

Part Number	Temp Range	Package
RT3050F	-10~70 °C	Green/ RoHS Compliant TFBGA 289 balls (14mmx14mm)

Ralink Technology, Corp. (Taiwan)
 5th F. No. 36, Taiyuan St, Jhubei City, Hsin-Chu, Taiwan, R.O.C.
 Tel: 886-3-560-0868 Fax: 886-3-560-0818

Ralink Technology, Corp. (USA)
 20833 Stevens Creek Blvd., Suite 200 Cupertino, CA95014
 Tel: (408) 725-8070 Fax: (408)725-8069
<http://www.ralinktech.com>

Functional Block Diagram

Table of Content

1. Pin Description.....	6
1.1 BGA Package Diagram	6
1.2 Pin Description	7
1.3 Pins Sharing Scheme.....	11
1.4 Boot strapping Signal description.....	12
2 Maximum Ratings and Operating Conditions	13
2.1 Absolute Maximum Ratings.....	13
2.2 Thermal Information	13
2.3 Operating Conditions.....	13
2.4 Storage Condition.....	13
2.5 DC Electrical Characteristics	13
2.5.1 DC characteristics for GPIO pins with 4mA driving capability.....	13
2.5.2 DC characteristics for GPIO pins with 8mA driving capability.....	14
2.6 AC Electrical Characteristics	14
2.6.1 SDRAM Interface.....	14
2.6.2 Flash/SRAM Interface	15
2.6.3 Power On Sequence.....	17
2. Function Description	17
3.1 Overview.....	17
3.2 Memory Map Summary.....	18
3.3 MIPS 24KEc Processor	19
3.3.1 Features	19
3.3.2 Block Diagram	21
3.4 System Control	22
3.4.1 Features	22
3.4.2 Block Diagram	22
3.4.3 Register Description (base: 0x1000.0000)	22
3.5 Timer.....	26
3.5.1 Features	26
3.5.2 Block Diagram	27
3.5.3 Register Description (base: 0x1000.0100)	27
3.6 Interrupt Controller.....	29
3.6.1 Features	29
3.6.2 Block Diagram	30
3.6.3 Register Description (base: 0x1000.0200)	30
3.7 UART.....	33
3.7.1 Features	33
3.7.2 Loop-back control for communications link fault isolation Block Diagram	34
3.7.3 Register Description (base: 0x1000.0500)	34
3.8 UART Lite	40
3.8.1 Features	40
3.8.2 Block Diagram	40
3.8.3 Register Description (base: 0x1000.0C00)	40
3.9 Programmable I/O.....	45

3.9.1 Features	45
3.9.2 Block Diagram	45
3.9.3 Register Description (base: 0x1000.0600)	45
3.10 I2C Controller.....	52
3.10.1 Features	52
3.10.2 Block Diagram	52
3.10.3 Register Description (base: 0x1000.0900)	52
3.11 SPI Controller.....	56
3.11.1 Features	56
3.11.2 Block Diagram	56
3.11.3 Register Description (base: 0x1000.0B00)	56
3.12 Generic DMA Controller.....	59
3.12.1 Features	59
3.12.2 Block Diagram	59
3.12.3 Register Description (base: 0x10000700)	59
3.13 PCM Controller.....	62
3.13.1 Features	62
3.13.2 Block Diagram	62
3.13.3 Register Description (base: 0x1000.0400)	63
3.14 I2S Controller.....	67
3.14.1 Features	67
3.14.2 Block Diagram	67
3.14.3 Register Description (base: 0x1000.0A00)	68
3.15 Memory Controller.....	70
3.15.1 Features	70
3.15.2 Block Diagram	70
3.15.3 Register Description (base: 0x1000.0300)	70
3.16 NAND Flash Controller.....	74
3.16.1 Features	74
3.16.2 Block Diagram	74
3.16.3 Register Description (base: 0x1000.0800)	74
3.17 Frame Engine.....	77
3.17.1 Features	77
3.17.2 Block Diagram	78
3.17.3 Register Description (base: 0x1010.0000)	81
3.18 Ethernet Switch	96
3.18.1 Features	96
3.18.2 Block Diagram	97
3.18.3 Register Description (base: 0x1011.0000)	98
3.18.4 MII control register	110
3.18.5 Flow control settings.....	113
3.19 USB OTG Controller & PHY	116
3.19.1 Features	116
3.19.2 Block Diagram	117
3.19.3 Register Description (base: 0x101C.0000)	117

3.20 802.11n 1T1R MAC/BBP	165
3.20.1 Features	165
3.20.2 Block Diagram	165
3.20.3 Register Description (base: 0x1018.0000)	166
4. Package Physical Dimension.....	212
4.1 TFBGA 289B (14×14×1.4mm)	212
5. Revision History.....	214

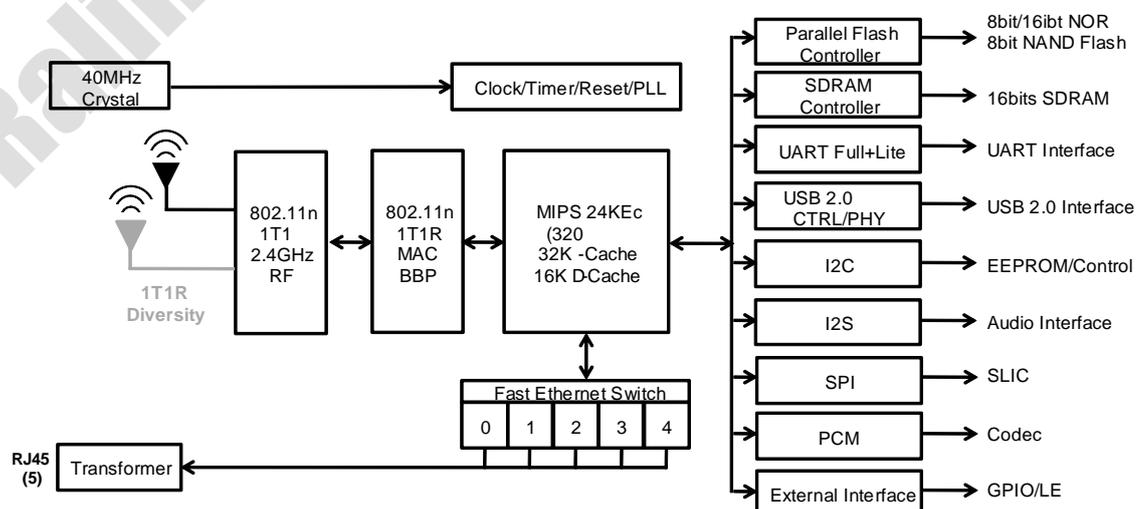
Ralink Confidential for ASEC

Table of Figures

Fig. 2-5-1 SDRAM Interface.....	15
Fig. 2-5-2 Flash/SRAM Interface.....	16
Fig. 2-5-4 Power ON Sequence	17
Fig. 3-1-1 RT3050 Block Diagram	18
Fig. 3-3-1 MIPS 24KEc Processor Diagram	21
Fig. 3-5-1 Timer Block Diagram	27
Fig. 3-6-1 Interrupt Controller Block Diagram	30
Fig. 3-7-1 UART Block Diagram	34
Fig. 3-8-1 UART Lite Block Diagram.....	40
Fig. 3-9-1 Program I/O Block Diagram.....	45
Fig. 3-10-1 I2C controller Block Diagram	52
Fig. 3-11-1 SPI controller Block Diagram	56
Fig. 3-12-1 Generic DMA controller Block Diagram	59
Fig. 3-13-1 PCM Controller Block Diagram	62
Fig. 3-14-1 I2S Transmitter Block Diagram	67
Fig. 3-14-2 I2S Transmitter	67
Fig. 3-15-1 Flash/SRAM/SDRAM controller Block Diagram	70
Fig. 3-15-2 Flash/SRAM/SDRAM Controller R/W waveform	72
Fig. 3-16-1 NAND Flash Controller Block Diagram	74
Fig. 3-17-1 Frame Engine Block Diagram.....	78
Fig. 3-17-2 PDMA FIFO-like Ring Concept.....	79
Fig. 3-17-3 PDMA TX Descriptor Format.....	80
Fig. 3-17-4 PDMA RX Descriptor Format	81
Fig. 3-18-1 Ethernet Switch Block Diagram	97
Fig. 3-18-2 Double Tag.....	114
Fig. 3-18-3 Special Tag.....	114
Fig. 3-18-4 Packet Classification, QoS, Scheduling and Buffer control.....	115
Fig. 3-19-1 USB OTG Controller & PHY Block Diagram	117
Fig. 3-20-1 802.11n 1T1R MAC/BBP Block Diagram.....	165
Fig. 3-20-2 802.11n 1T1R MAC/BBP Register Map	166
Fig. 3-20-3 TX frame Information.....	203
Fig. 3-20-4 TX Descriptor Format	204
Fig. 3-20-5 TXWI Format.....	204
Fig. 3-20-6 RX Descriptor Ring.....	206
Fig. 3-20-7 RX Descriptor Format.....	206
Fig. 3-20-8 RXWI Format.....	207

1. Pin Description
1.1 BGA Package Diagram

Top view (left portion)

	1	2	3	4	5	6	7	8	9
A	RFO_V12A	RFO_2G_OUTP	RFO_2G_INN	RFO_2G_INP	PLL_VC_CAP	BG_RES_12K	LDORF_OUT_V12	RF_BB2_V12A	ADC_VREFN
B	NC	GND	RF_BB1_V12A	VCO_VCO_V12A	PLL_DIV_V12A	LDOPLL_OUT_V12	LDORF_IN_VX	RFO_TSSI_IN	ADC_V12A
C	NC	RF1_V12A	GND	VCO_LO_V12A	PLL_PRE_V12A	PLL_X1	PLL_X2	BASE_TRX_IP	BASE_TRX_QN
D	NC	RFO_PA_PE	RFO_LO_V12A	GND	GND	BG_V33A	NC	BASE_TRX_IN	BASE_TRX_QP
E	NC	RF_V33A	NC	GND	GND	GND	GND	GND	GND
F	DSR_N	TXD	ANT_TRN	WLAN_LED_N	GND	GND	GND	GND	GND
G	CTS_N	RTS_N	TXD2	ANT_TRNB	GND	GND	GND	GND	GND
H	UPHY_VDDA_V33A	UPHY_VRES	DCD_N	RXD2	SOC_CO_V12D	GND	GND	GND	GND
J	UPHY_PADP	UPHY_PADM	RXD	DTR_N	SOC_IO_V33D	GND	GND	GND	GND
K	NC	NC	UPHY_VBUS	RIN	GND	GND	GND	GND	GND
L	NC	NC	UPHY_ID	UPHY_VDDL_V12D	SOC_CO_V12D	GND	GND	GND	GND
M	NC	NC	NC	SOC_CO_V12D	NC	SOC_IO_V33D	SOC_IO_V33D	GND	GND
N	NC	NC	NC	SOC_IO_V33D	SOC_IO_V33D	EPHY_V33A	EPHY_V33A	EPHY_V33A	EPHY_V33A
P	NC	NC	NC	EPHY_REF_RES	EPHY_LED3_N	EPHY_LED4_N	EPHY_LED0_N	EPHY_V33A	EPHY_V33A
R	EPHY_RXN_p0	EPHY_RXP_p0	EPHY_TXP_p1	EPHY_TXN_p1	EPHY_TXP_p3	EPHY_TXN_p3	EPHY_LED1_N	EPHY_LED2_N	SPI_DIN
T	EPHY_TXN_p0	EPHY_RXP_p1	EPHY_RXN_p2	EPHY_TXN_p2	EPHY_RXP_p3	EPHY_RXN_p4	EPHY_TXN_p4	PORST_N	SPI_CLK
U	EPHY_TXP_p0	EPHY_RXN_p1	EPHY_RXP_p2	EPHY_TXP_p2	EPHY_RXN_p3	EPHY_RXP_p4	EPHY_TXP_p4	SPI_DOUT	SPI_EN

Top view (right portion)

	10	11	12	13	14	15	16	17
A	ADC_VREFP	ADC_VREF025P	ADC_VREF	LDODIG_OUT_V12	SRAM_CS_N	MA20	MD1	MD6
B	ADC_V12D	ADC_VREF025N	NC	OE_N	FLASH_CS_N	MD0	MD5	MD4
C	RFO_LNA_PE	LDOADC_IN_VX	LDODIG_IN_VX	WE_N	MA21	MD3	MD8	MD9
D	GND	LDOADC_OUT_V12	LDO_V33A	MA22	SOC_CO_V12D	MD2	MD10	MD13
E	GND	GND	GND	SOC_IO_V33D	SOC_CO_V12D	MD7	MD14	MD15
F	GND	GND	GND	GND	SOC_CO_V12D	MD11	MA3	MA2
G	GND	GND	GND	GND	SOC_CO_V12D	MD12	MA1	BPPLL_VDD_V12D
H	GND	GND	GND	GND	SOC_IO_V33D	MA4	MA0	BPPLL_POC_V33D
J	GND	GND	GND	GND	SOC_IO_V33D	BPPLL_DVDD_V12D	BPPLL_DVDDA_V12D	BPPLL_AVDD_V12A
K	GND	GND	GND	GND	SOC_IO_V33D	MA5	MA7	MA6
L	GND	GND	GND	GND	SOC_IO_V33D	SOC_CO_V12D	MA9	MA8
M	GND	GND	GND	SOC_IO_V33D	SOC_IO_V33D	MA15	MA11	MA10
N	SOC_IO_V33D	SOC_IO_V33D	SOC_IO_V33D	SOC_IO_V33D	NC	MA19	MA13	MA14
P	SOC_CO_V12D	SOC_CO_V12D	NC	NC	NC	NC	MA18	MA12
R	I2C_SCLK	JTAG_TDO	NC	NC	NC	NC	SDRAM_CLK	MA17
T	I2C_SD	JTAG_TDI	JTAG_TRST_N	NC	NC	NC	SDRAM_RAS_N	MA16
U	GPIO0	JTAG_TMS	JTAG_TCLK	NC	NC	NC	NC	SDRAM_CS_N

1.2 Pin Description

Name	Drive (mA)	I/O/ IPU/IPD	Description
JTAG interfaces:			
JTAG_TRST_N	4	I/O, IPU	JTAG TRST. Shared with GPIOs.
JTAG_TCLK	4	I/O, IPD	JTAG TCLK. Shared with GPIOs.
JTAG_TMS	4	I/O, IPD	JTAG TMS. Shared with GPIOs.
JTAG_TDI	4	I/O, IPD	JTAG TDI. Shared with GPIOs.
JTAG_TDO	4	I/O, IPD	JTAG TDO. Shared with GPIOs.
UART Lite interface:			
RXD2	4	I/O, IPD	UART Lite RXD. Shared with GPIOs.
TXD2	4	I/O, IPD	UART Lite TXD. Shared with GPIOs.
UART Full interface:			
RXD	4	I/O, IPD	UART RXD. Shared with GPIOs.
RIN	4	I/O, IPD	UART RIN. Shared with GPIOs.
CTS_N	4	I/O, IPD	UART CTS_N. Shared with GPIOs.
DSR_N	4	I/O, IPD	UART DSR_N. Shared with GPIOs.
DCD_N	4	I/O, IPD	UART DCD_N. Shared with GPIOs.
TXD	4	I/O, IPD	UART TXD. Shared with GPIOs.
DTR_N	4	I/O, IPD	UART DTR. Shared with GPIOs.
RTS_N	4	I/O, IPD	UART RTS. Shared with GPIOs.
SPI interface:			
SPI_DIN	4	I/O, IPD	SPI DIN. Shared with GPIOs.
SPI_DOUT	4	I/O, IPD	SPI DOUT. Shared with GPIOs.
SPI_CLK	4	I/O, IPD	SPI Clock. Shared with GPIOs.
SPI_EN	4	I/O, IPD	SPI Data Enable. Shared with GPIOs.
I2C interface:			
I2C_SCLK	8	I/O, IPU	I2C Clock. Shared with GPIOs.
I2C_SD	8	I/O, IPU	I2C Data. Shared with GPIOs.
GPIO interface:			
GPIO0	4	I/O, IPD	When NAND-flash is applied, this pin should be used as the BUSY/READY pin. Otherwise, it is dedicated as the GPIO0 Pin
Misc signals:			
PORST_N	2	I, IPU	Power on reset
WLAN_LED_N	4	O	WLAN Activity LED
ANT_TRN	8	O	Positive signal for antenna T/R switch
ANT_TRNB	8	O	Negative signal for antenna T/R switch
5-Port PHY:			
EPHY_REF_RES		I/O	Connect to an external resistor to provide accurate bias current
EPHY_RXN_P0		I	10/100 PHY Port #0 RXN
EPHY_RXP_P0		I	10/100 PHY Port #0 RXP
EPHY_TXN_P0		O	10/100 PHY Port #0 TXN
EPHY_TXP_P0		O	10/100 PHY Port #0 TXP
EPHY_RXN_P1		I	10/100 PHY Port #1 RXN
EPHY_RXP_P1		I	10/100 PHY Port #1 RXP
EPHY_TXN_P1		O	10/100 PHY Port #1 TXN
EPHY_TXP_P1		O	10/100 PHY Port #1 TXP
EPHY_RXN_P2		I	10/100 PHY Port #2 RXN
EPHY_RXP_P2		I	10/100 PHY Port #2 RXP
EPHY_TXN_P2		O	10/100 PHY Port #2 TXN
EPHY_TXP_P2		O	10/100 PHY Port #2 TXP
EPHY_RXN_P3		I	10/100 PHY Port #3 RXN
EPHY_RXP_P3		I	10/100 PHY Port #3 RXP

Name	Drive (mA)	I/O/ IPU/IPD	Description
EPHY_TXN_P3		O	10/100 PHY Port #3 TXN
EPHY_TXP_P3		O	10/100 PHY Port #3 TXP
EPHY_RXN_P4		I	10/100 PHY Port #4 RXN
EPHY_RXP_P4		I	10/100 PHY Port #4 RXP
EPHY_TXN_P4		O	10/100 PHY Port #4 TXN
EPHY_TXP_P4		O	10/100 PHY Port #4 TXP
EPHY_LED0_N	4	O	10/100 PHY Port #0 activity LED
EPHY_LED1_N	4	O	10/100 PHY Port #1 activity LED
EPHY_LED2_N	4	O	10/100 PHY Port #2 activity LED
EPHY_LED3_N	4	O	10/100 PHY Port #3 activity LED
EPHY_LED4_N	4	O	10/100 PHY Port #4 activity LED
USB OTG PHY interface:			
UPHY_VRES		I/O	Connect to an external 8.2K Ohm resistor for band-gap reference circuit
UPHY_VBUS		I/O	USB OTG VBUS pin; Connect to the VBUS pin of the USB connector
UPHY_PADM		I/O	USB OTG data pin Data-
UPHY_PADP		I/O	USB OTG data pin Data+
UPHY_ID		I/O	USB OTG ID pin. Connect to ID pin on the Mini-type connect
SDRAM/Flash/SRAM Interface: (MD16 ~ MD31 are shared with GPIOs)			
MD31	8	I/O, IPD	SDRAM/Flash/SRAM Data bit #31 for RT3050LF
MD30	8	I/O, IPD	SDRAM/Flash/SRAM Data bit #30 for RT3050LF
MD29	8	I/O, IPD	SDRAM/Flash/SRAM Data bit #29 for RT3050LF
MD28	8	I/O, IPD	SDRAM/Flash/SRAM Data bit #28 for RT3050LF
MD27	8	I/O, IPD	SDRAM/Flash/SRAM Data bit #27 for RT3050LF
MD26	8	I/O, IPD	SDRAM/Flash/SRAM Data bit #26 for RT3050LF
MD25	8	I/O, IPD	SDRAM/Flash/SRAM Data bit #25 for RT3050LF
MD24	8	I/O, IPD	SDRAM/Flash/SRAM Data bit #24 for RT3050LF
MD23	8	I/O, IPD	SDRAM/Flash/SRAM Data bit #23 for RT3050LF
MD22	8	I/O, IPD	SDRAM/Flash/SRAM Data bit #22 for RT3050LF
MD21	8	I/O, IPD	SDRAM/Flash/SRAM Data bit #21 for RT3050LF
MD20	8	I/O, IPD	SDRAM/Flash/SRAM Data bit #20 for RT3050LF
MD19	8	I/O, IPD	SDRAM/Flash/SRAM Data bit #19 for RT3050LF
MD18	8	I/O, IPD	SDRAM/Flash/SRAM Data bit #18 for RT3050LF
MD17	8	I/O, IPD	SDRAM/Flash/SRAM Data bit #17 for RT3050LF
MD16	8	I/O, IPD	SDRAM/Flash/SRAM Data bit #16 for RT3050LF
MD15	8	I/O, IPD	SDRAM/Flash/SRAM Data bit #15
MD14	8	I/O, IPD	SDRAM/Flash/SRAM Data bit #14
MD13	8	I/O, IPD	SDRAM/Flash/SRAM Data bit #13
MD12	8	I/O, IPD	SDRAM/Flash/SRAM Data bit #12
MD11	8	I/O, IPD	SDRAM/Flash/SRAM Data bit #11
MD10	8	I/O, IPD	SDRAM/Flash/SRAM Data bit #10
MD9	8	I/O, IPD	SDRAM/Flash/SRAM Data bit #9
MD8	8	I/O, IPD	SDRAM/Flash/SRAM Data bit #8
MD7	8	I/O, IPD	SDRAM/NAND or NOR Flash/SRAM Data bit #7
MD6	8	I/O, IPD	SDRAM/NAND or NOR Flash/SRAM Data bit #6
MD5	8	I/O, IPD	SDRAM/NAND or NOR Flash/SRAM Data bit #5
MD4	8	I/O, IPD	SDRAM/NAND or NOR Flash/SRAM Data bit #4
MD3	8	I/O, IPD	SDRAM/NAND or NOR Flash/SRAM Data bit #3
MD2	8	I/O, IPD	SDRAM/NAND or NOR Flash/SRAM Data bit #2
MD1	8	I/O, IPD	SDRAM/NAND or NOR Flash/SRAM Data bit #1
MD0	8	I/O, IPD	SDRAM/NAND or NOR Flash/SRAM Data bit #0

Name	Drive (mA)	I/O/ IPU/IPD	Description
MA22	8	O	Flash/SRAM Address bit #22 This pin is shared with NAND flash CLE
MA21	8	O	Flash/SRAM Address bit #21 This pin is shared with NAND flash RE_N
MA20	8	O, IPD	Flash/SRAM Address bit #20 This pin is shared with NAND flash WE_N
MA19	8	O, IPD	Flash/SRAM Address bit #19 or SDRAM DQM bit#3
MA18	8	O, IPD	Flash/SRAM Address bit #18 or SDRAM DQM bit#2
MA17	8	O, IPD	Flash/SRAM Address bit #17 or SDRAM DQM bit#1
MA16	8	O, IPD	Flash/SRAM Address bit #16 or SDRAM DQM bit#0
MA15	8	O, IPD	Flash/SRAM Address bit #15 or SDRAM BA bit#1
MA14	8	O, IPD	Flash/SRAM Address bit #14 or SDRAM BA bit#0
MA13	8	O, IPD	SDRAM/Flash/SRAM Address bit #13 This pin is shared with NAND flash ALE
MA12	8	O, IPD	SDRAM/Flash/SRAM Address bit #12
MA11	8	O, IPD	SDRAM/Flash/SRAM Address bit #11
MA10	8	O, IPH	SDRAM/Flash/SRAM Address bit #10
MA9	8	O, IPD	SDRAM/Flash/SRAM Address bit #9
MA8	8	O, IPD	SDRAM/Flash/SRAM Address bit #8
MA7	8	O, IPD	SDRAM/Flash/SRAM Address bit #7
MA6	8	O, IPD	SDRAM/Flash/SRAM Address bit #6
MA5	8	O, IPD	SDRAM/Flash/SRAM Address bit #5
MA4	8	O, IPD	SDRAM/Flash/SRAM Address bit #4
MA3	8	O, IPD	SDRAM/Flash/SRAM Address bit #3
MA2	8	O, IPD	SDRAM/Flash/SRAM Address bit #2
MA1	8	O, IPD	SDRAM/Flash/SRAM Address bit #1
MA0	8	O, IPD	SDRAM/Flash/SRAM Address bit #0
SDRAM_RAS_N	8	O	SDRAM Row Address Select
SDRAM_CS_N	8	O	SDRAM Chip Select
SDRAM_CLK	8	O	SDRAM Clock
WE_N	8	O	Flash/SRAM Write Enable and SDRAM Write Enable (SDRAM_WE_N)
OE_N	8	O	Flash/SRAM Write Output Enable and SDRAM Column Address Select (SDRAM_CAS_N)
FLASH_CS_N	8	O	Flash Chip Select or NAND Flash CS_N if boot from NAND is selected.
SRAM_CS_N	8	O	SRAM Chip Select
RF interface, related LDO and power pins:			
RFO_2G_INP		I	2.4GHz RX0 input (positive)
RFO_2G_INN		I	2.4GHz RX0 input (negative)
RFO_2G_OUTP		O	2.4GHz TX0 output (positive)
RFO_PA_PE		O	0 ~ 3.3V control for external PA0 (20mA)
RFO_LNA_PE		O	External LNA0 3.3V power (50mA)
RFO_TSSI_IN		I	TX signal strength monitor input0 (0~3.3V)
RF_BB1_V12A		P	1.2V Supply for analog baseband
RF_BB2_V12A		P	1.2V Supply for analog baseband
RFO_LO_V12A		P	1.2V Supply for LO & IF
RFO_V12A		P	1.2V Supply for RF channel 0
RF1_V12A		P	1.2V Supply for RF channel 1
RF_V33A		P	3.3V supply for PA Enable drivers (40mA)
VCO_VCO_V12A		P	1.2V Supply for VCO core
PLL_VC_CAP		I/O	PLL external loop filter

Name	Drive (mA)	I/O/ IPU/IPD	Description
ADC_V12D		P	1.2V supply for ADC digital logics
ADC_VREF		I/O	Main ADC reference voltage
ADC_VREF025P		I/O	Auxiliary ADC reference voltage (p) for RT3050F
ADC_VREF025N		I/O	Auxiliary ADC reference voltage (n) for RT3050F
ADC_V12A		P	1.2V supply for ADC analog blocks for RT3050F
ADC_VREFP		O	Auxiliary ADC reference voltage (p) for RT3050F
ADC_VREFN		O	Auxiliary ADC reference voltage (n) for RT3050F
BASE_TRX_QN		I/O	Baseband Q 20Mhz debug I/O (negative) for RT3050F
BASE_TRX_QP		I/O	Baseband Q 20Mhz debug I/O (positive) for RT3050F
BASE_TRX_IN		I/O	Baseband I 20Mhz debug I/O (negative)
BASE_TRX_IP		I/O	Baseband I 20Mhz debug I/O (positive)
LDODIG_IN_VX		I	LDO 1.5-2.0V input
LDO_V33A		P	3.3V supply for LDOs
LDODIG_OUT_V12		O	LDO 1.2V output for digital core
LDOADC_IN_VX		I	LDO 1.5-2V input for ADC
LDOADC_OUT_V12		O	LDO 1.2V output for ADC
LDORF_IN_VX		I	LDO 1.5~2V input for RF core and PLL
LDORF_OUT_V12		O	LDO 1.2V output for RF core
LDOPLL_OUT_V12		O	LDO 1.2V output for RF PLL
BG_RES_12K		I/O	External reference resistor (12K ohm)
BG_V33A		P	3.3V supply for band gap reference
PLL_X1		I	Crystal oscillator input
PLL_X2		O	Crystal oscillator output
PLL_V12A		P	1.2V Supply of PLL for RT3050LF
PLL_DIV_V12A		P	1.2V Supply for PLL divider for RT3050F
PLL_PRE_V12A		P	1.2V Supply for PLL prescaler for RT3050F
VCO_LO_V12A		P	1.2V Supply for VCO output buffer
Other power pins:			
BPLL_DVDD_V12D		P	1.2v PLL digital power supply
BPLL_DVDDA_V12D		P	1.2v PLL digital power supply for RT3050F
BPLL_AVDD_V12A		P	1.2v PLL analog power supply
BPLL_POC_V33D		P	3.3v PLL digital power supply for RT3050F
BPLL_VDD_V12D		P	1.2v PLL digital power supply for RT3050F
EPHY_V33A		P	3.3v 10/100 PHY analog power supply
UPHY_VDDA_V33A		P	3.3v USB PHY analog power supply
UPHY_VDDL_V12D		P	1.2v USB PHY digital power supply
SOC_IO_V33D		P	3.3v digital I/O power supply
SOC_CO_V12D		P	1.2v digital core power supply
Ground pins:			
GND		P	Ground pin

Note:

1. IPD means internal pull-down; IPU means internal pull-up; P means power.

1.3 Pins Sharing Scheme

Some pins are shared with GPIO to provide maximum flexibility for system designers. The RT3050 provides up to 22 GPIO pins. Users can configure SYSCFG and GPIOMODE registers in the System Control block to specify the pin function. Unless stated otherwise, all the GPIO pins are in input mode after reset.

JTAG_GPIO_MODE description

Pin Name	JTAG_GPIO_MODE=0	JTAG_GPIO_MODE=1
JTAG_TRST_N	JTAG_TRST_N	GPIO21
JTAG_TCLK	JTAG_TCLK	GPIO20
JTAG_TMS	JTAG_TMS	GPIO19
JTAG_TDI	JTAG_TDI	GPIO18
JTAG_TDO	JTAG_TDO	GPIO17

UARTL_GPIO_MODE description

Pin Name	UARTL_GPIO_MODE=0	UARTL_GPIO_MODE=1
RXD2	RXD2	GPIO16
TXD2	TXD2	GPIO15

UARTF_SHARE_MODE description

Pin Name	3'b000 UARTF	3'b001 PCM, UARTF	3'b010 PCM, I2S	3'b011 I2S UARTF	3'b100 PCM, GPIO	3'b101 GPIO, UARTF	3'b110 GPIO I2S	3'b111 GPIO
RIN	RIN	PCMDTX	PCMDTX	RXD	PCMDTX	GPIO14	GPIO14	GPIO14
DSR_N	DSR_N	PCMDRX	PCMDRX	CTS_N	PCMDRX	GPIO13	GPIO13	GPIO13
DCD_N	DCD_N	PCMCLK	PCMCLK	TXD	PCMCLK	GPIO12	GPIO12	GPIO12
DTR_N	DTR_N	PCMFS	PCMFS	RTS_N	PCMFS	GPIO11	GPIO11	GPIO11
RXD	RXD	RXD	REFCLK	REFCLK	REFCLK	RXD	REFCLK	GPIO10
CTS_N	CTS_N	CTS_N	I2SSD	I2SSD	GPIO9	CTS_N	I2SSD	GPIO9
TXD	TXD	TXD	I2SWS	I2SWS	GPIO8	TXD	I2SWS	GPIO8
RTS_N	RTS_N	RTS_N	I2SCLK	I2SCLK	GPIO7	RTS_N	I2SCLK	GPIO7

SPI_GPIO_MODE description

Pin Name	SPI_GPIO_MODE=0	SPI_GPIO_MODE=1
SPI_DIN	SPI_DIN	GPIO6
SPI_DOUT	SPI_DOUT	GPIO5
SPI_CLK	SPI_CLK	GPIO4
SPI_EN	SPI_EN	GPIO3

I2C_GPIO_MODE description

Pin Name	I2C_gpio_mode=0	I2C_gpio_mode=1
I2C_SCLK	I2C_SCLK	GPIO2
I2C_SD	I2C_SD	GPIO1

Notes:

1. The default direction for GPIO pins are input (i.e. tri-state) except the GPIO pins shared with the JTAG interface (GPIO17...GPIO21). The default value for JTAG_GPIO_MODE is 1.
2. Please refer to the "Pin Description" section for the driving capability of each GPIO.
3. Please refer to the "DC characteristics" section for more detailed DC characteristics.

1.4 Boot strapping Signal description

Pin Name	Boot Strapping Signal Name	Description
MA7..MA0	TEST_CODE[7:0]	A vector to set CHIP operation/testing modes. In normal operation, please use the default value: 8'b00000000
{MA9, MA8}	BOOT_FROM	2'b00: boot from external 16-bit flash (default) 2'b01: boot from external 8-bit flash 2'b10: boot from external NAND flash 2'b11: boot from internal ROM
MA10	CPU_CLK_SEL	1'b0: 320Mhz(please add a pull down resistor here) 1'b1: Reserved
MA12	BIG_ENDIAN	0: Little Endian (default) 1: Big Endian
MA13	BYPASS_PLL	0: Do Not Bypass PLL (default) 1: Bypass PLL
MA14	BOOT_ADDR	0: CPU boots at address 0x1FC00000(default) 1: CPU boots at address 0x1F000000
{MA17:MA16}	INC_SEL	2'b00: PHY-TO-PHY INIC(default) 2'b01: Reserved 2'b10: USB INIC 2'b11: Reserved
MA20	INIC_8MB_SDRAM	For iNIC Mode, MA20 determines the SDRAM size as follows: 0: INIC SDRAM size is 2MB (default) 1: INIC SDRAM size is 8MB
MA21	INIC_EE_SDRAM	0: Take INIC SDRAM size from INIC_8MB_SDRAM setting 1: Take INIC SDRAM size from EEPROM

2 Maximum Ratings and Operating Conditions Absolute Maximum Ratings

Supply Voltage	3.6V
Vcc to Vcc Decouple.....	-0.3 to +0.3V
Input, Output or I/O Voltage.....	GND -0.3V to Vcc+0.3V

2.2 Thermal Information

Maximum Junction Temperature (Plastic Package)	125°C
Maximum Lead Temperature (Soldering 10s).....	260°C

Thermal characteristics in still air condition

Thermal Resistance θ_{JA} (°C/W) for JEDEC 2L system PCB	60.5°C/W
Thermal Resistance θ_{JA} (°C/W) for JEDEC 4L system PCB	26.0°C/W
Thermal Resistance θ_{JC} (°C/W) for JEDEC 2L system PCB	7.9°C/W
Thermal Resistance θ_{JC} (°C/W) for JEDEC 4L system PCB	6.9°C/W
Thermal Characterization parameter Ψ_{jt} (°C/W) for JEDEC 2L system PCB	2.3°C/W
Thermal Characterization parameter Ψ_{jt} (°C/W) for JEDEC 4L system PCB	1.6°C/W

Note: JEDEC 51-9 system FR4 PCB size: 101.5x114.5mm (4"x4.5")

2.3 Operating Conditions

Operational Ambient Range.....	-10 to 70°C
Core Supply Voltage.....	1.2V +/- 5%
I/O Supply Voltage	3.3V +/- 10%
USB PVBUS Voltage	5V +/- 10%

*Note: The external heat sink of the IC product and/or forced air flow environment is required

2.4 Storage Condition

The calculated shelf life is 12 months if stored in a sealed bag between 0°C and 40°C at less than 90% relative humidity (RH). After the bag is opened, devices that are subjected to solder reflow or other high temperature processes must be handled in the following manner:

- Mounted within 168-hours of factory conditions < 30°C /60% RH
- Storage humidity needs to be maintained at <10% RH
- Baking is necessary if the customer exposes the component to air for over 168 hrs, baking condition:
125°C / 8hrs

2.5 DC Electrical Characteristics

Parameters	Sym	Conditions	Min	Type	Max	Unit
3.3V Supply Voltage	Vcc33		3.0	3.3	3.6	V
1.5V Supply Voltage	Vcc15		1.14	1.2	1.26	V
3.3V Current Consumption	Icc33			205mA		mA
1.5V Current Consumption	Icc15			470mA		mA
2.0V Current Consumption (@transformer center tap)	Icc20			514 mA		mA

2.5.1 DC characteristics for GPIO pins with 4mA driving capability

Symbol	Min	Normal	Max
--------	-----	--------	-----

VIH	2.0v		5.5v
VIL	-0.3v		0.8v
VOH	2.4v		
VOL			0.4v
IOH	10.0mA	19.4mA	32.1mA
IOL	6.5mA	10.4mA	14.4mA

2.5.2 DC characteristics for GPIO pins with 8mA driving capability

Symbol	Min	Normal	Max
VIH	2.0v		5.5v
VIL	-0.3v		0.8v
VOH	2.4v		
VOL			0.4v
IOH	14.0mA	27.2mA	44.9mA
IOL	9.8mA	15.7mA	21.8mA

Ralink Confidential for SEC

2.6 AC Electrical Characteristics

2.6.1 SDRAM Interface

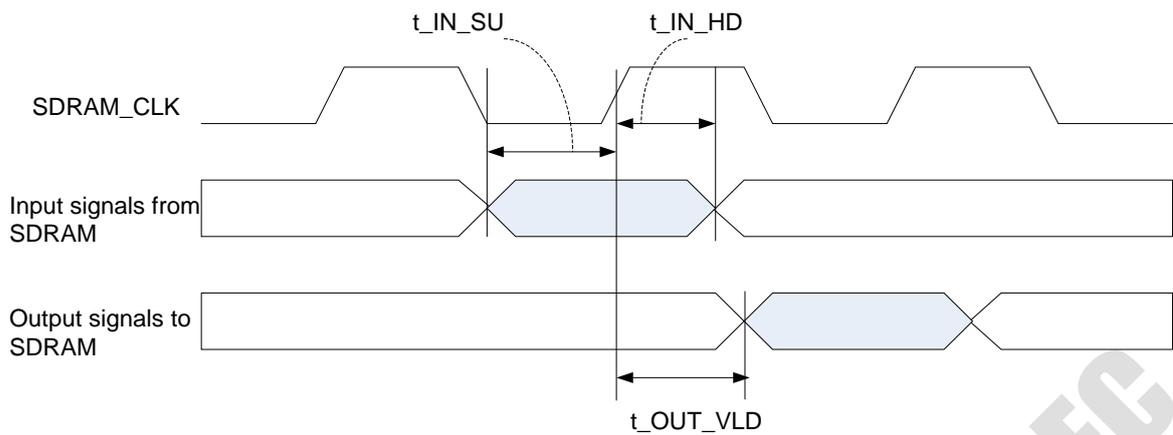
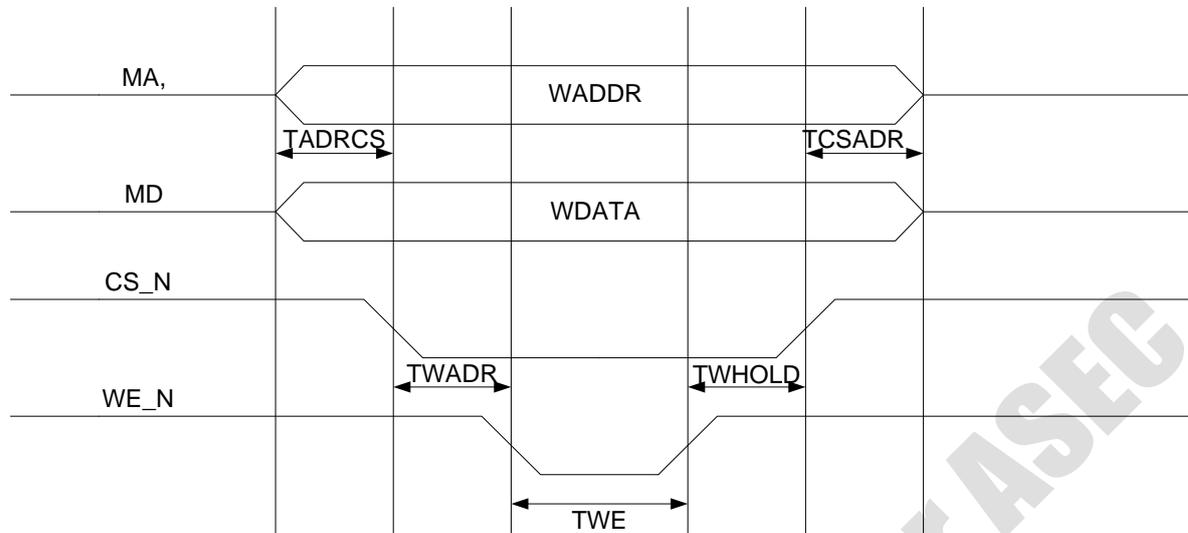

Fig. 2-5-1 SDRAM Interface

Symbol	Description	Min	Max	Unit	Remark
t_{IN_SU}	Setup time for Input signals (e.g. MD*)	1.5	-	ns	
t_{IN_HD}	Hold time for input signals	1.5	-	ns	
t_{OUT_VLD}	SDRAM_CLK to output signals (MA*, MD*, SDRAM_RAS_N,...) valid	1.5	6	ns	output load: SDRMA_CLK: 2.5pF Addr/Ctrl: 2.5pF Data: 4.0pF

2.6.2 Flash/SRAM Interface

Flash, Async. SRAM Write Timing



Flash, Async. SRAM Read Timing

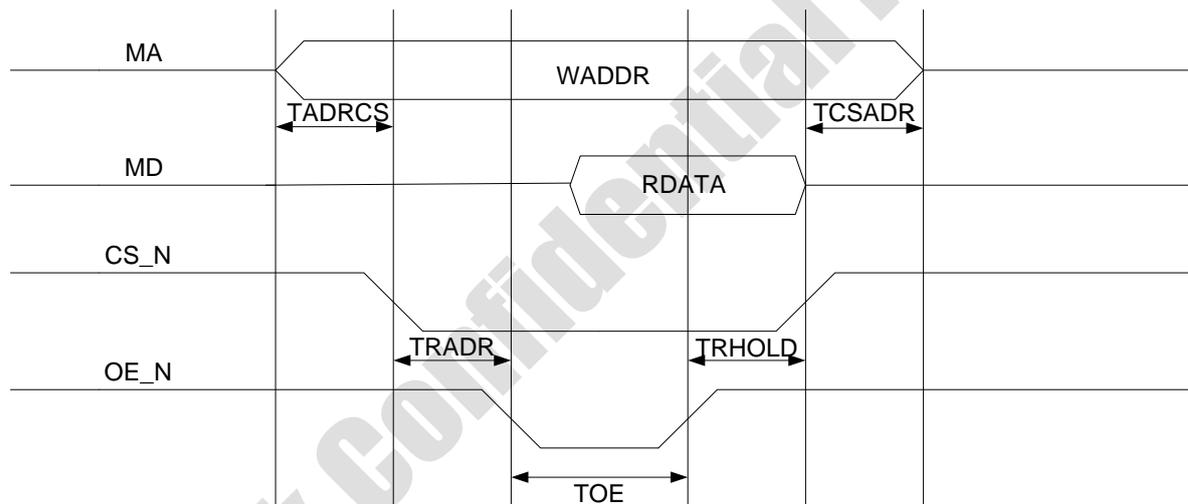

Fig. 2-5-2 Flash/SRAM Interface

Please refer to the "Memory Controller" section for more information about the timing setting on the Flash/SRAM interface.

2.6.3 Power On Sequence

Fig. 2-5-4 Power ON Sequence

Symbol	Description	Min	Max	Unit	Remark
t_{CO_IO}	Time between core power on to I/O power on	0	-	ms	
$t_{IO_PORST_N}$	Time between I/O power on to PORST_N de-assertion	10	-	ms	

3 Function Description Overview

The RT3050 SOC combines Ralink's 802.11n compliant 1T1R MAC/BBP/RF, a high performance 320-MHz MIPS24KEc CPU core, USB OTG controller/PHY, and 5-port 10/100Mbps Ethernet switch and a 5-port UTP PHY, to enable a multitude of high performance, cost-effective 802.11n applications.

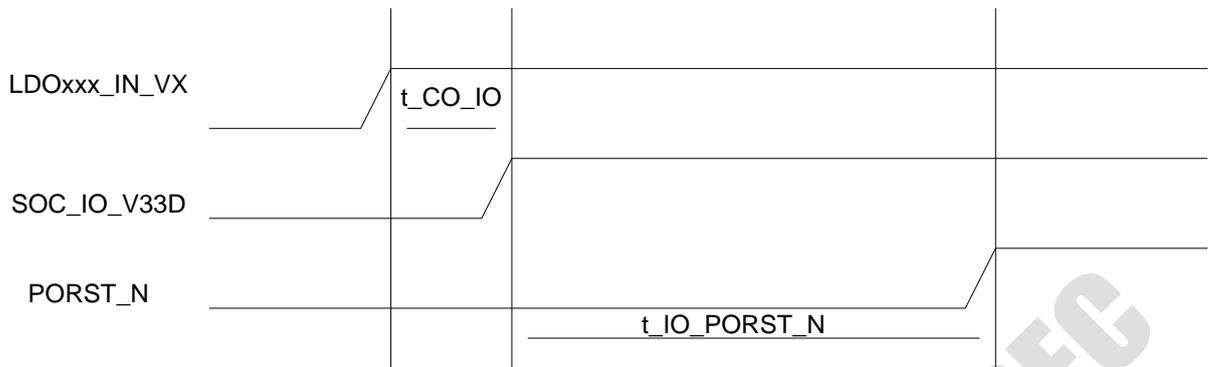
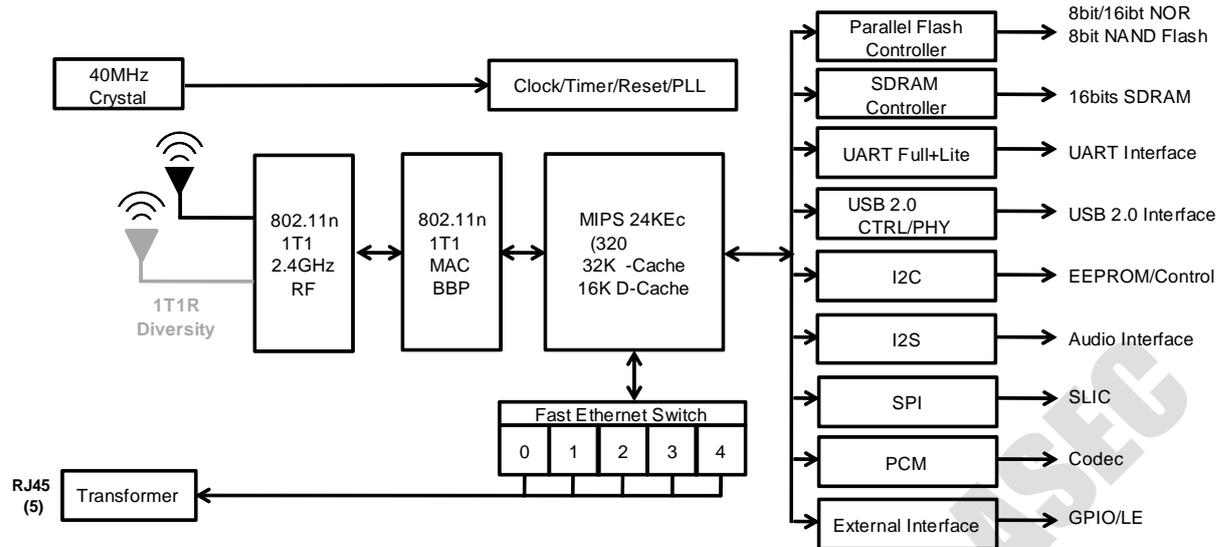

Fig. 3-1-1 RT3050 Block Diagram

There are 4 bus masters (MIPS 24KEc, Ethernet Switch, USB OTG, and 802.11n MAC/BBP/RF) on the RT3050 SoC on a high performance, low latency Ralink Bus (Rbus). In addition, the RT3050 SoC supports lower speed peripherals such as UART, Timer, GPIO, I2C, SPI, I2S and PCM via a low speed peripheral bus (Pbus). The Flash/SDRAM/SDRAM controller is the only bus slave on the Rbus. It includes an Advanced Memory Scheduler to manage the requests from bus masters, enhancing the performance of memory access intensive tasks such as AP/Router packet processing.

The RT3050 has an embedded 5-port 10/100Mbps Ethernet switch and a 5-port UTP PHY. Besides the normal L2 switch function, it also embeds Ralink's patent pending packet processing engine (PPE) to offload AP/Router packet forwarding tasks such as firewall, NAT, NAT and layer 2 bridging from the MIPS CPU. It also features a high performance PDMA (packet DMA) which not only sorts and retrieves packets to and from the SDRAM but also supports CPU offloading packet functions such as IP/TCP/UDP checksum checking/generation, PPPoE session ID insertion and VLAN tag insertion. Ralink's packet processing engine technology enables the RT3050 to perform at the level of higher MHz CPU's.

The RT3050 SoC embeds Ralink's market proven 802.11n 1T1R MAC/BBP/RF to provide a 300Mbps PHY rate on the wireless LAN interface. The MAC design employs a highly efficient DMA engine and hardware data processing accelerators, which free the CPU for user applications. The 802.11n 1T1R MAC/BBP/RF is designed to support standards based features in the area of security, quality of service and international regulation, resulting in an enhanced end user experience.

3.2 Memory Map Summary

Start	End	Size	Description
0000.0000	- 03FF.FFFF	64M	SDRAM
0400.0000	- 0FFF.FFFF		<<Reserved>>
1000.0000	- 1000.00FF	256	SYSCTL

1000.0100	-	1000.01FF	256	TIMER
1000.0200	-	1000.02FF	256	INTCTL
1000.0300	-	1000.03FF	256	MEM_CTRL (SDRAM & Flash/SRAM)
1000.0400	-	1000.04FF	256	PCM
1000.0500	-	1000.05FF	256	UART
1000.0600	-	1000.06FF	256	PIO
1000.0700	-	1000.07FF	256	Generic DMA
1000.0800	-	1000.08FF	256	NAND Flash Controller
1000.0900	-	1000.09FF	256	I2C
1000.0A00	-	1000.0AFF	256	I2S
1000.0B00	-	1000.0BFF	256	SPI
1000.0C00	-	1000.0CFF	256	UARTLITE
1000.0D00	-	100F.FFFF		<<Reserved>>
1010.0000	-	1010.FFFF	64K	Frame Engine
1011.0000	-	1011.7FFF	32K	Ethernet Switch
1011.8000		1011.9FFF	8K	ROM
1011_a000		1011_FFFF		<<Reserved>>
1012.0000	-	1012.7FFF	32K	<<Reserved>>
1012.8000		1012.FFFF	32K	<<Reserved>>
1013.0000	-	1013.7FFF	32K	<<Reserved>>
1013.8000	-	1013.FFFF	32K	<<Reserved>>
1014.0000	-	1017.FFFF	256K	<<Reserved>>
1018.0000	-	101B.FFFF	256K	802.11n MAC/BBP
101C.0000	-	101F.FFFF	256K	USB OTG
1020.0000	-	1AFF.FFFF		<<Reserved>>
1B00.0000	-	1BFF.FFFF	16MB	External SRAM/Flash
1C00.0000	-	1EFF.FFFF		<<Reserved>>
1F00.0000	-	1FFF.FFFF	16MB(flash) or 4KB(ram) or 8KB(rom)	When BOOT_FROM = 2'b00, up-to 16MB external 16-bit flash is mapped. When BOOT_FROM = 2'b01, up-to 8MB external 8-bit flash is mapped. When BOOT_FROM = 2'b10, 4KB internal boot RAM is mapped for boot from NAND application. When BOOT_FROM = 2'b11, 8KB internal boot ROM is mapped for iNIC application.

Note:

When the booting from NAND option is enabled (set boot strapping signal: BOOT_FROM = 2'b10), the access to the external flash will be remapped to the internal 4KB boot SRAM located in USB OTG (0x101E_0000 – 0x101E_3FFF). Accesses to the original flash memory region outside of the 4KB boot SRAM are invalid in this boot from NAND mode. The 4KB SRAM is also accessible from 0x101E_0000 – 0x101E_3FFF memory space.

When the boot from ROM option is enabled (set boot strapping signal: BOOT_FROM = 2'b11), the access to the external flash will be remapped to the internal 8KB boot ROM located in (0x1011_8000 – 0x1011_9FFF). Accesses to the original flash memory region outside of the 8KB boot ROM are invalid in this boot from ROM mode. The 8KB ROM is also accessible from 0x1011_8000 – 0x1011_9FFF memory space.

3.3 MIPS 24KEc Processor

3.3.1 Features

- 8-stage pipeline
- 32-bit address paths

- 64-bit data paths to caches and external interface
- MIPS32-Compatible Instruction Set
- Multiply-Accumulate and Multiply-Subtract Instructions (MADD, MADDU, MSUB, MSUBU)
- Targeted Multiply Instruction (MUL)
- Zero/One Detect Instructions (CLZ, CLO)
- Wait Instruction (WAIT)
- Conditional Move Instructions (MOVZ, MOVN)
- Pre-fetch Instruction (PREF)
- MIPS32 Enhanced Architecture (Release 2) Features
- Vectored interrupts and support for external interrupt controller
- Programmable exception vector base
- Automatic interrupt enable/disable
- GPR shadow registers (optionally, one or three additional shadows can be added to minimize latency for interrupt handlers)
- Bit field manipulation instructions
- MIPS32 Privileged Resource Architecture
- MIPS DSP ASE
- Fractional data types (Q15, Q31)
- Saturating arithmetic
- SIMD instructions operate on 2x16b or 4x8b simultaneously
- 3 additional pairs of accumulator registers
- Programmable Memory Management Unit
- 32 dual-entry JTLB with variable page sizes
- 4-entry ITLB
- 8-entry DTLB
- Optional simple Fixed Mapping Translation (FMT) mechanism
- MIPS16e™ Code Compression
- 16 bit encodings of 32 bit instructions to improve code density
- Special PC-relative instructions for efficient loading of addresses and constants
- SAVE & RESTORE macro instructions for setting up and tearing down stack frames within subroutines
- Improved support for handling 8 and 16 bit data types
- Programmable L1 Cache Sizes
- Instruction cache size: 32KB
- Data cache size: 16KB
- 4-Way Set Associative
- Up to 8 outstanding load misses
- Write-back and write-through support
- 32-byte cache line size

3.3.2 Block Diagram

Fig. 3-3-1 MIPS 24KEc Processor Diagram

3.4 System Control

3.4.1 Features

- Provide read-only chip revision registers
- Provide a window to access boot-strapping signals
- Support memory remapping configurations
- Support software reset to each platform building block
- Provide registers to determine GPIO and other peripheral pin muxing schemes
- Provide some power-on-reset only test registers for software programmers
- Combine miscellaneous registers (such as clock skew control, status register, memo registers,...etc)

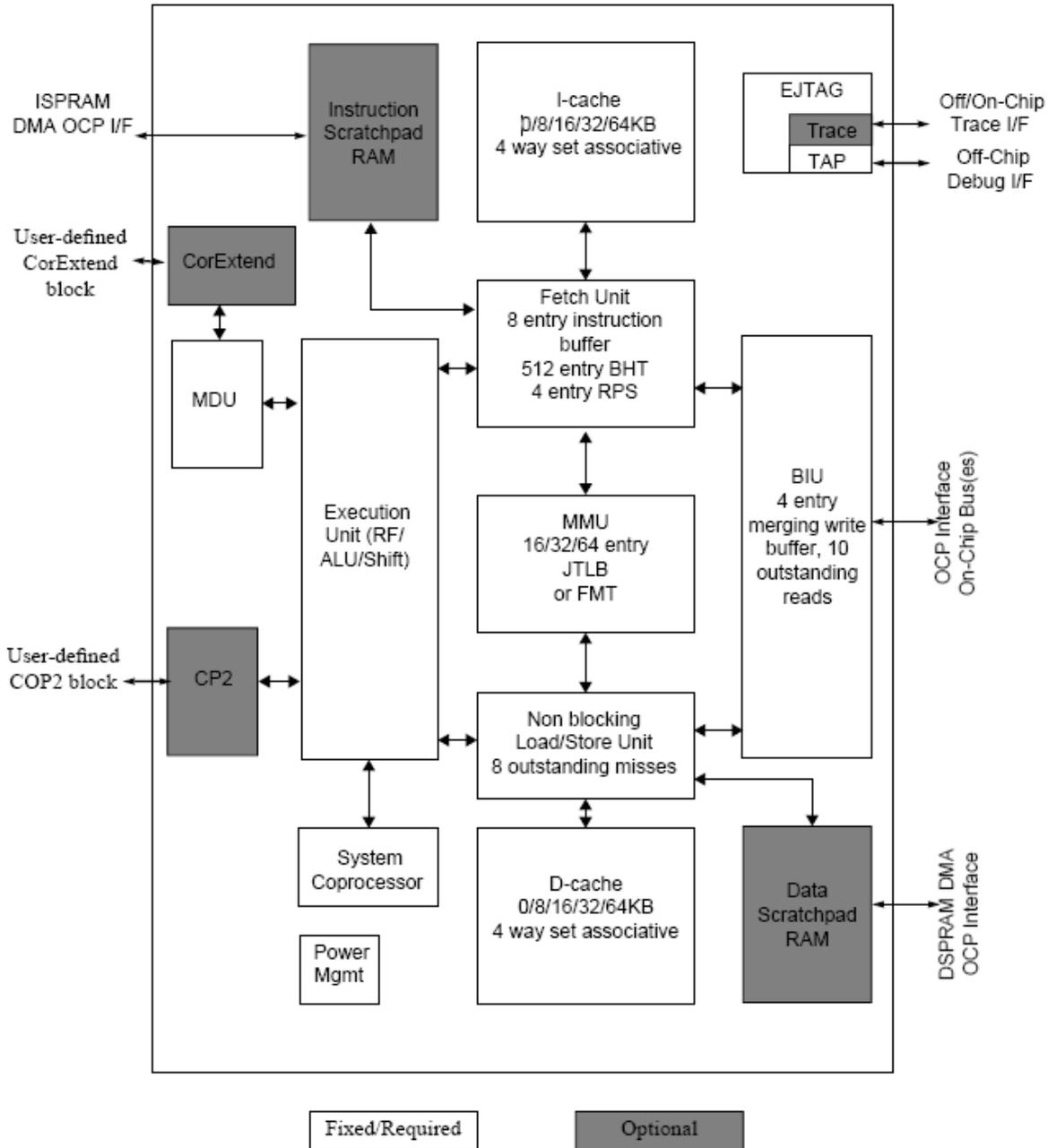
3.4.2 Block Diagram

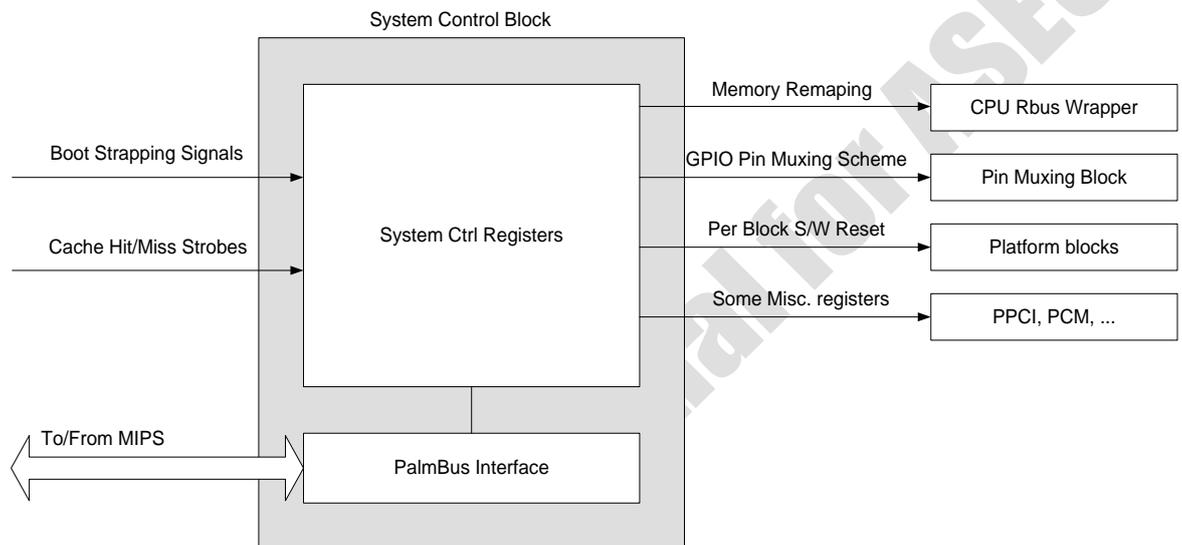

Fig. 3-4-1 System Control Block Diagram

3.4.3 Register Description (base: 0x1000.0000)

CHIPID0_3: Chip ID ASCII Character 0-3 (offset: 0x00)

Bits	Type	Name	Description	Initial value
31:24	RO	CHIP_ID3	ASCII CHIP Name Identification Character 3	8'h30 ('0')
23:16	RO	CHIP_ID2	ASCII CHIP Name Identification Character 2	8'h 33 ('3')
15:8	RO	CHIP_ID1	ASCII CHIP Name Identification Character 1	8'h 54 ('T')
7:0	RO	CHIP_ID0	ASCII CHIP Name Identification Character 0	8'h 52 ('R')

CHIPID4_7: Chip Name ASCII Character 4-7 (offset: 0x04)

Bits	Type	Name	Description	Initial value
31:24	RO	CHIP_ID7	ASCII CHIP Name Identification Character 7	8'h 20 ('')
23:16	RO	CHIP_ID6	ASCII CHIP Name Identification Character 6	8'h 20 ('')
15:8	RO	CHIP_ID5	ASCII CHIP Name Identification Character 5	8'h 32 ('2')
7:0	RO	CHIP_ID4	ASCII CHIP Name Identification Character 4	8'h 35 ('5')

SYSCFG: System Configuration Register (offset: 0x10)

Bits	Type	Name	Description	Initial value
31:30	-	-	Reserved	2'b0
29	RO	INIC_EE_SDRAM	0: Disregard EEPROM SDRAM configuration for iNIC 1: Take SDRAM configuration for iNIC from EEPROM if available Note: There is no special H/W function related to the setting of this bit. That means the firmware could use it for other purposes (as a general purpose bootstrapping).	Bootstrap

28	RO	INIC_8MB_SDRAM	0: SDRAM configuration is 2MB for iNIC 1: SDRAM configuration is 8MB for iNIC Note: There is no special H/W function related to the setting of this bit. That means the firmware could use it for other purposes (as a general purpose bootstrapping).	Bootstrap
27:26	-	-	Reserved	2'b0
25:24	-	-	Reserved	2'b00
23	-	-	Reserved	1'b0
22	RO	BOOT_ADDR	0: CPU boots at address 0x1FC00000 1: CPU boots at address 0x1F000000	1'b0
21	RO-	BYPASS_PLL	0: Not bypass PLL 1: Bypass PLL	Bootstrap
20	RO	BIG_ENDIAN	0: Little endian 1: Big endian	Bootstrap
19	-	-	Reserved	1'b0
18	RO	CPU_CLK_SEL	0: 320Mhz 1: 384 MHz Note: System clock is 1/3 of the CPU CLK	Bootstrap
17:16	RO	BOOT_FROM	2'b00: boot from external 16-bit flash (default) 2'b01: boot from external 8-bit flash 2'b10: boot from external NAND flash 2'b11: boot from internal ROM	Bootstrap
15:8	R/W	TEST_CODE[7:0]	Probe signals selection Default value is from bootstrap and can be modified by software	Bootstrap
7:4	-	-	Reserved	7'b0
3:2	WO	SRAM_CS_MODE	2'b00: Normal SRAM chip select output (active low) 2'b01: Watch dog reset output (active low for 3 system clocks) 2'b10: BT coexistence signal "WLAN_ACT" output 2'b11: Reserved Note: These two bits are write only. The read value is always 2'b00.	2'b00
1	-	-	Reserved	1'b0
0	WO	SDRAM_CLK_DRV	1'b0: 8mA SDRAM_CLK driving 1'b1: 12mA SDRAM_CLK driving Note: This bit is write only. The read value is always 1'b0.	1'b0

Reserved register (offset: 0x14)

Bits	Type	Name	Description	Initial value
31:0	-	-	Reserved	32'b0

TESTSTAT: Firmware Test Status Register (offset: 0x18)

Bits	Type	Name	Description	Initial value
31:0	R/W	TSETSTAT[31:0]	Firmware Test Status Note: This register is reset only by power on reset.	32'b0

TESTSTAT2 : Firmware Test Status Register 2 (offset: 0x1C)

Bits	Type	Name	Description	Initial value
31:0	R/W	TSETSTAT2[31:0]	Firmware Test Status 2 Note: This register is reset only by power on reset.	32'b0

Reserved register (offset: 0x20)

Bits	Type	Name	Description	Initial value
31:0	-	-	Reserved	32'b0

Reserved register (offset: 0x24)

Bits	Type	Name	Description	Initial value
31:0	-	-	Reserved	32'b0

Reserved register (offset: 0x28)

Bits	Type	Name	Description	Initial value
31:0	-	-	Reserved	32'b0

CLKCFG0: Clock Configuration Register 0 (offset: 0x2C)

Bits	Type	Name	Description	Initial value
31:30	R/W	SDRAM_CLK_SKEW	0: zero delay 1: delay 1ns 2: delay 2ns 3: delay 3ns	2'b01
29:0	-	-	Reserved	30'b0

CLKCFG1: Clock Configuration Register 1 (offset: 0x30)

Bits	Type	Name	Description	Initial value
31	-	-	Reserved	1'b0
30	R/W	PBUS_DIV2	0: Pbus clock is running at the same frequency as System clock 1: Pbus clock is running at 1/2 frequency of System clock	1'b0
29:19	-	-	Reserved	11'b0
18	R/W	OTG_CLK_EN	0: USB OTG clock is gated 1: USB OTG clock is enabled	1'b1
17:16	-	-	Reserved	2'b0
15	R/W	I2S_CLK_EN	0: I2S clock is gated 1: I2S clock is enabled	1'b0
14	R/W	I2S_CLK_SEL	I2S reference select 1'b0: internal 15.625Mhz reference clock 1'b1: external reference clock	1'b0
13:8	R/W	I2S_CLK_DIV	I2S clock divider The source of this divider comes from two sources. One is from REF_CLK (see 2.2 Pin sharing scheme-UARTF share mode) and the other is from internal 15.625 MHz reference clock. The I2S clock divider will divide the reference clock by (I2S_CLK_DIV+1). The final I2S_CLK is obtained from the divided reference clock or external REF_CLK clock, depending on I2S_CLK_SEL setting.	6'h28
7	R/W	PCM_CLK_EN	0: PCM clock is gated 1: PCM clock is enabled	1'b0
6	R/W	PCM_CLK_SEL	PCM reference select 1'b0: internal 15.625Mhz reference clock 1'b1: external reference clock	1'b0
5:0	R/W	PCM_CLK_DIV	PCM clock divider The source of this divider comes from two places. One is from REF_CLK (see 2.2 Pin sharing scheme-UARTF share mode) and the other is from internal 15.625Mhz reference clock. The PCM clock divider will divide the reference clock by (PCM_CLK_DIV+1). The final PCM_CLK is obtained from the divided reference clock or external REF_CLK clock depending on the PCM_CLK_SEL setting.	6'h3c

RSTCTRL: Reset Control Register (offset: 0x34)

Bits	Type	Name	Description	Initial value
31:24	-	-	Reserved	8'b0

23	W1C	SW_RST	Write 1 to this bit will reset Ethernet Switch block	1'b0
22	W1C	OTG_RST	Write 1 to this bit will reset USB OTG block	1'b0
21	W1C	FE_RST	Write 1 to this bit will reset Frame Engine block	1'b0
20	W1C	WLAN_RST	Write 1 to this bit will reset WLAN block	1'b0
19	W1C	UARTL_RST	Write 1 to this bit will reset UART Lite block	1'b0
18	W1C	SPI	Write 1 to this bit will reset SPI block	1'b0
17	W1C	I2S	Write 1 to this bit will reset I2S block	1'b0
16	W1C	I2C	Write 1 to this bit will reset I2C block	1'b0
15	-	-	Reserved	1'b0
14	W1C	DMA	Write 1 to this bit will reset DMA block	1'b0
13	W1C	PIO	Write 1 to this bit will reset PIO block	1'b0
12	W1C	UART_RST	Write 1 to this bit will reset UART block	1'b0
11	W1C	PCM_RST	Write 1 to this bit will reset PCM block	1'b0
10	W1C	MC_RST	Write 1 to this bit will reset Memory Controller block	1'b0
9	W1C	INTC_RST	Write 1 to this bit will reset Interrupt Controller block	1'b0
8	W1C	TIMER_RST	Write 1 to this bit will reset Timer block	1'b0
7:1	-	-	Reserved	6'b0
0	W1C	SYS_RST	Write 1 to this bit will reset Whole SoC	1'b0

RSTSTAT: Reset Status Register (offset: 0x38)

Bits	Type	Name	Description	Initial value
31:4	-	-	Reserved	28'b0
3	R/C	SWCPURST	A Software CPU reset has occurred This bit will be set if software reset the CPU by writing to the RSTCPU bit in RSTCTL. Writing a '1' will clear this bit. Writing a '0' has not effect. Note: This register is reset only by power on reset.	1'b0
2	R/C	SWSYSRST	Software system reset occurred This bit will be set if software reset the chip by writing to the RSTSYS bit in RSTCTL. Writing a '1' will clear this bit. Writing a '0' has not effect. Note: This register is reset only by power on reset.	1'b0
1	R/C	WDRST	Watchdog reset occurred This bit will be set if the watchdog timer reset the chip. Writing a '1' will clear this bit. Writing a '0' has not effect. Note: This register is reset only by power on reset.	1'b0
0	-	-	Reserved	1'b0

GPIOMODE: GPIO Purpose Select (offset: 0x60)

Bits	Type	Name	Description	Initial value
31:7	-	-	Reserved	25'b0
6	R/W	JTAG_GPIO_MODE	0:Normal Mode 1:GPIO Mode Control GPIO[21:17]	1'b0
5	R/W	UARTL_GPIO_MODE	0:Normal Mode 1:GPIO Mode Control GPIO[16:15]	1'b1
4:2	R/W	UARTF_SHARE_MODE	UARTF Full interface is shared with PCM, REFCLK, I2S, GPIO [14:7]. The detailed UARTF Mode Pin Sharing is shown in previous session.	3'b111
1	R/W	SPI_GPIO_MODE	0:Normal Mode 1:GPIO Mode Control GPIO[6:3]	1'b1
0	R/W	I2C_GPIO_MODE	0:Normal Mode 1:GPIO Mode	1'b1

			Control GPIO[2:1]	
--	--	--	-------------------	--

MEMO0: Firmware Memo Register1 (offset: 0x68)

Bits	Type	Name	Description	Initial value
31:0	R/W	MEMO1[31:0]	Firmware Memo register 1 Note: This register is reset only by power on reset.	32'b0

MEMO1: Firmware Memo Register 2 (offset: 0x6C)

Bits	Type	Name	Description	Initial value
31:0	R/W	MEMO2[31:0]	Firmware Memo register 0 Note: This register is reset only by power on reset.	32'b0

Ralink Confidential for ASEC

3.5 Timer

3.5.1 Features

- Independent clock pre-scale for each timer
- Independent interrupts for each timer
- Two General-purpose timers
- Periodic mode

- Free-running mode
- Time-out mode
- Second timer may be used as watchdog timer
- Watchdog timer resets system on time-out

3.5.2 Block Diagram

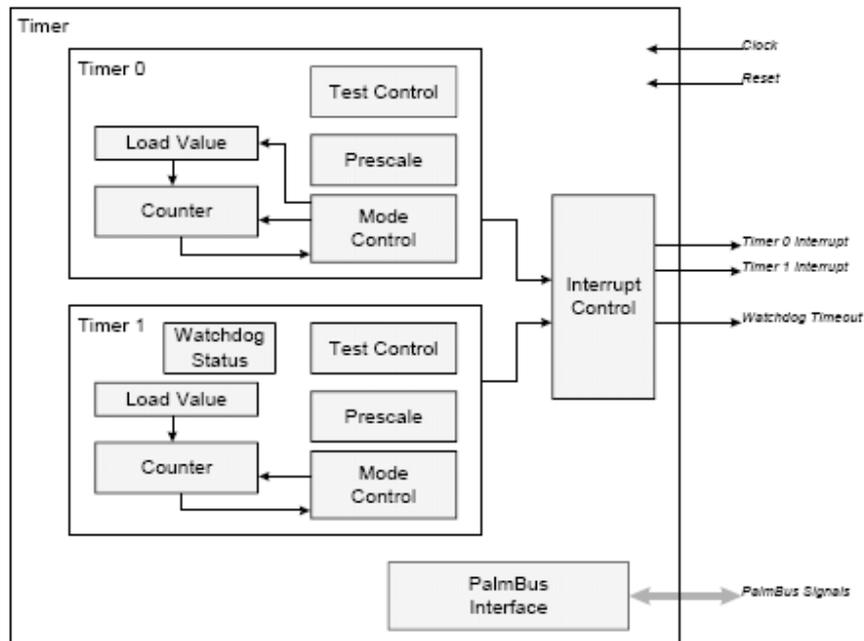

Fig. 3-5-1 Timer Block Diagram

3.5.3 Register Description (base: 0x1000.0100)

TMRSTAT: Timer Status Register (offset: 0x00)

Bits	Type	Name	Description	Initial value
31:6	-	-	Reserved	26'b0
5	W	TMR1RST	Timer 1 Reset Writing a '1' to this bit will reset the Timer 1 to 0xFFFF if in free-running mode, or the value specified in the TMR1LOAD register in all other modes. Writing a '0' to this bit has no effect. Reading this bit will return a '0'.	1'b0
4	W	TMR0RST	Timer 0 Reset Writing a '1' to this bit will reset Timer 0 to 0xFFFF if in free-running mode, or the value specified in the TMR0LOAD register in all other modes. Writing a '0' to this bit has no effect. Reading this bit will return a '0'.	1'b0
3:2	-	-	Reserved	2'b0
1	W/C	TMR1INT	Timer 1 Interrupt Status This bit is set if Timer 1 has expired. The Timer 1 interrupt to the processor is set when this bit is '1'. Writing a '1' to this bit will clear the interrupt. Writing a '0' has no effect.	1'b0
0	W/C	TMR0INT	Timer 0 Interrupt Status This bit is set if Timer 0 has expired. The Timer 0 interrupt to the processor is set when this bit is '1'. Writing a '1' to this bit will clear the interrupt. Writing a '0' has no effect.	1'b0

TMR0LOAD: Timer 0 Load Value (offset: 0x10)

Bits	Type	Name	Description	Initial value
31:16	R-	-	Reserved	16'b0
15:0	R/W	TMRLOAD[15:0]	Timer Load Value This register contains the load value for the timer. In all modes, this value is loaded into the timer counter when this register is written. In all modes except free-running mode, this value is reloaded into the timer counter after the timer counter reaches 0. It may be updated at any time; the new value will be written to the counter immediately. Writing a load value of 0 will disable the timer, except in free-running mode.	16'b0

TMR0VAL: Timer 0 Counter Value (offset: 0x14)

Bits	Type	Name	Description	Initial value
31:16	-	-	Reserved	16'b0
15:0	RO	TMRVAL[15:0]	Timer Counter Value This register contains the current value of the timer. During functional operation, writes have no effect.	16'hffff

TMR0CTL: Timer 0 Control (offset: 0x18)

Bits	Type	Name	Description	Initial value																
31:16	-	-	Reserved	16'b0																
15	R/W	TESTEN	Reserved for Test This bit should be written with a zero	1'b0																
14:8	-	-	Reserved	15'b0																
7	R/W	ENABLE	Timer Enable 0: Disable the timer. The timer will stop counting and will retain its current value. 1: Enable the timer. The timer will begin counting from its current value.	1'b0																
6	-	-	Reserved	1'b0																
5:4	R/W	MODE[1:0]	Timer Mode 0: Free-running 1: Periodic 2: Time-out 3: Time-out	1'b0																
3:0	R/W	PRESCALE[3:0]	Timer Clock Pre-scale These bits are used to scale the timer clock in order to achieve higher resolution or longer timer periods. Their definitions are below. <table border="1" data-bbox="662 1473 1268 1724"> <thead> <tr> <th>Value</th> <th>Timer Clock Frequency</th> </tr> </thead> <tbody> <tr> <td>1</td> <td>System clock</td> </tr> <tr> <td>2</td> <td>System clock / 4</td> </tr> <tr> <td>3</td> <td>System clock / 8</td> </tr> <tr> <td>.</td> <td>System clock / 16</td> </tr> <tr> <td>.</td> <td>.</td> </tr> <tr> <td>14</td> <td>System clock / 32768</td> </tr> <tr> <td>15</td> <td>System clock / 65536</td> </tr> </tbody> </table> Note: The pre-scale value should not be changed unless the timer is disabled.	Value	Timer Clock Frequency	1	System clock	2	System clock / 4	3	System clock / 8	.	System clock / 16	.	.	14	System clock / 32768	15	System clock / 65536	4'b0
Value	Timer Clock Frequency																			
1	System clock																			
2	System clock / 4																			
3	System clock / 8																			
.	System clock / 16																			
.	.																			
14	System clock / 32768																			
15	System clock / 65536																			

TMR1LOAD: Timer 1 Load Value (offset: 0x20)

Bits	Type	Name	Description	Initial value
31:16	-	-	Reserved	16'b0
15:0	R/W	TMRLOAD[15:0]	Timer Load Value This register contains the load value for the timer. In all modes, this value is loaded into the timer counter when this register is written. In all modes except free-running	16'b0

			mode, this value is reloaded into the timer counter after the timer counter reaches 0. It may be updated at any time; the new value will be written to the counter immediately. Writing a load value of 0 will disable the timer, except in free-running mode.	
--	--	--	--	--

TMR1VAL: Timer 1 Counter Value (offset: 0x24)

Bits	Type	Name	Description	Initial value
31:16	-	-	Reserved	16'b0
15:0	RO	TMRVAL[15:0]	Timer Counter Value This register contains the current value of the timer. During functional operation, writes have no effect.	16'hffff

TMR1CTL: Timer 1 Control (offset: 0x28)

Bits	Type	Name	Description	Initial value																		
31:16	-	-	Reserved	16'b0																		
15	R/W	TESTEN	Reserved for Test This bit should be written with a zero	1'b0																		
14:8	-	-	Reserved	7'b0																		
7	R/W	ENABLE	Timer Enable 0: Disable the timer. The timer will stop counting and will retain its current value. 1: Enable the timer. The timer will begin counting from its current value.	1'b0																		
6	-	-	Reserved	1'b0																		
5:4	R/W	MODE[1:0]	Timer Mode 0: Free-running 1: Periodic 2: Time-out 3: Watchdog	1'b0																		
2:0	R/W	PRESCALE[3:0]	Timer Clock Pre-scale These bits are used to scale the timer clock in order to achieve higher resolution or longer timer periods. Their definitions are below. <table border="1" data-bbox="662 1332 1316 1635"> <thead> <tr> <th>Value</th> <th>Timer Clock Frequency</th> </tr> </thead> <tbody> <tr><td>0</td><td>System clock</td></tr> <tr><td>1</td><td>System clock / 4</td></tr> <tr><td>2</td><td>System clock / 8</td></tr> <tr><td>3</td><td>System clock / 16</td></tr> <tr><td>.</td><td>.</td></tr> <tr><td>.</td><td>.</td></tr> <tr><td>14</td><td>System clock / 32768</td></tr> <tr><td>15</td><td>System clock / 65536</td></tr> </tbody> </table> Note: The pre-scale value should not be changed unless the timer is disabled.	Value	Timer Clock Frequency	0	System clock	1	System clock / 4	2	System clock / 8	3	System clock / 16	14	System clock / 32768	15	System clock / 65536	3'b0
Value	Timer Clock Frequency																					
0	System clock																					
1	System clock / 4																					
2	System clock / 8																					
3	System clock / 16																					
.	.																					
.	.																					
14	System clock / 32768																					
15	System clock / 65536																					

3.6 Interrupt Controller

3.6.1 Features

- Support a central point for interrupt aggregation for platform related blocks
- Separated interrupt enable and disable registers
- Support global disable function
- 2-level Interrupt priority selection
- Each interrupt source can be directed to IRQ#0 or IRQ#1

Note: RT3050 supports MIPS 24KEc's vector interrupt mechanism.

There are 6 hardware interrupts supported by MIPS 24KEc. The interrupt allocation is shown below:

MIPS H/W interrupt pins	Connect to	Remark
HW_INT#5	Timer interrupt	Highest priority
HW_INT#4	802.11n NIC	
HW_INT#3	Frame Engine	
HW_INT#2	Reserved	
HW_INT#1	Other high priority interrupts (IRQ#1)	
HW_INT#0	Other low priority interrupts (IRQ#0)	Lowest priority

3.6.2 Block Diagram

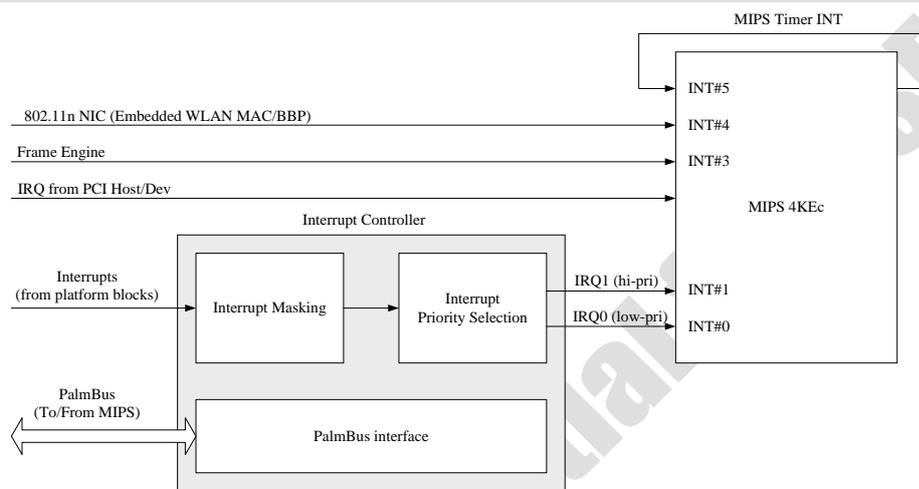

Fig. 3-6-1 Interrupt Controller Block Diagram

3.6.3 Register Description (base: 0x1000.0200)

IRQ0STAT: Interrupt Type 0 Status after Enable Mask (offset: 0x00)

Bits	Type	Name	Description	Initial value
31:19	-	-	Reserved	13'b0
18	RO	OTG	OTG interrupt status after mask	1'b0
17	RO	ESW	Ethernet switch interrupt status after mask	1'b0
16	-	-	Reserved	1'b0
15:13	-	-	Reserved	3'b0
12	RO	UARTLITE	UARTLITE interrupt status after mask	1'b0
11	RO	-	Reserved	1'b0
10	RO	I2S	I2S interrupt status after mask	1'b0
9	RO	PC	MIPS performance counter interrupt status after mask	1'b0
8	RO	NAND	NAND flash controller interrupt status after mask	1'b0
7	RO	DMA	DMA interrupt status after mask	1'b0
6	RO	PIO	PIO interrupt status after mask	1'b0
5	RO	UART	UART interrupt status after mask	
4	RO	PCM	PCM interrupt status after mask	1'b0
3	RO	ILL_ACC	Illegal access interrupt status after mask	1'b0
2	RO	WDTIMER	Watch dog timer interrupt status after mask	1'b0
1	RO	TIMER0	Timer 0 interrupt status after mask	1'b0
0	RO	SYSCTL	System control interrupt status after mask	1'b0

These bits are set if the corresponding interrupt are asserted from the source and with following two conditions:

- The interrupt is not masked (bit not set in the INTDIS register)
- The interrupt type is set to INTO (in the INTTYPE register).

Note that writing to these bits is ignored and each bit cannot be simultaneously active in both the IRQ0STAT and IRQ1STAT registers.

IRQ1STAT: Interrupt Type 1 Status after Enable Mask (offset: 0x04)

Bits	Type	Name	Description	Initial value
31:19	-	-	Reserved	13'b0
18	RO	OTG	OTG interrupt status after mask	1'b0
17	RO	ESW	Ethernet switch interrupt status after mask	1'b0
16	-	-	Reserved	1'b0
15:13	-	-	Reserved	3'b0
12	RO	UARTLITE	UARTLITE interrupt status after mask	1'b0
11	-	-	Reserved	1'b0
10	RO	I2S	I2S interrupt status after mask	1'b0
9	RO	PC	MIPS performance counter interrupt status after mask	1'b0
8	RO	NAND	NAND flash controller interrupt status after mask	1'b0
7	RO	DMA	DMA interrupt status after mask	1'b0
6	RO	PIO	PIO interrupt status after mask	1'b0
5	RO	UART	UART interrupt status after mask	1'b0
4	RO	PCM	PCM interrupt status after mask	1'b0
3	RO	ILL_ACC	Illegal access interrupt status after mask	1'b0
2	RO	WDTIMER	Watch dog timer interrupt status after mask	1'b0
1	RO	TIMER0	Timer 0 interrupt status after mask	1'b0
0	RO	SYSCTL	System control interrupt status after mask	1'b0

These bits are set if the corresponding interrupt is asserted from the source and with following two conditions:

- The interrupt is not masked (bit not set in the INTDIS register)
- The interrupt type is set to INT1 (in the INTTYPE register).

Note that writing to these bits is ignored and each bit cannot be simultaneously active in both the IRQ0STAT and IRQ1STAT registers.

INTTYPE: Interrupt Type (offset: 0x20)

Bits	Type	Name	Description	Initial value
31:19	-	-	Reserved	13'b0
18	R/W	OTG	OTG interrupt status type	1'b0
17	R/W	ESW	Ethernet switch interrupt status type	1'b0
16	-	-	Reserved	1'b0
15:13	-	-	Reserved	3'b0
12	R/W	UARTLITE	UARTLITE interrupt status type	1'b0
11	-	-	Reserved	1'b0
10	R/W	I2S	I2S interrupt status type	1'b0
9	R/W	PC	MIPS performance counter interrupt status type	1'b0
8	R/W	NAND	NAND flash controller interrupt status type	1'b0
7	R/W	DMA	DMA interrupt status after type	1'b0
6	R/W	PIO	PIO interrupt status after type	1'b0
5	R/W	UART	UART interrupt status type	1'b0
4	R/W	PCM	PCM interrupt status type	1'b0
3	R/W	ILL_ACC	Illegal access interrupt status type	1'b0
2	R/W	WDTIMER	Watch dog timer interrupt status type	1'b0
1	R/W	TIMER0	Timer 0 interrupt status type	1'b0
0	R/W	SYSCTL	System control interrupt status type	1'b0

These bits control whether an interrupt is IRQ0 or IRQ1. The interrupt type may be changed at any time. If the interrupt type is changed while the interrupt is active, the interrupt is immediately redirected.

INTRAW: Raw Interrupt Status before Enable Mask (offset: 0x30)

Bits	Type	Name	Description	Initial value
------	------	------	-------------	---------------

31:19	-	-	Reserved	13'b0
18	RO	OTG	OTG interrupt status before mask	1'b0
17	RO	ESW	Ethernet switch interrupt status before mask	1'b0
16	-	-	Reserved	1'b0
15:13	-	-	Reserved	3'b0
12	RO	UARTLITE	UARTLITE interrupt status before mask	1'b0
11	RO	-	Reserved	1'b0
10	RO	I2S	I2S interrupt status before r mask	1'b0
9	RO	PC	MIPS performance counter interrupt status before mask	1'b0
8	RO	NAND	NAND flash controller interrupt status before mask	1'b0
7	RO	DMA	DMA interrupt status before mask	1'b0
6	RO	PIO	PIO interrupt status before mask	1'b0
5	RO	UART	UART interrupt status before mask	1'b0
4	RO	PCM	PCM interrupt status before mask	1'b0
3	RO	ILL_ACC	Illegal access interrupt status before mask	1'b0
2	RO	WDTIMER	Watch dog timer interrupt status before mask	1'b0
1	RO	TIMERO	Timer 0 interrupt status before mask	1'b0
0	RO	SYSCTL	System control interrupt status before mask	1'b0

These bits are set if the corresponding interrupt is asserted from the source. The status bit is set if the interrupt is active, even if it is masked and regardless of the interrupt type. This provides a single-access snapshot of all active interrupts for implementation of a polling system.

INTENA: Interrupt Enable (offset: 0x34)

Bits	Type	Name	Description	Initial value
31	R/W	GLOBAL	Global interrupt enable Writing a '1' to this bit allows interrupt masking to be performed based on each interrupt's individual enable mask. A read returns the global status ('1' if enabled).	1'b0
30:19	-	-	Reserved	12'b0
18	R/W	OTG	OTG interrupt status after mask	1'b0
17	R/W	ESW	Ethernet switch interrupt status after mask	1'b0
16	-	-	Reserved	1'b0
15:13	-	-	Reserved	3'b0
12	R/W	UARTLITE	UARTLITE interrupt status after mask	1'b0
11	-	-	Reserved	1'b0
10	R/W	I2S	I2S interrupt enable	1'b0
9	R/W	PC	MIPS performance counter interrupt enable	1'b0
8	RW	NAND	NAND flash controller interrupt enable	1'b0
7	RW	DMA	DMA interrupt enable	1'b0
6	RW	PIO	PIO interrupt enable	1'b0
5	RW	UART	UART interrupt enable	1'b0
4	RW	PCM	PCM interrupt enable	1'b0
3	RW	ILL_ACC	Illegal access interrupt enable	1'b0
2	RW	WDTIMER	Watch dog timer interrupt enable	1'b0
1	RW	TIMERO	Timer 0 interrupt enable	1'b0
0	RW	SYSCTL	System control interrupt enable	1'b0

Writing a '1' to these bits (except the GLOBAL bit) will enable the mask for the corresponding interrupt. The interrupt is asserted and the bit is set in the IRQ0STAT or IRQ1STAT registers if an interrupt is enabled. Writes of '0' are ignored. Reading either the INTENA or INTDIS register will return the current mask, where an interrupt is masked (disabled) if the bit is 'zero', and unmasked (enabled) if the bit is 'one'.

INTDIS: Interrupt Disable (offset: 0x38)

Bits	Type	Name	Description	Initial value
31	R/W	GLOBAL	Global interrupt disable	1'b0

			Writing a '1' to this bit allows interrupt masking to be performed based on each interrupt's individual Disable mask. A read returns the global status ('1' if Disabled).	
30:19	-	-	Reserved	12'b0
18	R/W	OTG	OTG interrupt disable	1'b0
17	R/W	ESW	Ethernet switch interrupt disable	1'b0
16	-	-	Reserved	1'b0
15:13	-	-	Reserved	3'b0
12	R/W	UARTLITE	UARTLITE interrupt s disable	1'b0
11	-	-	Reserved	1'b0
10	R/W	I2S	I2S interrupt disable	1'b0
9	R/W	PC	MIPS performance counter interrupt disable	1'b0
8	RW	NAND	NAND flash controller interrupt disable	1'b0
7	RW	DMA	DMA interrupt disable	1'b0
6	RW	PIO	PIO interrupt disable	1'b0
5	RW	UART	UART interrupt disable	1'b0
4	RW	PCM	PCM interrupt disable	1'b0
3	RW	ILL_ACC	Illegal access interrupt disable	1'b0
2	RW	WDTIMER	Watch dog timer interrupt disable	1'b0
1	RW	TIMER0	Timer 0 interrupt disable	1'b0
0	RW	SYSCTL	System control interrupt enable	1'b0

Writing a '1' to these bits (except the GLOBAL bit) will disable the mask for the corresponding interrupt. The interrupt is asserted and the bit is set in the IRQ0STAT or IRQ1STAT registers if an interrupt is enabled. Writing '0' is ignored. Reading either the INTENA or INTDIS register will return the current mask, where an interrupt is masked (disabled) if the bit is 'zero', and unmasked (enabled) if the bit is 'one'.

3.7 UART

3.7.1 Features

- 16550-compatible register set, except for the Divisor Latch register
- 5-8 data bits
- 1-2 stop bits (1 or 2 stop bits are supported with 5 data bits)
- Even, odd, stick or no parity
- All standard baud rates from 40 b/s to 2.5 Mb/s
- 16-byte receive buffer
- 16-byte transmit buffer
- Receive buffer threshold interrupt
- Transmit buffer threshold interrupt

- False start bit detection in asynchronous mode
- Internal diagnostic capabilities
- Break simulation

3.7.2 Loop-back control for communications link fault isolation Block Diagram

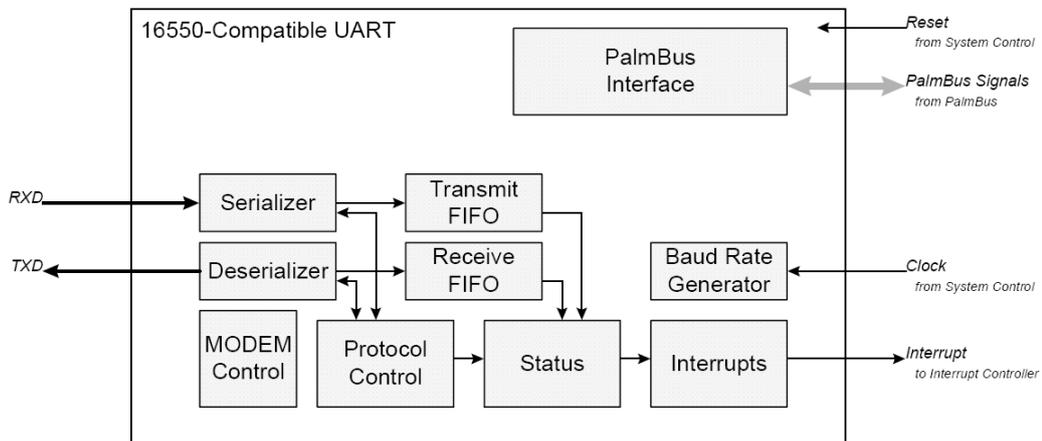

Fig. 3-7-1 UART Block Diagram

3.7.3 Register Description (base: 0x1000.0500)

RBR: Receive Buffer Register (offset: 0x00)

Bits	Type	Name	Description	Initial value
31:8	-	-	Reserved	24'b0
7	RO	RXD[7:0]	Receive Buffer Data Receive data. Data is transferred to this register from the receive shift register after a full character is received. The OE bit in the LSR register is set, indication a receive buffer overrun, if the contents of this register has not been read before another character is received.	1'b0

TBR: Transmit Buffer Register (offset: 0x04)

Bits	Type	Name	Description	Initial value
31:8	-	-	Reserved	24'b0
7	RO	TXD[7:0]	Transmit Buffer Data Transmit data. When a character is written to this register, it is stored in the transmitter holding register; if the transmitter register is empty, the character is moved to the transmitter register, starting transmission.	1'b0

IER: Interrupt Enable Register (offset: 0x08)

Bits	Type	Name	Description	Initial value
31:4	-	-	Reserved	28'b0
3	R/W	EDSSI	Enable Modem Interrupt 1: modem status (DCD, RI, DSR, CTS, DDCD, TERI, DDSR, and DCTS) interrupts. 0: Disable modem status (DCD, RI, DSR, CTS, DDCD, TERI, DDSR, DCTS) interrupts.	1'b0
2	R/W	ELSI	Enable Receiver Line Status Interrupt 1: Enable line status (OE, PE, FE, and BI) interrupts. 0: Disable line status (OE, PE, FE, and BI) interrupts.	1'b0
1	R/W	ETBEI	Enable Transmitter Buffer Line Status Interrupt 1: Enable transmit buffer empty (THRE) interrupt. 0: Disable transmit buffer empty (THRE) interrupt.	1'b0

0	R/W	ERBFI	Enable Receiver Buffer Empty Interrupt 1: Enable data ready (DR) or character time-out interrupt. 0: Disable data ready (DR) or character time-out interrupt.	1'b0
---	-----	-------	---	------

IIR: Interrupt Identification Register (offset: 0x0C)

Bits	Type	Name	Description	Initial value																																								
31:8	-	-	Reserved	24'b0																																								
7:6	RO	FIFOENA[1:0]	FIFOs Enabled FIFOs Enabled. These bits reflect the FIFO enable bit setting in the FIFO Control Register. When the FIFO enable bit is set, both of these bits will be set high to a value of '11'. When the FIFO enable bit is cleared, both of these bits will be set low to a value of '00'.	1'b0																																								
5:4	-	-	Reserved	2'b0																																								
3:1	RO	INTID[2:0]	<p>Interrupt Identifier Interrupt ID. These bits provide a snapshot of the interrupt type, and may be used as the offset into an interrupt vector table. The interrupt encoding is given below.</p> <table border="1" data-bbox="614 824 1308 1205"> <thead> <tr> <th>ID</th> <th>Priority</th> <th>Type</th> <th>Source</th> </tr> </thead> <tbody> <tr><td>7</td><td></td><td>Undefined</td><td></td></tr> <tr><td>6</td><td></td><td>Undefined</td><td></td></tr> <tr><td>5</td><td></td><td>Undefined</td><td></td></tr> <tr><td>4</td><td></td><td>Undefined</td><td></td></tr> <tr><td>3</td><td>1</td><td>Receiver Line</td><td>OE,PE,FE,BI</td></tr> <tr><td>2</td><td>2</td><td>Status</td><td>DR</td></tr> <tr><td>1</td><td>3</td><td>Receiver Buffer Full</td><td>THRE</td></tr> <tr><td>0</td><td></td><td>Transmit buffer Empty</td><td></td></tr> <tr><td></td><td></td><td>Undefined</td><td></td></tr> </tbody> </table> <p>If more than one category of interrupt is asserted, only the highest priority ID will be given. The line and Modem status interrupts are cleared by reading the corresponding status register (LSR, MSR). The Receive Buffer Full interrupt will be cleared when all of the data is read from the receiver buffer. The Transmitter Buffer empty will be cleared when data is written to the TBR register. See also "Interrupt Priorities".</p>	ID	Priority	Type	Source	7		Undefined		6		Undefined		5		Undefined		4		Undefined		3	1	Receiver Line	OE,PE,FE,BI	2	2	Status	DR	1	3	Receiver Buffer Full	THRE	0		Transmit buffer Empty				Undefined		3'b1
ID	Priority	Type	Source																																									
7		Undefined																																										
6		Undefined																																										
5		Undefined																																										
4		Undefined																																										
3	1	Receiver Line	OE,PE,FE,BI																																									
2	2	Status	DR																																									
1	3	Receiver Buffer Full	THRE																																									
0		Transmit buffer Empty																																										
		Undefined																																										
0	RO	INTPEND	Interrupt Pending 0: An interrupt bit is set and is not masked. 1: No interrupts are pending.	1'b0																																								

FCR: FIFO Control Register (offset: 0x10)

Bits	Type	Name	Description	Initial value
31:8	-	-	Reserved	24'b0

7:6	R/W	RXTRIG[1:0]	<p>Receiver Trigger Level The data ready interrupt (DR) will be asserted when the receiver buffer depth is equal to the number of characters programmed in the trigger register. The trigger level encoding is as follows:</p> <table border="1"> <thead> <tr> <th>RXTRIG</th> <th>Trigger Level</th> </tr> </thead> <tbody> <tr> <td>0</td> <td>1</td> </tr> <tr> <td>1</td> <td>4</td> </tr> <tr> <td>2</td> <td>8</td> </tr> <tr> <td>3</td> <td>14</td> </tr> </tbody> </table> <p>Note: This register is not used if the receive FIFO is disabled.</p>	RXTRIG	Trigger Level	0	1	1	4	2	8	3	14	2'b0
RXTRIG	Trigger Level													
0	1													
1	4													
2	8													
3	14													
5:4	R/W	TXTRIG[1:0]	<p>Transmitter Trigger Level The THRE interrupt will be asserted if the transmitter buffer depth is less than or equal to the number of characters programmed in the trigger register. The trigger level encoding is as follows:</p> <table border="1"> <thead> <tr> <th>TXTRIG</th> <th>Trigger Level</th> </tr> </thead> <tbody> <tr> <td>0</td> <td>1</td> </tr> <tr> <td>1</td> <td>4</td> </tr> <tr> <td>2</td> <td>8</td> </tr> <tr> <td>3</td> <td>12</td> </tr> </tbody> </table>	TXTRIG	Trigger Level	0	1	1	4	2	8	3	12	2'b0
TXTRIG	Trigger Level													
0	1													
1	4													
2	8													
3	12													
3	R/W	DMAMODE	<p>Enable DMA transfers This bit is writeable and readable, but has no other hardware function.</p>	1'b0										
2	W	TXRST	<p>Transmitter Reset Writing a '1' to this bit will clear the transmit FIFO and reset the transmitter status. The shift register is not cleared.</p>	1'b0										
1	W	RXRST	<p>Receive Reset Writing a '1' to this bit will clear the receive FIFO and reset the receiver status. The shift register is not cleared.</p>	1'b0										
0	R/W	FIFOENA	<p>0: The Transmit and Receive FIFOs have the effective depth of one character. 1: The Transmit and Receive FIFOs are enabled. Note: The FIFO status and data are automatically cleared when this bit is changed.</p>	1'b0										

LCR: Line Control Register (offset: 0x 14, 0x00000000, 0xfffff00, 00)

Bits	Type	Name	Description	Initial value
31:8	-	-	Reserved	24'b0
7	R/W	DLAB	<p>Divisor Latch Access Bit This bit has no functionality, and is retained for compatibility only</p>	2'b0
6	R/W	SETBRK	<p>Set Break Condition 0: Normal functionality. 1: Force TXD pin to '0'. Transmitter otherwise operates normally.</p>	2'b0
5	R/W	FORCEPAR	<p>Force Parity Bit 0: Normal functionality. 1: If even parity is selected, the (transmitted and checked) parity is forced to '0'; if odd parity is selected, the (transmitted and checked) parity if forced to '1'.</p>	1'b0
4	R/W	EPS	<p>Even Parity Select 0: Odd parity selected (checksum, including parity is '1'). 1: Even parity selected (checksum, including parity is '0').</p>	1'b0

			Note: This bit is ignored if the PEN bit is '0'.	
3	R/W	PEN	Parity Enable 0: Parity is not transmitted or checked. 1: Parity is generated (transmit), and checked (receive).	1'b0
2	R/W	STB	Stop Bit Select 0: 1 stop bit is transmitted and received. 1: 1.5 stop bits are transmitted and received if WLS is '0'; 2 stop bits are transmitted and received if WLS is '1', '2', or '3'.	1'b0
1:0:	R/W	WLS[1:0]	Word Length Select 0: Each character is 5 bits in length 1: Each character is 6 bits in length 2: Each character is 7 bits in length 3: Each character is 8 bits in length	2'b0

MCR: Modem Control Register (offset: 0x18)

Bits	Type	Name	Description	Initial value												
31:5	-	-	Reserved	24'b0												
4	R/W	LOOP	Loop-back Mode Enable 0: Normal Operation. 1: The UART is put into loop-back mode, used for self-test: The TXD pin is driven high; the TXD signal connections are made internally <table border="1" data-bbox="662 952 1189 1153"> <thead> <tr> <th>Signal</th> <th>Wrapped back through...</th> </tr> </thead> <tbody> <tr> <td>TXD</td> <td>RXD</td> </tr> <tr> <td>DTRN</td> <td>DSRN</td> </tr> <tr> <td>RTSN</td> <td>CTSN</td> </tr> <tr> <td>OUT1N</td> <td>RIN</td> </tr> <tr> <td>OUT2N</td> <td>DCDN</td> </tr> </tbody> </table>	Signal	Wrapped back through...	TXD	RXD	DTRN	DSRN	RTSN	CTSN	OUT1N	RIN	OUT2N	DCDN	1'b0
Signal	Wrapped back through...															
TXD	RXD															
DTRN	DSRN															
RTSN	CTSN															
OUT1N	RIN															
OUT2N	DCDN															
3	R/W	OUT2	Out2 Value 0: OUT2N pin is driven to a high level. 1: OUT2N pin is driven to a low level. Note: This bit is only functional in loop-back mode.	0												
2	R/W	OUT1	Out1 Value 0: OUT1N pin is driven to a high level. 1: OUT1N pin is driven to a low level. Note: This bit is only functional in loop-back mode.	0												
1	R/W	RTS	Out1 Value 0: RTSN pin is driven to a high level. 1: RTSN pin is driven to a low level.	1'b0												
0	R/W	DTR	Reserved 0: DTRN pin is driven to a high level. 1: DTRN pin is driven to a low level.	1'b0												

LSR: Line Status Register (offset: 0x1C)

Bits	Type	Name	Description	Initial value
31:8	-	-	Reserved	24'b0
7	R/C	ERINFIFO	The FIFO contains data which had a parity or framing error This bit is set when the FIFO contains data that was received with a parity error, framing error or break condition.	1'b0
6	R/C	TEMT	Transmitter Empty This bit is set when the transmitter shift register is empty; it will clear as soon as data is written to the TBR register.	1'b0
5	R/C	THRE	Transmitter Holding Register Empty This bit is set when the transmitter holding register is empty; it will clear as soon as data is written to the TBR register.	1'b0
4	R/C	BI	Break Interrupt	1'b0

			This bit is set if a break is received, that is when the RXD signal is at a low state for more than one character transmission time (from start bit to stop bit). Under this condition, a single 'zero' is received.	
3	R/C	FE	Framing Error This bit is set if a valid stop bit is not detected. If a framing error occurs, the receiver will attempt to re-synchronize by sampling the Start Bit twice and then takes the data.	1'b0
2	R/C	PE	Parity Error This bit is set if the received parity is different from the expected value.	1'b0
1	R/C	OE	Overrun Error This bit is set when a receive overrun occurs. This will happen if a character is received before the previous character has been read by firmware.	1'b0
0	R/C	DR	Data Ready This bit is set when a character is received, and has been transferred in to the receiver buffer register. This bit will reset when all the characters are read from the receiver buffer register.	1'b0

MSR: Modem Status Register (offset: 0x20)

Bits	Type	Name	Description	Initial value
31:8	-	-	Reserved	24'b0
7	R/C	DCD	Data Carrier Detect This bit is set when the DCDN (Data Carrier Detect) pin is at a low value.	1'b0
6	R/C	RI	Ring Indicator This bit is set when the RIN (Ring Indicator) pin is at a low value.	1'b0
5	R/C	DSR	Data Set Ready This bit is set when the DSRN (Data Set Ready) pin is at a low value.	1'b0
4	R/C	CTS	Clear to Send This bit is set when the CTSN (Clear to Send) pin is at a low value.	1'b0
3	R/C	DDCD	Delta Data Carrier Detect This bit is set when the DCDN (Data Carrier Detect) pin changes.	1'b0
2	R/C	TERI	Trailing Edge Ring Indicator This bit is set when the RIN (Ring Indicator) pin changes from a low to a high value.	1'b0
1	R/C	DDSR	Delta Data Set Ready This bit is set when the DSRN (Data Set Ready) pin changes.	1'b0
0	R/C	DCTS	Delta Clear to Send This bit is set when the CTSN (Clear to Send) pin changes.	1'b0

SCRATCH: Scratch Register (offset: 0x24)

Bits	Type	Name	Description	Initial value
31:8	-	-	Reserved	24'b0
7:0	R/W	SCRATCH[7:0]	Scratch This register is defined as a scratch register in 16550 applications. It has no hardware function, and is retained for compatibility only.	8'b0

DL: Clock Divider Divisor Latch (offset: 0x28)

Bits	Type	Name	Description	Initial value
31:16	-	-	Reserved	16'b0
15:0	R/W	DL[15:0]	Divisor Latch This register is used in the clock divider to generate the baud clock. The baud rate (transfer rate in bits per second) is defined as: $\text{Baud rate} = \text{system clock frequency} / (\text{CLKDIV} * 16).$ Note: In a standard 16550 implementation, this register is accessible as two 8-bit halves only. In this implementation, the DL register is accessible as a single 16-bit entity only.	16'h0001

DLLO: Clock Divider Divisor Latch Low (offset: 0x2C)

Bits	Type	Name	Description	Initial value
31:8	-	-	Reserved	24'b0
7:0	R/W	DLLO[7:0]	This register is the equivalent to the lower 8 bits of the DL register. It is provided for 16550 compatibility. Note: In a standard 16550 implementation, this register is accessible as two 8-bit halves only. For convenience, the divisor latch is accessible as a single 16-bit entity via the DL register.	8'b1

DLHI: Clock Divider Divisor Latch High (offset: 0x30)

Bits	Type	Name	Description	Initial value
31:8	-	-	Reserved	24'b0
7:0	R/W	DLHI[7:0]	This register is the equivalent to the upper 8 bits of the DL register. It is provided for 16550 compatibility. Note: In a standard 16550 implementation, this register is accessible as two 8-bit halves only. For convenience, the divisor latch is accessible as a single 16-bit entity via the DL register.	8'b0

3.8 UART Lite

3.8.1 Features

- 2-pin UART
- 16550-compatible register set, except for the Divisor Latch register
- 5-8 data bits
- 1-2 stop bits (1 or 2 stop bits are supported with 5 data bits)
- Even, odd, stick or no parity
- All standard baud rates from 40 b/s to 2.5 Mb/s
- 16-byte receive buffer
- 16-byte transmit buffer
- Receive buffer threshold interrupt
- Transmit buffer threshold interrupt
- False start bit detection in asynchronous mode
- Internal diagnostic capabilities
- Break simulation
- Loop-back control for communications link fault isolation

3.8.2 Block Diagram

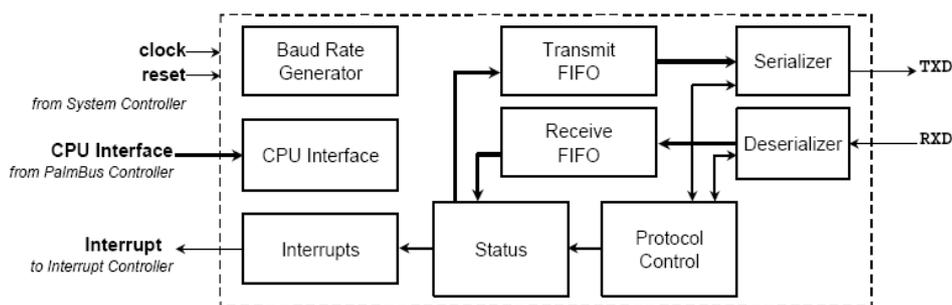

Fig. 3-8-1 UART Lite Block Diagram

3.8.3 Register Description (base: 0x1000.0C00)

RBR: Receive Buffer Register (offset: 0x00)

Bits	Type	Name	Description	Initial value
31:8	-	-	Reserved	24'b0
7:0	RO	RXD[7:0]	Receive Buffer Data Receive data. Data is transferred to this register from the receive shift register after a full character is received. The OE bit in the LSR register is set, indication a receive buffer overrun, if the contents of this register has not been read before another character is received.	8'b0

TBR: Transmit Buffer Register (offset: 0x04)

Bits	Type	Name	Description	Initial value
31:8	-	-	Reserved	24'b0
7:0	RO	TXD[7:0]	Transmit Buffer Data Transmit data. When a character is written to this register, it is stored in the transmitter holding register; if the transmitter register is empty, the character is moved to the transmitter register, starting transmission.	8'b0

IER: Interrupt Enable Register (offset: 0x08)

Bits	Type	Name	Description	Initial value
31:3	-	-	Reserved	29'b0
2	R/W	ELSI	Enable Receiver Line Status Interrupt 1: Enable line status (OE, PE, FE, and BI) interrupts. 0: Disable line status (OE, PE, FE, and BI) interrupts.	1'b0
1	R/W	ETBEI	Enable Transmitter Buffer Line Status Interrupt 1: Enable transmit buffer empty (THRE) interrupt. 0: Disable transmit buffer empty (THRE) interrupt.	1'b0
0	R/W	ERBFI	Enable Receiver Buffer Empty Interrupt 1: Enable data ready (DR) or character time-out interrupt. 0: Disable data ready (DR) or character time-out interrupt.	1'b0

IIR: Interrupt Identification Register (offset: 0x0C)

Bits	Type	Name	Description	Initial value																																				
31:8	-	-	Reserved	24'b0																																				
7:6	RO	FIFOENA [1:0]	FIFOs Enabled FIFOs Enabled. These bits reflect the FIFO enable bit setting in the FIFO Control Register. When the FIFO enable bit is set, both of these bits will be set high to a value of '11'. When the FIFO enable bit is cleared, both of these bits will be set low to a value of '00'.	1'b0																																				
5:4	-	-	Reserved	2'b0																																				
3:1	RO	INTID[2:0]	<p>Interrupt Identifier Interrupt ID. These bits provide a snapshot of the interrupt type, and may be used as the offset into an interrupt vector table. The interrupt encoding is given below.</p> <table border="1"> <thead> <tr> <th>ID</th> <th>Priority</th> <th>Type</th> <th>Source</th> </tr> </thead> <tbody> <tr> <td>7</td> <td></td> <td>Undefined</td> <td></td> </tr> <tr> <td>6</td> <td></td> <td>Undefined</td> <td></td> </tr> <tr> <td>5</td> <td></td> <td>Undefined</td> <td></td> </tr> <tr> <td>4</td> <td></td> <td>Undefined</td> <td></td> </tr> <tr> <td>3</td> <td>1</td> <td>Receiver Line Status</td> <td>OE,PE,FE,BI</td> </tr> <tr> <td>2</td> <td>2</td> <td>Receiver Buffer Full</td> <td>DR</td> </tr> <tr> <td>1</td> <td>3</td> <td>Transmit buffer Empty</td> <td>THRE</td> </tr> <tr> <td>0</td> <td>4</td> <td>Modem Status</td> <td>DCTD,DDSR, RI, DCD</td> </tr> </tbody> </table> <p>If more than one category of interrupt is asserted, only the highest priority ID will be given. The line and Modem status interrupts are cleared by reading the corresponding status register (LSR, MSR). The Receive Buffer Full interrupt will be cleared when all of the data is read from the receiver buffer. The Transmitter Buffer empty will be cleared when data is written to the TBR register. See also "Interrupt Priorities".</p>	ID	Priority	Type	Source	7		Undefined		6		Undefined		5		Undefined		4		Undefined		3	1	Receiver Line Status	OE,PE,FE,BI	2	2	Receiver Buffer Full	DR	1	3	Transmit buffer Empty	THRE	0	4	Modem Status	DCTD,DDSR, RI, DCD	3'b0
ID	Priority	Type	Source																																					
7		Undefined																																						
6		Undefined																																						
5		Undefined																																						
4		Undefined																																						
3	1	Receiver Line Status	OE,PE,FE,BI																																					
2	2	Receiver Buffer Full	DR																																					
1	3	Transmit buffer Empty	THRE																																					
0	4	Modem Status	DCTD,DDSR, RI, DCD																																					
0	RO	INTPEND	Interrupt Pending 0: An interrupt bit is set and is not masked. 1: No interrupts are pending.	1'b0																																				

FCR: FIFO Control Register (offset: 0x10)

Bits	Type	Name	Description	Initial value
31:8	-	-	Reserved	24'b0
7:6	R/W	RXTRIG [1:0]	Receiver Trigger Level The data ready interrupt (DR) will be asserted when the receiver buffer depth is equal to the number of characters programmed in the trigger register. The trigger level encoding is as follows:	2'b0

				RXTRIG	Trigger Level		
				0	1		
				1	4		
				2	8		
				3	14		
			Note: This register is not used if the receive FIFO is disabled.				
5:4	R/W	TXTRIG[1:0]	Transmitter Trigger Level The THRE interrupt will be asserted if the transmitter buffer depth is less than or equal to the number of characters programmed in the trigger register. The trigger level encoding is as follows:			2'b0	
				TXTRIG	Trigger Level		
				0	1		
				1	4		
				2	8		
				3	12		
3	R/W	DMAMODE	Enable DMA transfers This bit is writeable and readable, but has no other hardware function.			1'b0	
2	W	TXRST	Transmitter Reset Writing a '1' to this bit will clear the transmit FIFO and reset the transmitter status. The shift register is not cleared.			1'b0	
1	W	RXRST	Receive Reset Writing a '1' to this bit will clear the receive FIFO and reset the receiver status. The shift register is not cleared.			1'b0	
0	R/W	FIFOENA	0: The Transmit and Receive FIFOs have the effective depth of one character. 1: The Transmit and Receive FIFOs are enabled. Note: The FIFO status and data are automatically cleared when this bit is changed.			1'b0	

LCR: Line Control Register (offset: 0x14)

Bits	Type	Name	Description	Initial value
31:8	-	-	Reserved	24'b0
7	R/W	DLAB	Divisor Latch Access Bit This bit has no functionality, and is retained for compatibility only	2'b0
6	R/W	SETBRK	Set Break Condition 0: Normal functionality. 1: Force TXD pin to '0'. Transmitter otherwise operates normally.	2'b0
5	R/W	FORCEPAR	Force Parity Bit 0: Normal functionality. 1: If even parity is selected, the (transmitted and checked) parity is forced to '0'; if odd parity is selected, the (transmitted and checked) parity if forced to '1'.	1'b0
4	R/W	EPS	Even Parity Select 0: Odd parity selected (checksum, including parity is '1'). 1: Even parity selected (checksum, including parity is '0'). Note: This bit is ignored if the PEN bit is '0'.	1'b0
3	R/W	PEN	Parity Enable 0: Parity is not transmitted or checked. 1: Parity is generated (transmit), and checked (receive).	1'b0
2	R/W	STB	Stop Bit Select 0: 1 stop bit is transmitted and received. 1: 1.5 stop bits are transmitted and received if WLS is '0'; 2 stop bits are transmitted and received if WLS is '1', '2', or '3'.	1'b0

1:0:	R/W	WLS[1:0]	Word Length Select 0: Each character is 5 bits in length 1: Each character is 6 bits in length 2: Each character is 7 bits in length 3: Each character is 8 bits in length	2'b0
------	-----	----------	--	------

MCR: Modem Control Register (offset: 0x18)

Bits	Type	Name	Description	Initial value
31:5	-	-	Reserved	24'b0
4	R/W	LOOP	Loop-back Mode Enable 0: Normal Operation. 1: The UART is put into loop-back mode, used for self-test: The TXD pin is driven high; the TXD signal are connected to RXD internally.	1'b0
3:0	RO	-	Reserved	7'b0

LSR: Line Status Register (offset: 0x1C)

Bits	Type	Name	Description	Initial value
31:8	-	-	Reserved	24'b0
7	R/C	ERINFIFO	The FIFO contains data which had a parity or framing error This bit is set when the FIFO contains data that was received with a parity error, framing error or break condition.	2'b0
6	R/C	TEMT	Transmitter Empty This bit is set when the transmitter shift register is empty; it will clear as soon as data is written to the TBR register.	1'b0
5	R/C	THRE	Transmitter Holding Register Empty This bit is set when the transmitter holding register is empty; it will clear as soon as data is written to the TBR register.	1'b0
4	R/C	BI	Break Interrupt This bit is set if a break is received, that is when the RXD signal is at a low state for more than one character transmission time (from start bit to stop bit). Under this condition, a single 'zero' is received.	1'b0
3	R/C	FE	Framing Error This bit is set if a valid stop bit is not detected. If a framing error occurs, the receiver will attempt to re-synchronize by sampling the Start Bit twice and then takes the data.	1'b0
2	R/C	PE	Parity Error This bit is set if the received parity is different from the expected value.	1'b0
1	R/C	OE	Overrun Error This bit is set when a receive overrun occurs. This will happen if a character is received before the previous character has been read by firmware.	1'b0
0	R/C	DR	Data Ready This bit is set when a character is received, and has been transferred in to the receiver buffer register. This bit will reset when all the characters are read from the receiver buffer register.	1'b0

DL: Clock Divider Divisor Latch (offset: 0x28)

Bits	Type	Name	Description	Initial value
31:16	-	-	Reserved	16'b0
15:0	R/W	DL[15:0]	Divisor Latch This register is used in the clock divider to generate the baud clock. The baud rate (transfer rate in bits per second) is defined as: Baud rate = system clock frequency / (CLKDIV * 16).	16'h0001

			Note: In standard 16550 implementation, this register is accessible as two 8-bit halves only. In this implementation, the register is accessible as a single 16-bit entity only.	
--	--	--	--	--

DLLO: Clock Divider Divisor Latch Low (offset: 0x2C)

Bits	Type	Name	Description	Initial value
31:8	-	-	Reserved	24'b0
7:0	R/W	DLLO[7:0]	This register is the equivalent to the lower 8 bits of the DL register. It is provided for 16550 compatibility. Note: In a standard 16550 implementation, this register is accessible as two 8-bit halves only. For convenience, the divisor latch is accessible as a single 16-bit entity via the DL register.	8'b1

DLHI : Clock Divider Divisor Latch High (offset: 0x30)

Bits	Type	Name	Description	Initial value
31:8	-	-	Reserved	24'b0
7:0	R/W	DLHI[7:0]	This register is the equivalent to the upper 8 bits of the DL register. It is provided for 16550 compatibility. Note: In a standard 16550 implementation, this register is accessible as two 8-bit halves only. For convenience, the divisor latch is accessible as a single 16-bit entity via the DL register.	8'b0

IFCTL : Interface Control (offset: 0x34)

Bits	Type	Name	Description	Initial value
31:1	-	-	Reserved	31'b0
0	R/W	IFCTL	Open Collector Mode Control. This register controls if the UART Lite TXD output functions in open collector mode or is always driven. When set to '0', the output is always driven with the value of the transmit data signal. When set to a '1', the TXD output functions in open collector mode, where the TXD output is either driven low (when the transmit data output is active low) or tri-stated (when the transmit data output is active high).	1'b0

3.9 Programmable I/O

3.9.1 Features

- Support 52 programmable I/Os
- Parameterized numbers of independent inputs, outputs, and inputs
- Independent polarity controls for each pin
- Independently masked edge detect interrupt on any input transition
- Programmable I/O pins are shared pin with JTAG, UART-Lite, UART, SPI, PCM and I2C.

3.9.2 Block Diagram

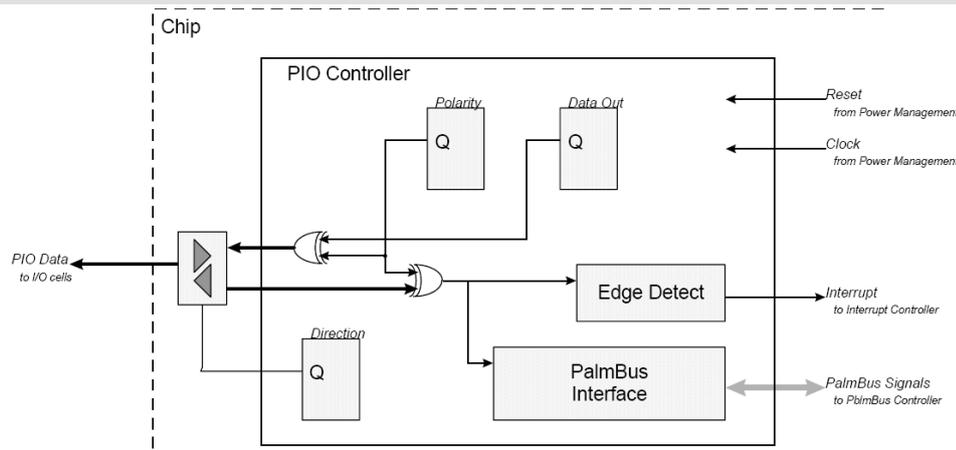

Fig. 3-9-1 Program I/O Block Diagram

3.9.3 Register Description (base: 0x1000.0600)

GPIO23_00_INT: Programmed I/O Interrupt Status (offset: 0x00)

Bits	Type	Name	Description	Initial value
31:24	-	-	Reserved	8'b0
23:0	R/C	PIOINT[23:0]	A PIOINT bit is set when its corresponding PIO pin changes value and the edge for that pin is enabled via the PIORMSK or PIOFMSK register. A pin must be set as an input in the PIODIR register to generate an interrupt. All bits are cleared by writing "1" to either this register or the PIOEDGE register. Note: Changes to the PIO pins can only be detected when the clock is running.	24'b0

GPIO23_00_EDGE: Programmed I/O Edge Status (offset: 0x04)

Bits	Type	Name	Description	Initial value
31:24	-	-	Reserved	8'b0
23:0	R/C	PIOEDGE[23:0]	The PIOEDGE bits have different meanings depending on whether the interrupt for that pin is enabled via the PIORMSK or PIOFMSK register. If the interrupt is enabled, upon getting an interrupt condition (the corresponding PIOINT bit will be set), the PIOEDGE bit will be '1' if a rising edge triggered the interrupt, or '0' if a falling edge triggered the interrupt. If the interrupt is masked (disabled), the PIOEDGE bit will be set on either a rising or falling edge and remain set until cleared by firmware. Bits corresponding to pins that are not set as inputs will never be set. All bits are cleared by writing "1" to either this register or the PIOINT register. Note: Changes to the PIO pins can only be detected when the clock is running.	24'b0

GPIO23_00_RENA: Programmed I/O Rising Edge Interrupt Enable (offset: 0x08)

Bits	Type	Name	Description	Initial value
31:24	-	-	Reserved	8'b0
23:0	R/W	PIORENA[23:0]	Rising edge mask for individual Programmed I/O pin The bits in this register enable the PIO interrupt to be set when the data on the corresponding PIO pin transitions from a '0' to a '1', i.e. a rising edge. A '1' will allow the interrupt to be set; a '0' will not allow the interrupt so that it will not be set. Note: Edge detection is done after the polarity is adjusted according to the PIOPOL register.	24'b0

GPIO23_00_FENA: Programmed I/O Falling Edge Interrupt Enable (offset: 0x0C)

Bits	Type	Name	Description	Initial value
31:24	-	-	Reserved	8'b0
23:0	R/W	PIOFMASK [23:0]	Falling edge mask for individual Programmed I/O pin The bits in this register enable the PIO interrupt to be set when the data on the corresponding PIO pin transitions from a '1' to a '0', i.e. a falling edge. A '1' will allow the interrupt to be set; a '0' will not allow the interrupt so that it will not be set. Note: Edge detection is done after the polarity is adjusted according to the PIOPOL register.	24'b0

GPIO23_00_DATA: Programmed I/O Data (offset: 0x20)

Bits	Type	Name	Description	Initial value
31:24	-	-	Reserved	8'b0
23:0	R/W	PIODATA[23:0]	Data Pin for Program I/O These bits are used for driving or sensing static signals on the PIO pins. To drive a value onto a PIO pin, the corresponding bit in the PIODIR register must be set. If the corresponding direction bit is set, the value written to the bit in the PIODATA register will be driven at the pin. A read of this register returns the value of the signals currently on the PIO pins. Note: The value of any bit in this register will be inverted with respect to the pin if the corresponding bit in the PIOPOL register is set, both in input and output modes. Note: The values read from the PIO pins are not synchronized; the user should be sure that the data will not be changing when this register is read, or should be aware that the bits which are not static at that time may be inaccurate.	24'b0

GPIO23_00_DIR: Programmed I/O Direction (offset: 0x24)

Bits	Type	Name	Description	Initial value
31:24	-	-	Reserved	8'b0
23:0	R/W	PIODIR[23:0]	Program I/O Pin Direction These bits are used for selecting the data direction of the PIO pins. To configure any pin as an output, the corresponding bit should be set to '1'; to configure any pin as an input, the corresponding bit should be set to '0'. The value driven onto the PIO pins, are controlled by the PIOPOL, and PIODATA registers.	24'b0

GPIO23_00_POL: Programmed I/O Pin Polarity (offset: 0x28)

Bits	Type	Name	Description	Initial value
31:24	-	-	Reserved	8'b0
23:0	R/W	PIOPOL[23:0]	Program I/O Pin Polarity These bits are used for controlling the polarity of the data driven on or read from the PIO pins. To invert the polarity of the data at any PIO pin, the corresponding bit should be set to '1'; a value of '0' will not modify the pin data. Note: The polarity controls affect both input and output modes.	24'b0

GPIO23_00_SET: Set PIO Data Bit (offset: 0x2C)

Bits	Type	Name	Description	Initial value
31:24	-	-	Reserved	8'b0
23:0	R/C	PIOSET[23:0]	These bits are used for setting bits in the PIODATA output register. Writing a '1' will set the corresponding bit in the PIODATA register. Writing a '0' will have no effect.	24'b0

GPIO23_00_RESET: Clear PIO Data bit (offset: 0x30)

Bits	Type	Name	Description	Initial value
31:24	-	-	Reserved	8'b0
23:0	R/C	PIORESET[23:0]	These bits are used for clearing bits in the PIODATA output register. Writing a '1' will clear the corresponding bit in the PIODATA register. Writing a '0' will have no effect.	24'b0

GPIO23_00_TOG: Toggle PIO Data bit (offset: 0x34)

Bits	Type	Name	Description	Initial value
31:24	-	-	Reserved	8'b0
23:0	R/C	PIOTOG[23:0]	These bits are used for toggling bits in the PIODATA output register. Writing a '1' will invert the corresponding bit in the PIODATA register. Writing a '0' will have no effect.	24'b0

GPIO39_24_INT : Program I/O Interrupt (offset: 0x38)

Bits	Type	Name	Description	Initial value
31:16	-	-	Reserved	16'b0
15:0	R/C	PIOINT[15:0]	A PIOINT bit is set when its corresponding PIO pin changes value and the edge for that pin is enabled via the PIORMSK or PIOFMSK register. A pin must be set as an input in the PIODIR register to generate an interrupt. All bits are cleared by writing "1" to either this register or the PIOEDGE register. Note: Changes to the PIO pins can only be detected when the clock is running.	16'b0

GPIO39_24_EDGE : Program I/O Edge Status (offset: 0x3c)

Bits	Type	Name	Description	Initial value
31:16	-	-	Reserved	16'b0
15:0	R/C	PIOEDGE [15:0]	The PIOEDGE bits have different meanings depending on whether the interrupt for that pin is enabled via the PIORMSK or PIOFMSK register. If the interrupt is enabled, upon getting an interrupt condition (the corresponding PIOINT bit will be set), the PIOEDGE bit will be '1' if a rising edge triggered the interrupt, or '0' if a falling edge triggered the interrupt. If the interrupt is masked (disabled), the PIOEDGE bit will be set on either a rising or falling edge and remain set until cleared by firmware. Bits corresponding to pins that are not set as inputs will never be set. All bits are cleared by writing "1" to either this register or the PIOINT register. Note: Changes to the PIO pins can only be detected when the clock is running.	16'b0

GPIO39_24_RENA : Program I/O Rising Edge Interrupt Enable (offset: 0x40)

Bits	Type	Name	Description	Initial value
31:16	-	-	Reserved	16'b0
15:0	R/W	PIORENA[15:0]	Rising edge mask for individual Programmed I/O pin The bits in this register enable the PIO interrupt to be set when the data on the corresponding PIO pin transitions from a '0' to a '1', i.e. a rising edge. A '1' will allow the interrupt to be set; a '0' will not allow the interrupt so that it will not be set. Note: Edge detection is done after polarity is adjusted according to the PIOPOL register.	16'b0

GPIO39_24_FENA : Program I/O Falling Edge Interrupt Enable (offset: 0x44)

Bits	Type	Name	Description	Initial value
31:16	-	-	Reserved	16'b0
15:0	R/W	PIOFENA[15:0]	<p>Falling edge mask for individual Programmed I/O pin</p> <p>The bits in this register enable the PIO interrupt to be set when the data on the corresponding PIO pin transitions from a '1' to a '0', i.e. a falling edge. A '1' will allow the interrupt to be set; a '0' will not allow the interrupt so that it will not be set.</p> <p>Note: Edge detection is done after polarity is adjusted according to the PIOPOL register.</p>	16'b0

GPIO39_24_DATA : Program I/O Data (offset: 0x48)

Bits	Type	Name	Description	Initial value
31:16	-	-	Reserved	16'b0
15:0	R/W	PIODATA[15:0]	<p>Data Pin for Program I/O</p> <p>These bits are used for driving or sensing static signals on the PIO pins. To drive a value onto a PIO pin, the corresponding bit in the PIODIR register must be set. If the corresponding direction bit is set, the value written to the bit in the PIODATA register will be driven at the pin. A read of this register returns the value of the signals currently on the PIO pins.</p> <p>Note: The value of any bit in this register will be inverted with respect to the pin if the corresponding bit in the PIOPOL register is set, both in input and output modes.</p> <p>Note: The values read from the PIO pins are not synchronized; the user should be sure that the data will not be changing when this register is read, or should be aware that the bits which are not static at that time may be inaccurate.</p>	16'b0

GPIO39_24_DIR : Program I/O Direction (offset: 0x4c)

Bits	Type	Name	Description	Initial value
31:16	-	-	Reserved	16'b0
15:0	R/W	PIODIR[15:0]	<p>Program I/O Pin Direction</p> <p>These bits are used for selecting the data direction of the PIO pins. To configure any pin as an output, the corresponding bit should be set to '1'; to configure any pin as an input, the corresponding bit should be set to '0'. The value driven onto the PIO pins, are controlled by the PIOPOL, and PIODATA registers.</p>	16'b0

GPIO39_24_POL : Program I/O Pin Polarity (offset: 0x50)

Bits	Type	Name	Description	Initial value
31:16	-	-	Reserved	16'b0
15:0	R/W	PIOPOL[15:0]	<p>Program I/O Pin Polarity</p> <p>These bits are used for controlling the polarity of the data driven on or read from the PIO pins. To invert the polarity of the data at any PIO pin, the corresponding bit should be set to '1'; a value of '0' will not modify the pin data.</p> <p>Note: The polarity controls affect both input and output modes.</p>	16'b0

GPIO39_24_SET : Set PIO Data Bit (offset: 0x54)

Bits	Type	Name	Description	Initial value
31:16	-	-	Reserved	16'b0
15:0	R/C	PIOSET[15:0]	<p>These bits are used for clearing bits in the PIODATA output register. Writing a '1' will clear the corresponding bit in the PIODATA register. Writing a '0' will have no effect.</p>	16'b0

GPIO39_24_RESET : Clear PIO Data bit [39:24] (offset: 0x58)

Bits	Type	Name	Description	Initial value
31:16	-	-	Reserved	16'b0
15:0	R/C	PIORESET[15:0]	These bits are used for setting bits in the PIODATA output register. Writing a '1' will set the corresponding bit in the PIODATA register. Writing a '0' will have no effect.	16'b0

GPIO39_24_TOG : Toggle PIO Data bit (offset: 0x5c)

Bits	Type	Name	Description	Initial value
31:16	-	-	Reserved	16'b0
15:0	R/C	PIOTOG[15:0]	These bits are used for toggling bits in the PIODATA output register. Writing a '1' will invert the corresponding bit in the PIODATA register. Writing a '0' will have no effect.	16'b0

GPIO51_40_INT : Program I/O Interrupt Status (offset: 0x60)

Bits	Type	Name	Description	Initial value
31:12	-	-	Reserved	20'b0
11:0	R/C	PIOINT[11:0]	A PIOINT bit is set when its corresponding PIO pin changes value and the edge for that pin is enabled via the PIORMSK or PIOFMSK register. A pin must be set as an input in the PIODIR register to generate an interrupt. All bits are cleared by writing "1" to either this register or the PIOEDGE register. Note: Changes to the PIO pins can only be detected when the clock is running.	12'b0

GPIO51_40_EDGE : Program I/O Edge Status (offset: 0x64)

Bits	Type	Name	Description	Initial value
23:12	-	-	Reserved	20'b0
11:0	R/C	PIOEDGE[11:0]	The PIOEDGE bits have different meanings depending on whether the interrupt for that pin is enabled via the PIORMSK or PIOFMSK register. If the interrupt is enabled, upon getting an interrupt condition (the corresponding PIOINT bit will be set), the PIOEDGE bit will be '1' if a rising edge triggered the interrupt, or '0' if a falling edge triggered the interrupt. If the interrupt is masked (disabled), the PIOEDGE bit will be set on either a rising or falling edge and remain set until cleared by firmware. Bits corresponding to pins that are not set as inputs will never be set. All bits are cleared by writing "1" to either this register or the PIOINT register. Note: Changes to the PIO pins can only be detected when the clock is running.	12'b0

GPIO51_40_RENA : Program I/O Rising Edge Interrupt Enable (offset: 0x68)

Bits	Type	Name	Description	Initial value
23:12	-	-	Reserved	20'b0
11:0	R/W	PIORENA[11:0]	Rising edge mask for individual Programmed I/O pin The bits in this register enable the PIO interrupt to be set when the data on the corresponding PIO pin transitions from a '0' to a '1', i.e. a rising edge. A '1' will allow the interrupt to be set; a '0' will not allow the interrupt so that it will not be set. Note: Edge detection is done after polarity is adjusted according to the PIOPOL register.	12'b0

GPIO51_40_FENA : Program I/O Falling Edge Interrupt Enable (offset: 0x6C)

Bits	Type	Name	Description	Initial value
23:12	-	-	Reserved	20'b0
11:0	R/W	PIORENA[11:0]	Falling edge mask for individual Programmed I/O pin The bits in this register enable the PIO interrupt to be set when	12'b0

			<p>the data on the corresponding PIO pin transitions from a '1' to a '0', i.e. a falling edge. A '1' will allow the interrupt to be set; a '0' will not allow the interrupt so that it will not be set.</p> <p>Note: Edge detection is done after polarity is adjusted according to the PIOPOL register.</p>	
--	--	--	--	--

GPIO51_40_DATA : Program I/O Data (offset: 0x70)

Bits	Type	Name	Description	Initial value
23:12	-	-	Reserved	20'b0
11:0	R/W	PIODATA[11:0]	<p>Data Pin for Program I/O</p> <p>These bits are used for driving or sensing static signals on the PIO pins. To drive a value onto a PIO pin, the corresponding bit in the PIODIR register must be set. If the corresponding direction bit is set, the value written to the bit in the PIODATA register will be driven at the pin. A read of this register returns the value of the signals currently on the PIO pins.</p> <p>Note: The value of any bit in this register will be inverted with respect to the pin if the corresponding bit in the PIOPOL register is set, both in input and output modes.</p> <p>Note: The values read from the PIO pins are not synchronized; the user should be sure that the data will not be changing when this register is read, or should be aware that the bits which are not static at that time may be inaccurate.</p>	12'b0

GPIO51_40_DIR : Program I/O Direction (offset: 0x74)

Bits	Type	Name	Description	Initial value
23:12	-	-	Reserved	20'b0
11:0	R/W	PIODIR [11:0]	<p>Program I/O Pin Direction</p> <p>These bits are used for selecting the data direction of the PIO pins. To configure any pin as an output, the corresponding bit should be set to '1'; to configure any pin as an input, the corresponding bit should be set to '0'. The value driven onto the PIO pins, are controlled by the PIOPOL, and PIODATA registers.</p>	12'b0

GPIO51_40_POL : Program I/O Pin Polarity (offset: 0x78)

Bits	Type	Name	Description	Initial value
23:12	-	-	Reserved	20'b0
11:0	R/W	PIOPOL [11:0]	<p>Program I/O Pin Polarity</p> <p>These bits are used for controlling the polarity of the data driven on or read from the PIO pins. To invert the polarity of the data at any PIO pin, the corresponding bit should be set to '1'; a value will not modify the pin data.</p> <p>Note: The polarity controls affect both input and output modes.</p>	12'b0

GPIO51_40_SET : Set PIO Data Bit (offset: 0x7C)

Bits	Type	Name	Description	Initial value
23:12	-	-	Reserved	20'b0
11:0	R/C	PIOSET [11:0]	<p>These bits are used for clearing bits in the PIODATA output register. Writing a '1' will clear the corresponding bit in the PIODATA register. Writing a '0' will have no effect.</p>	12'b0

GPIO51_40_RESET : Clear PIO Data bit (offset: 0x80)

Bits	Type	Name	Description	Initial value
23:12	-	-	Reserved	20'b0
11:0	R/C	PIORESET [11:0]	<p>These bits are used for setting bits in the PIODATA output register. Writing a '1' will set the corresponding bit in the PIODATA register. Writing a '0' will have no effect.</p>	12'b0

GPIO51_40_TOG : Toggle PIO Data bit (offset: 0x84)

Bits	Type	Name	Description	Initial value
23:12	-	-	Reserved	20'b0
11:0	R/C	PIOTOG [11:0]	These bits are used for toggling bits in the PIODATA output register. Writing a '1' will invert the corresponding bit in the PIODATA register. Writing a '0' will have no effect.	12'b0

3.10 I2C Controller

3.10.1 Features

- Two I2C Host Controllers
- Programmable I2C bus clock rate
- Supports the Synchronous Inter Integrated Circuits (I2C) serial protocol
- Bi-directional data transfer
- Programmable address width up to 8 bits
- Sequential byte read or write capability
- Device address and data address can be transmitted for device, page and address selection
- Supports Standard mode and Fast mode

3.10.2 Block Diagram

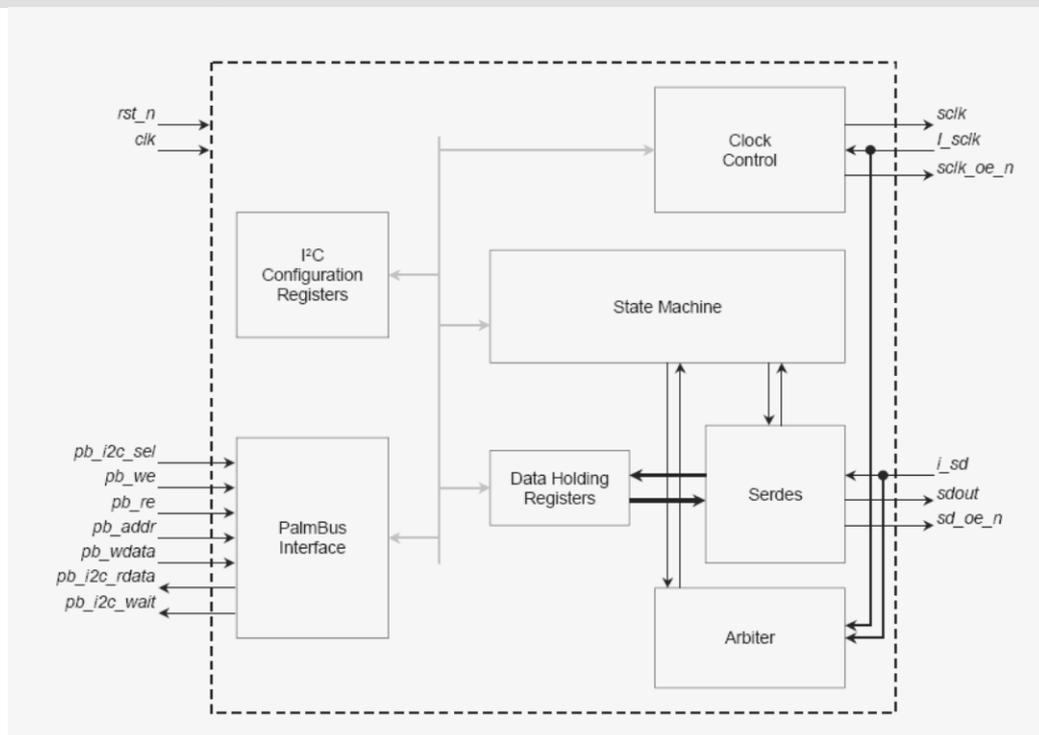

Fig. 3-10-1 I2C controller Block Diagram

3.10.3 Register Description (base: 0x1000.0900)

CONFIG: I2C Configuration Register (offset: 0x00)

Bits	Type	Name	Description	Initial value
31:8	-	-	Reserved	24'b0
7:5	R/W	ADDRLLEN [2:0]	Address Length The value written to this register plus one will indicate the number of address bits to be transferred from the I2C ADDR register. Program '0' for a 1-bit address, '1' for a 2-bit address, etc.)	3'b0
4:2	R/W	DEVADLEN [2:0]	Device Address Length The value written to this register plus one indicates the number of device address bits to be transferred from the DEVADDR register. This field should be programmed to '6' for compliance with I2C bus protocol.	3'b0

1	R/W	ADDRDIS	0: Normal transfers will occur with the address being Transmitted, followed by read or write data. 1: The controller will read or write serial data without transferring the address.	1'b0
0	R/W	DEVADDIS	0: The device address will be transmitted before the data address. 1: The controller will not transfer the device address. Note: if this bit is set, the ADDRDIS bit is ignored, and an address is always transmitted. Note: most I2C slave devices require a device address to be transmitted; this bit should typically be set to '0'.	1'b0

CLKDIV: I2C Clock Divisor Register (offset: 0x04)

Bits	Type	Name	Description	Initial value
31:16	-	-	Reserved	16'b0
15:0	R/W	CLKDIV[15:0]	Clock Divisor The value written to this register is used to generate the I2C bus SCLK signal by applying the following equation: SCLK frequency = system_clk frequency / (2 x CLKDIV) Note: system_clk frequency = 1/3 CPU clock frequency Note: Only values of 8 and above are valid. Note: Due to synchronization between the I2C internal clock and the system clock, the exact equation is actually SCLK frequency = system_clk frequency / ((2 x CLKDIV) + 5). For most systems, CLKDIV is usually programmed to very larger numbers since the system clock frequency should be orders of magnitude faster than the I2C bus clock. These results in the synchronization errors being insignificant and the exact equation approximating the simpler one given above.	16'b0

DEVADDR: I2C Device Address Register (offset: 0x08)

Bits	Type	Name	Description	Initial value
31:7	-	-	Reserved	25'b0
6:0	R/W	DEVADDR[6:0]	I2C Device Address This value is transmitted as the device address, if DEVADDIS bit in the CONFIG register is not set to '1'.	7'b0

ADDR: I2C Address Register (offset: 0x0c)

Bits	Type	Name	Description	Initial value
31:8	-	-	Reserved	24'b0
7:0	R/W	ADDR[7:0]	I2C Address These bits store the 8-bits of address to be sent to the external I2C slave devices when the ADDRDIS bit is '0'.	8'b0

DATAOUT: I2C Data Out Register (offset: 0x10)

Bits	Type	Name	Description	Initial value
31:8	-	-	Reserved	24'b0
7:0	R/W	DATAOUT [7:0]	I2C Data Out These bits store the 8-bits of data to be written to the external I2C slave devices during a write transfer.	8'b0

DATAIN: I2C Data In Register (offset: 0x14)

Bits	Type	Name	Description	Initial value
31:8	-	-	Reserved	24'b0
7:0	RO	DATAIN[7:0]	I2C Data In These bits store the 8-bits of data received from the external I2C slave devices during a read transaction. The DATARDY bit in the STATUS register is set to '1' when data is valid in this register.	8'b0

STATUS: I2C Status Register (offset: 0x18)

Bits	Type	Name	Description	Initial value
31:5	-	-	Reserved	27'b0
4	RO	STARTERR	Start Overflow Error This bit is set when the STARTXFR register is written and a transfer is in progress. When this occurs, the write to the STARTXFR register is ignored. This bit is automatically cleared if firmware writes to the STARTXFR register when the BUSY bit cleared.	1'b0
3	RO	ACKERR	I2C Acknowledge Error Detect This bit is set when the Host controller did not receive a proper acknowledge from the I2C slave device after the transmission of a device address, address, or data out. This bit is automatically cleared when firmware writes to the STARTXFR register.	1'b0
2	RO	DATARDY	I2C Data Ready for Read This bit indicates that the receive buffer contains valid data. It is set when data is received from an I2C slave device and is transferred from the interface shift register to the DATAIN register. This bit is automatically cleared when firmware reads the DATAIN register.	1'b0
1	RO	SDOEMPTY	I2C Serial Data Out Register Empty This bit indicates that the transmit data buffer is empty. It is cleared when the DATAOUT register is written to by software, and set to '1' when transmit data is transferred from the DATAOUT register to the interface shift register. Firmware may write to the DATAOUT register when this bit is '1'.	1'b1
0	RO	BUSY	I2C State Machine Busy This bit is '1' when the I2C interface is active and '0' when it is idle. Firmware may initiate an I2C transfer when this bit is '0', and should not modify any I2C host controller registers while it is '1'.	1'b0

STARTXFR: I2C Transfer Start Register (offset: 0x1C)

Bits	Type	Name	Description	Initial value
31:2	-	-	Reserved	30'b0
1	R/W	NODATA	Initiate transfer without transferring data When this register is written with this bit set, an address-only transaction is initiated. If DEVADDIS is '0', the device address, direction, address and stop condition are transmitted to the I2C slave device. If DEVADDIS is '1', the address and stop condition are transmitted to the I2C slave device. This bit should be written with a '0' for normal I2C bus accesses. Note: ADDRDIS is ignored if this bit is set for a transaction.	1'b0
0	R/W	RWDIR	Read/Write Direction When this register is written with this bit set, a read transaction is initiated; when written with this bit reset, a write transaction is initiated. Note: this bit is shifted out to the I2C slave device after the device address; if DEVADDIS is '1', this bit is not shifted out to the device.	1'b0

BYTECNT: I2C Byte Counter Register (offset: 0x20)

Bits	Type	Name	Description	Initial value
31:6	-	-	Reserved	26'b0

5:0	R/W	BYTCNT[5:0]	Byte Count used for sequential reads/writes The value written to this register plus one indicates the number of data bytes to be written to or read from the external I2C slave device. If its value is non-zero, multiple sequential read or write cycles will be issued with a single address (and/or device address).	6'b0
-----	-----	-------------	---	------

Ralink Confidential for ASEC

3.11 SPI Controller

3.11.1 Features

- Supports SPI master operations
- Programmable clock polarity
- Programmable interface clock rate
- Programmable bit ordering
- Firmware-controlled SPI enable
- Programmable payload (address + data) length

3.11.2 Block Diagram

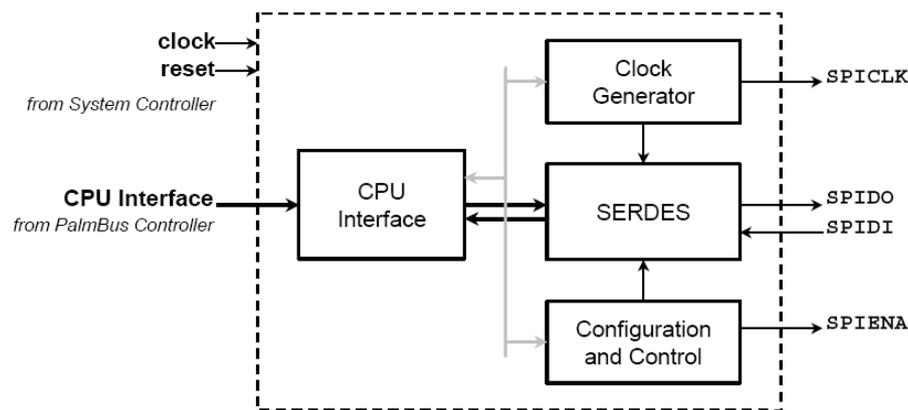

Fig. 3-11-1 SPI controller Block Diagram

3.11.3 Register Description (base: 0x1000.0B00)

SPISTAT: SPI Interface Status (offset: 0x00)

Bits	Type	Name	Description	Initial value
31:2	-	-	Reserved	30'b0
0	RO	BUSY	SPI transfer in progress 0: The SPI interface is inactive. 1: An SPI transfer is in progress. Note: This bit must be '0' before initiating a transfer. Any attempt to start a data transfer will be ignored if this bit is a '1'.	1'b0

SPICFG: SPI Interface Configuration (offset: 0x10)

Bits	Type	Name	Description	Initial value
31:9	-	-	Reserved	23'b0
8	R/W	MSBFIRST	Bit transfer order 0: LSB bits of data sent/received first. 1: MSB bits of data sent/received first. Note: This bit applies to both the command and data.	1'b1
7	-	-	Reserved	1'b0
6	R/W	SPICLKPOL	SPI clock default state 0: The default state of the SPICLK is logic '0'. 1: The default state of the SPICLK is logic '1'.	1'b0
5	R/W	RXCKEDGE	SPI clock default state 0: Data is captured on the rising edge of the SPICLK signal. 1: Data is captured on the falling edge of the SPICLK signal.	1'b0
4	R/W	TXCKEDGE	SPI clock default state 0: Data is transmitted on the rising edge of the SPICLK signal. 1: Data is transmitted on the falling edge of the SPICLK signal.	1'b0

3	R/W	HIZSPI	Tri-state all SPI pin 0: SPICLK and SPIENA pin are driven. 1: SPICLK and SPIENA pin are tri-stated. Note: This bit overrides all normal functionality.	1'b0
2:0	R/W	SPICLK[2:0]	SPI clock divide control (the rate in following table should be change in the future) 0: SPICLK rate is system clock rate / 2 1: SPICLK rate is system clock rate / 4 2: SPICLK rate is system clock rate / 8 3: SPICLK rate is system clock rate / 16 4: SPICLK rate is system clock rate / 32 5: SPICLK rate is system clock rate / 64 6: SPICLK rate is system clock rate / 128 7: SPICLK is disabled	3'b0

SPICTL: SPI Interface Control (offset: 0x14)

Bits	Type	Name	Description	Initial value
31:4	-	-	Reserved	28'b0
3	R/W	HIZSDO	Tri-state data out 0: The SPIDO pin remains driven after the cycle is complete. 1: The SPIDO pin is tri-stated after the cycle is complete. Note: This bit applies to write transfers only; for read transfers the SPIDO pin is tri-stated during the transfer.	1'b0
2	W	STARTWR	Start SPI write transfer When this bit is written with a '1', the contents of the SPIDATA register are transferred to the SPI slave device. Writing a '0' to this register has no effect. Note: The BUSY bit in the SPISTAT register is set when this bit is set and is cleared when the data transfer is complete. This bit is only meaningful if the SPI interface block is configured as a master.	1'b0
1	W	STARTRD	When this bit is written with a '1', a read from the SPI slave is started; the read data is placed in the SPIDATA register. Writing a '0' to this register has no effect. Note: The BUSY bit in the SPISTAT register is set when a this bit is set and is cleared when the data transfer is complete. This bit is only meaningful if the SPI interface block is configured as a master.	1'b0
0	R/W	SPIENA	0: The SPIENA pin is negated. 1: The SPIENA pin is asserted.	1'b0

SPIDATA: SPI Interface Data (offset: 0x20)

Bits	Type	Name	Description	Initial value
31:8	-	-	Reserved	24'b0
7:0	R/W	SPIDATA[7:0]	This register is used for command/data transfers on the SPI interface. The use of this register is given below: Write: the bits to be transferred are written here, including both command and data bits. If values are transmitted MSB (most significant bit) first, the command is placed in the upper bits and the data in the lower bits. Bit 0 of the data is written to SPIDATA [0]; bit 0 of the command follows the MSB of the data. If data is transmitted LSB (least significant bit) first, the command is placed in the lower bits and the data is placed in the upper bits. Read: the command bits are written here. Bit 0 of the command	8'b0

			is written to SPIDATA[0]. When the transfer is complete, the data transferred from the slave may be read from the lower bits of this register.	
--	--	--	--	--

Ralink Confidential for ASEC

3.12 Generic DMA Controller

3.12.1 Features

- Support 8 DMA channels
- Support 8 DMA requests
- Programmable hardware channel priority
- Programmable DMA Burst Size (1,2,4,8,16 burst transfer)
- Support 32 bit wide transaction
- Big-endian and Little-endian support
- Support memory to memory, memory to peripheral, peripheral to memory, peripheral to peripheral transfers.
- Interrupts for each channel. They also can be masked, independently.
- Each channel transaction can be masked temporarily by the software, and released by the hardware automatically.

3.12.2 Block Diagram

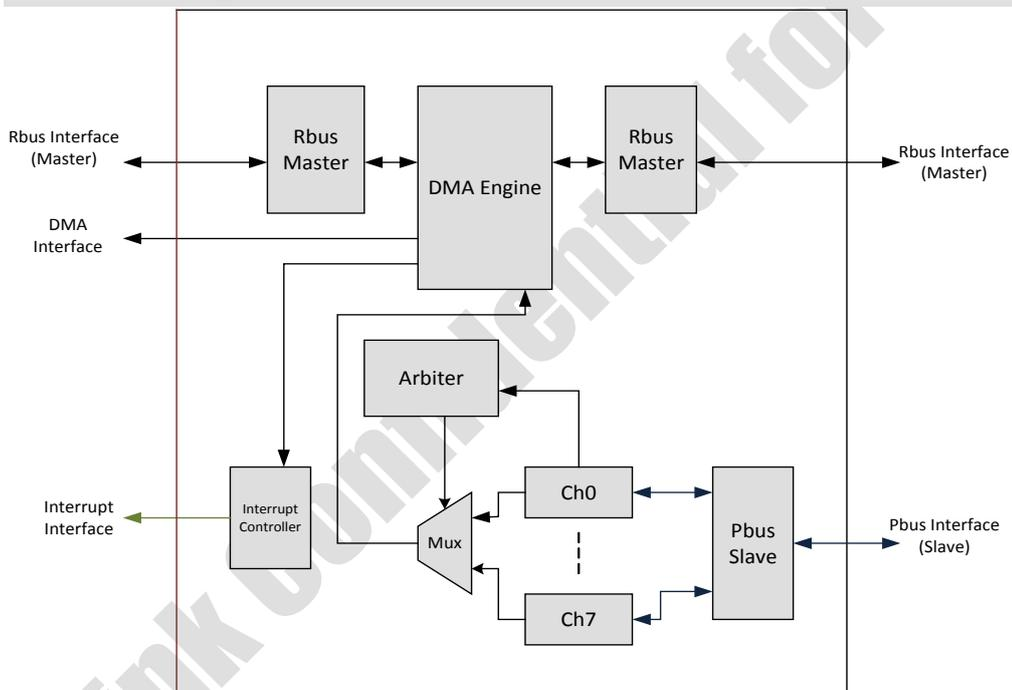

Fig. 3-12-1 Generic DMA controller Block Diagram

3.12.3 Register Description (base: 0x10000700)

GDMASn: GDMA Channel n Source Address (offset: 0x00, 0x10, 0x20, 0x30, 0x40, 0x50, 0x60, 0x70) (n:0~7)

Bits	Type	Name	Description	Initial value
31:0	R/W	CHANNEL SOURCE ADDRESS	Channel Source Address: This register contains the source address information	32'b0

GDMADAn: GDMA Channel n Destination Address (offset: 0x04, 0x14, 0x24, 0x34, 0x44, 0x54, 0x64, 0x74) (n:0~7)

Bits	Type	Name	Description	Initial value
31:0	R/W	CHANNEL DESTINATION ADDRESS	Channel Destination Address: This register contains the destination address information	32'b0

GDMACT0n: GDMA Channel n Control Register 0 (offset: 0x08, 0x18, 0x28, 0x38, 0x48, 0x58, 0x68, 0x78)

Bits	Type	Name	Description	Initial value
31:16	R/W	Transfer Count	These registers contain the number of the data bytes needed to be transfer.	12'b0
15:12	R/W	Source DMA Request	The value represents the source DMA request. 'b0000: DMA_REQ0 'b0001: DMA_REQ1 (NAND-flash) 'b0010: DMA_REQ2 (I2S) 'b0011: DMA_REQ3 (PCM0-RX) 'b0100: DMA_REQ4 (PCM1-RX) 'b0101: DMA_REQ5 (PCM0-TX) 'b0110: DMA_REQ6 (PCM1-TX) 'b0111: DMA_REQ7 'b1000: The source of the transfer is memory	4'b0
11:8	R/W	Destination DMA Request	The value represents the destination DMA request. 'b0000: DMA_REQ0 'b0001: DMA_REQ1 (NAND-flash) 'b0010: DMA_REQ2 (I2S) 'b0011: DMA_REQ3 (PCM0-RX) 'b0100: DMA_REQ4 (PCM1-RX) 'b0101: DMA_REQ5 (PCM0-TX) 'b0110: DMA_REQ6 (PCM1-TX) 'b0111: DMA_REQ7 'b1000: The destination of the transfer is memory	4'b0
7	R/W	Source Burst Mode	The value represents the source burst mode 'b0: incremental mode 'b1: fix mode	1'b0
6	R/W	Destination Burst Mode	The value represents the destination burst mode 'b0: incremental mode 'b1: fix mode	1'b0
5:3	R/W	Burst Size	The number of the transfer for burst transaction. 'b000: 1 transfer 'b001: 2 transfer 'b010: 4 transfer 'b011: 8 transfer 'b100: 16 transfer others: undefined	3'b0
2	R/W	Transmit Done Interrupt Enable	Transmit done interrupt enable. 'b1: Enable 'b0: Disable	1'b0
1	R/W	Channel Enable	Enable the channel 'b1: Enable 'b0: Disable This bit will be de-asserted by the hardware when the transaction is done.	1'b0
0	R/W	Hardware/Softw are Mode Select	Hardware/Software Mode Select 'b1: Software Mode 'b0: Hardware Mode In software mode, the data transfer will start when the Channel Enable bit is set. In hardware mode, the data transfer will start when the DMA Request is asserted.	1'b0

GDMACT1n: GDMA Channel n Control Register 1 (offset: 0x0C, 0x1C, 0x2C, 0x3C, 0x4C, 0x5C, 0x6C, 0x7C)

Bits	Type	Name	Description	Initial value
31:5	--	-	Reserved	--
4	R/W	Channel Unmasked Interrupt Enable	Channel unmasked interrupt enable. 'b1:Enable 'b0:Disable When this bit is set, an interrupt will be asserted when the hardware wants to clear the Channel Mask bit and the Channel Mask bit is 0 originally.	1'b0
3:1	R/W	Next Unmasked Channel	The value represents the next unmasked channel. When the transaction is done, the hardware will clear the Channel Mask bit of the next unmasked channel. 'b000: Channel 0 'b001: Channel 1 'b010: Channel 2 'b011: Channel 3 'b100: Channel 4 'b101: Channel 5 'b110: Channel 6 'b111: Channel 7 If the hardware doesn't need to clear any Channel Mask bit, these bits must be set to their own channel.	4'b0
0	R/W	Channel Mask	Channel Mask 'b1: This channel is masked 'b0: This channel is not masked When this channel mask is set, the GDMA transaction will not start until this bit is clear by the hardware.	1'b0

GDMAISTS: GDMA Interrupt Status Register (offset: 0x80)

Bits	Type	Name	Description	Initial value
31:24	-	-	Reserved	-
23:16	R/W1C	Unmasked Interrupt Status	This register contains the unmasked interrupt status. This bit will be set when the hardware wants to clear the Channel Mask bit and the Channel Mask bit is 0 originally. Bit23~bit16 is for channel 7 ~ channel 0, respectively.	8'b0
15:8	-	-	Reserved	-
7:0	R/W1C	Transmit Done Interrupt Status	This register contains the transmit-done interrupt status. Bit7~bit0 is for channel 7 ~ channel 0, respectively.	8'b0

GDMASSTS: GDMA Signal Status Register (offset: 0x84)

Bits	Type	Name	Description	Initial value
31:24	-	-	Reserved	-
23:16	R	GDMA Request Signal Status	This register contains the GDMA Request Signals status Bit7~bit0 is for GDMA_REQ7 ~ GDMA_REQ0, respectively.	8'b0
15:8	R	GDMA ACK Signal Status	This register contains the GDMA ACK signals status Bit7~bit0 is for GDMA_ACK7 ~ GDMA_ACK0, respectively.	8'b0
7:0	R	GDMA Finish Signal Status	This register contains the GDMA Finish signals status Bit7~bit0 is for GDMA_Finish7 ~ GDMA_Finish0, respectively.	8'b0

GDMAGCT: GDMA Global Control Register (offset: 0x88)

Bits	Type	Name	Description	Initial value
31:1	-	-	Reserved	-
0	R/W	Arbitration Selection	Select the channel arbitration method. 1'b0: Channel 0 has the highest priority. Channel 1~ Channel7 are round-robin. 1'b1: Channel 0 doesn't have the highest priority. Channel0~Channel7 are round-robin.	1'b0

3.13 PCM Controller

3.13.1 Features

- PCM module provides PBUS interface for register configuration and data transfer
- Two clock sources are reserved for PCM circuit. (From internal clock generator, int_pcm_clk, and from external clock source, ext_pcm_clk)
- PCM module can drive a clock out to external codec (out_clk_freq = int_pcm_clk/n, n = configurable by register, 1<=n<=64).
- 2 channels PCM are available. 4~128 slots are configurable.
- Each channel supports a-law (8-bits)/u-law (8-bits)/raw-PCM (16-bits) transfer.
- Hardware converter of a-law ↔ raw-16 and u-law ↔ raw-16 are implemented in design.
- Support long/short FSYNC.
- All signals are driven by rising edge and latched by falling edge.
- Last bit of DTX will be tri-stated on falling edge.
- Begin of slot is configurable by 10 bits registers each channel.
- 32 bytes FIFO are available for each channel

3.13.2 Block Diagram

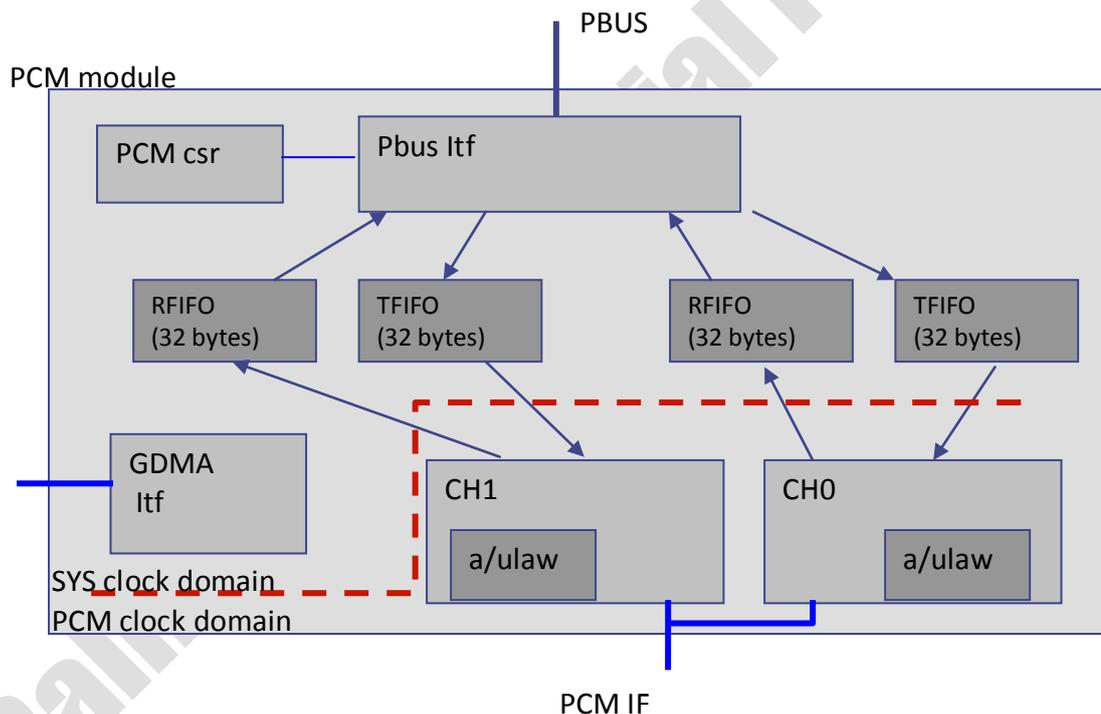

Fig. 3-13-1 PCM Controller Block Diagram

Two clocks domains are partitioned in this design. PCM converter (ulaw ↔ raw-16bit and alaw ↔ raw-16bit) are implemented in PCM mxDmx. The threshold of FIFO is configurable.

As the threshold reaches, PCM will (a) trigger the DMA interface to notify external DMA engine to transfer data, and (b) trigger the interrupts to host.

The interrupt sources include:

- threshold is reached
- FIFO under run or overrun.
- fault is detected at DMA interface.

The A-law and u-law converter is implemented base on ITU-G.711 A-law and u-law table. In this design, There is support for a-law/u-law (8-bits) ↔ linear PCM (16-bits) only. A-law ↔ u-law isn't available now.

The data-flow from codec to PCM-controller (RX-flow) is shown subsequently:

The PCM-controller latches the data from DRX at an indicated time slot and then writes it to FIFO. If FIFO is full, the data will be lost.

As the RX-FIFO reaches the threshold, two actions may be taken.

As DMA_ENA=1, DMA_REQ will be asserted to request a burst transfer: it will re-check the FIFO threshold after DMA_END is asserted by GDMA (GDMA should be configured before channel is enabled).

Assert the Interrupt source to notify HOST. HOST can check RFIFO_AVAIL information then get back the data from FIFO.

The data-flow from PCM-controller to codec (TX-flow) is shown subsequently.

After GDMA is configured, software should configure and enable the PCM channel.

The empty FIFO should.

DMA_ENA=1, DMA_REQ will be triggered to request a burst transfer. It will re-check the FIFO threshold after DMA_END is asserted by GDMA (a burst is completed.).

Assert the Interrupt source to notify HOST. HOST will write down the data to TX-FIFO. After that, HOST will recheck TFIFO_EMPTY information then write more data if available.

Note: As DMA_ENA=1, the burst size of GDMA should be less than the threshold value.

3.13.3 Register Description (base: 0x1000.0400)

GLB_CFG: GLB_CFG Register (offset: 0x00)

Bits	Type	Name	Description	Initial value
31	RW	PCM_EN	PCM enable, 1: enable 0: disable, all FSM and control register of PCM_mxDmx will be clear to default value.	0
30	RW	DMA_EN	DMA enable 1: enable DMA interface, transfer data with DMA 0: disable DMA interface, transfer data with software.	0
29:23	-	-	Reserved	0
22:20	RW	RFF_THRES	RXFIFO threshold, As threshold reach, host/dma will be notified to fill FIFO. (unit = word) It should be >2 and <6 As data in FIFO under the threshold, interrupt & DMA will be triggered.	4
19	-	-	Reserved	0
18:16	RW	TFF_THRES	TXFIFO threshold, As threshold reach, host/dma will be notified to fill FIFO. (unit = word) It should be >2 and <6. As data in FIFO over the threshold, interrupt & DMA will be triggered.	4
15:10	-	-	Reserved	0
9	RW	CH1-TX_EN	Channel-1 TX enable	0
8	RW	CH0-TX_EN	Channel-0 TX enable	0
7:2	-	-	Reserved	0
1	RW	CH1-RX_EN	Channel-1 RX enable	0
0	RW	CH0-RX_EN	Channel-0 RX enable 1: enable 0:disable	0

PCM_CFG: PCM_CFG Register (offset: 0x04)

Bits	Type	Name	Description	Initial value
31	RW	EXT_CLK_EN	PCM_CLK is generated by external source. 1: PCM_CLK is provided by external 0: PCM_CLK is generated by internal clock divider	0
30	RW	CLKOUT_EN	Enable the PCM_CLK_OUT 1: PCM_CLK_OUT should be free run 0: PCM_CLK_OUT should be pull-low forever. (NOTE: Normally, the register should be asserted to '1'. And it should be asserted after divider cfg & divider clock enable)	0
29:28	-	-	Reserved	
27	RW	EXT_FSYNC	FSYNC is provided by external. 1: FSYNC is provided by external 0: FSYNC is generated by internal circuit.	0
26	RW	LONG_FSYNC	FSYNC mode: 1: long FSYNC 0: short FSYNC	0
25	RW	FSYNC_POL	Polarity of FSYNC 1: FSYNC is high active 0: FSYNC is low active	1
24	RW	DRX_TRI	Tristate the DRX as fall edge as LSB bit. 1: Tristate the DRX 0: non- Tristate the DRX	1
23:3	-	-	Reserved	0
2:0	RW	SLOT_MODE	How many slot each PCM frame 0: 4 slots, PCM clock out/in should be 256KHz. 1: 8 slots, PCM clock out/in should be 512KHz. 2:16 slots, PCM clock out/in should be 1.024MHz. 3:32 slots, PCM clock out/in should be 2.048MHz. 4:64 slots, PCM clock out/in should be 4.096MHz. 5:128 slots, PCM clock out/in should be 8.192MHz. other: reserved. Note: When using the external clock, the frequency clock should be equal to PCM_clock out. Otherwise, the PCM_CLKin should be 8.192 MHz.	0

INT_STATUS: INT_STATUS Register (offset: 0x08)

Bits	Type	Name	Description	Initial value
31:16	RO	-	Reserved	0
15	RW	CH1T_DMA_FAULT	Found any fault of the CH1-TX's DMA signals. (Write '1' to clear)	0
14	RW	CH1T_OVRUN	The FIFO of CH1-TX overrun(Write '1' to clear)	
13	RW	CH1T_UNRUN	The FIFO of CH1-TX underrun(Write '1' to clear)	0
12	RW	CH1T_THRES	The FIFO of CH1-TX lower than the defined threshold. (Write '1' to clear)	0
11	RW	CH1R_DMA_FAULT	Found any fault of the CH1-RX's DMA signals. (Write '1' to clear)	0
10	RW	CH1R_OVRUN	The FIFO of CH1-RX overrun(Write '1' to clear)	
9	RW	CH1R_UNRUN	The FIFO of CH1-RX underrun(Write '1' to clear)	0
8	RW	CH1R_THRES	The FIFO of CH1-RX lower than the defined threshold. (Write '1' to clear)	0
7	RW	CH0T_DMA_FAULT	Found any fault of the CH0-TX's DMA signals. (Write '1' to clear)	0
6	RW	CH0T_OVRUN	The FIFO of CH0-TX overrun(Write '1' to clear)	
5	RW	CH0T_UNRUN	The FIFO of CH0-TX underrun(Write '1' to clear)	0

4	RW	CH0T_THRES	The FIFO of CH0-TX lower than the defined threshold. (Write '1' to clear)	0
3	RW	CH0R_DMA_FAULT	Found any fault of the CH0-RX's DMA signals. (Write '1' to clear)	0
2	RW	CH0R_OVRUN	The FIFO of CH0-RX overrun(Write '1' to clear)	
1	RW	CH0R_UNRUN	The FIFO of CH0-RX underrun(Write '1' to clear)	0
0	RW	CH0R_THRES	The FIFO of CH0-RX lower than the defined threshold. (Write '1' to clear)	0

INT_EN: INT_EN Register (offset: 0x0c)

Bits	Type	Name	Description	Initial value
31:16	RO	-	Reserved	0
15	RW	INT15_EN	Enable INT_STATUS[15]	0
14	RW	INT14_EN	Enable INT_STATUS[14]	0
13	RW	INT13_EN	Enable INT_STATUS[13]	0
12	RW	INT12_EN	Enable INT_STATUS[12]	0
11	RW	INT11_EN	Enable INT_STATUS[11]	0
10	RW	INT10_EN	Enable INT_STATUS[10]	0
9	RW	INT9_EN	Enable INT_STATUS[9]	0
8	RW	INT8_EN	Enable INT_STATUS[8]	0
7	RW	INT7_EN	Enable INT_STATUS[7]	0
6	RW	INT6_EN	Enable INT_STATUS[6]	0
5	RW	INT5_EN	Enable INT_STATUS[5]	0
4	RW	INT4_EN	Enable INT_STATUS[4]	0
3	RW	INT3_EN	Enable INT_STATUS[3]	0
2	RW	INT2_EN	Enable INT_STATUS[2]	0
1	RW	INT1_EN	Enable INT_STATUS[1]	0
0	RW	INT0_EN	Enable INT_STATUS[0]	0

FF_STATUS: FF_STATUS Register (offset: 0x10)

Bits	Type	Name	Description	Initial value
31:16	-	-	Reserved	0
15:12	RO	CH1RFF_AVCNT	CH1, Available FIFO space can be read (unit=word)	0
11:8	RO	CH1TFF_EPCNT	CH1, Available FIFO space can be written (unit=word)	8
7:4	RO	CH0RFF_AVCNT	CH0, Available FIFO space can be read (unit=word)	0
3:0	RO	CH0TFF_EPCNT	CH0, Available FIFO space can be written (unit=word)	8

CH0_CFG: CH0_CFG Register (offset: 0x020)

Bits	Type	Name	Description	Initial value
31	RW	LBK_EN	Loopback enable 1: loopback (Asyn-TXFIFO → DTX → DRX → Asyn-RXFIFO) 0: normal mode	0
30	RW	EXT_LBK_EN	External loopback enable 1: external loopback enable (Ext-Codec → DRX → DTX → Ext-Codec) 0: normal mode	0
29:28	RW	CMP_MODE	Compress type select 0: disable HW converter, linear raw-data (16-bits) 1: disable HW converter, A-law or U-law (8-bits) 2: enable HW converter, raw-data(16-bits) ⇔ U-law mode (8-bits) 3: enable HW converter, raw-data(16-bits) ⇔ A-law mode (8-bits)	0
27:10	-	-	Reserved	0
9:0	RW	TS_START	Timeslot Starting location	1

CH1_CFG: CH1_CFG Register (offset: 0x24)

Bits	Type	Name	Description	Initial value
31	RW	LBK_EN	Loopback enable 1: loopback (Asyn-TXFIFO→DTX→DRX→Asyn-RXFIFO) 0: normal mode	0
30	RW	EXT_LBK_EN	External loopback enable 1: external loopback enable (Ext-Codex→DRX→DTX→Ext-Codex) 0: normal mode	0
29:28	RW	CMP_MODE	Compress type select 0: disable HW converter, linear raw-data (16-bits) 1: disable HW converter, A-law or U-law (8-bits) 2: enable HW converter, raw-data(16-bits) ⇔ U-law mode (8-bits) 3: enable HW converter, raw-data(16-bits) ⇔ A-law mode (8-bits)	0
27:10	-	-	Reserved	
9:0	RW	TS_START	Timeslot Starting location	1

RSV_REG16: RSV_REG16 Register (offset: 0x30)

Bits	Type	Name	Description	Initial value
31:16	-	-	Reserved	0
15:0	RW	SPARE_REG	Spare Register for future	0

CH0_FIFO: CH0_FIFO Register (offset: 0x80)

Bits	Type	Name	Description	Initial value
31:0	RW	CH0_FIFO	FIFO access point	0

CH1_FIFO: CH1_FIFO Register (offset: 0x84)

Bits	Type	Name	Description	Initial value
31:0	RW	CH1_FIFO	FIFO access point	0

PCM initialization flow:

Step #1: Set PCM_CFG

Step #2: Set CH0/1_CFG

Step #3: Write PCM data to FIFO CH0/1_FIFO

Step #4: Set GLB_CFG to enable the PCM and channel.

Step #5: Monitor FF_STATUS to receive/transmit the other PCM data.

3.14 I2S Controller

3.14.1 Features

- I2S transmitter, which can be configured as master or slave.
- Support 16-bit data, sample rate 48Khz
- Support stereo audio data transfer.
- 32 bytes FIFO are available for data transmission.
- Support GDMA access

3.14.2 Block Diagram

The block diagram of I2S Transmitter is shown subsequently

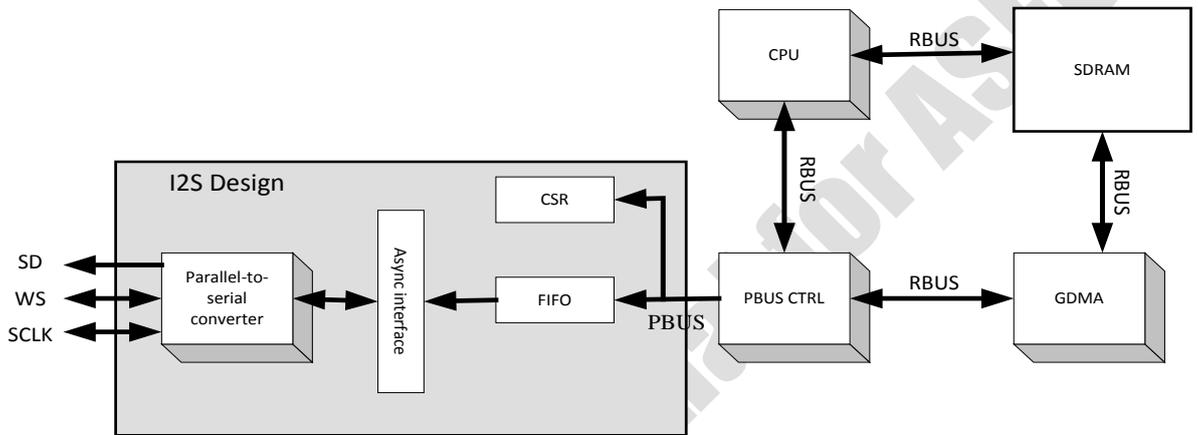

Fig. 3-14-1 I2S Transmitter Block Diagram

The I2S interface consists of two separate cores, a transmitter and a receiver. Both can operate in either master or slave mode. Here we will design only the transmitter in master or slave mode.

I2S signal timing:

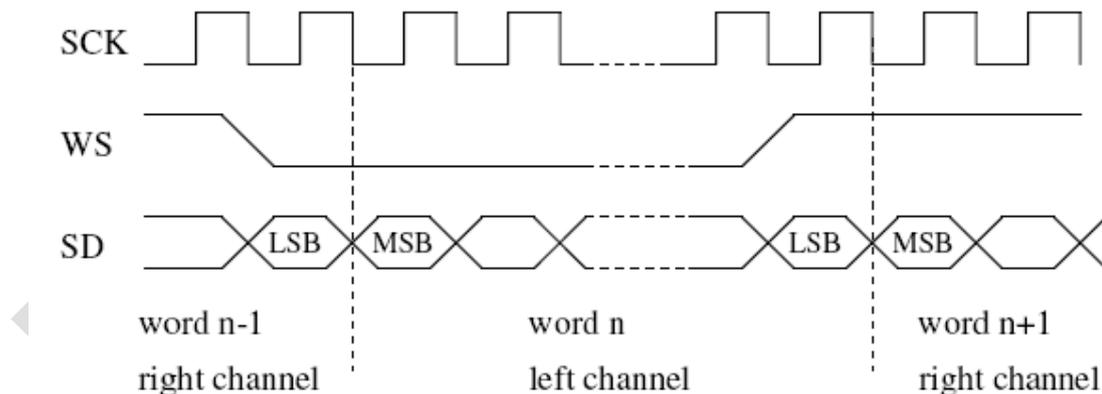

Fig. 3-14-2 I2S Transmitter

Serial data is transmitted in 2's complement with the MSB first. The transmitter always sends the MSB of the next word one clock period after the WS changes. Serial data sent by the transmitter may be synchronized with either the trailing (HIGH-to-LOW) or the leading (LOW-to-HIGH) edge of the clock signal. However, the serial data must be latched into the receiver on the leading edge of the serial clock signal, and so there are some restrictions when transmitting data that is synchronized with the leading edge.

The word select line indicates the channel being transmitted:

- WS = 0; channel 1 (left);
- WS = 1; channel 2 (right).

WS may change either on a trailing or leading edge of the serial clock, but it doesn't need to be symmetrical. In the slave, this signal is latched on the leading edge of the clock signal. The WS line changes one clock period before the MSB is transmitted. This allows the slave transmitter to derive synchronous timing of the serial data that will be set up for transmission. Furthermore, it enables the receiver to store the previous word and clear the input for the next word.

3.14.3 Register Description (base: 0x1000.0A00)

I2S_CFG: I2S Configuration Register (offset: 0x00)

Bits	Type	Name	Description	Initial value
31	RW	I2S_EN	I2S enable, 1: enable 0: disable, all control registers of I ² S will be clear to default value.	0
30	RW	DMA_EN	GDMA access enable 1: DMA enable 0: host enable	0
29:9	-	-	Reserved	
8	RW	CLK_OUT_DIS	Disable I2S clock pad to drive divider clock 1: I2S clock out pin be input PAD. 0: I2S clock out pin drive clock-signal to external Component. (NOTE: Normally, the register should be asserted to '0'. And it should be asserted after divider cfg & divider clock enable)	1
7	-	-	Reserved	0
6:4	RW	FF_THRES	FIFO threshold, As threshold reach, host/dma will notify to fill FIFO. (Unit = word) It should be >2 and <6	4
3	RW	CH_SWAP	Channel swap control 0: No swapping 1: Swap CH0 and CH1	0
2	RW	CH1_OFF	Channel 1 ON/OFF control 0: Channel 1 is ON 1: Channel 1 is OFF	0
1	RW	CH0_OFF	Channel 0 ON/OFF control 0: Channel 0 is ON 1: Channel 0 is OFF	0
0	RW	SLAVE_EN	I2S transmitter as master or slave. 1: as slave, I2S_CLK_IN is provided by external. 0: as master, I2S_CLK_IN is provided by internal circuit	0

INT_STATUS: Interrupt Status Register (offset: 0x04)

Bits	Type	Name	Description	Initial value
31:4	RO	-	Reserved	0
3	RW	DMA_FAULT	Found any fault of the GDMA signals. (Write '1' to clear)	0
2	RW	OVRUN	The FIFO is overflow (Write '1' to clear)	0
1	RW	UNRUN	The FIFO is underflow (Write '1' to clear)	0
0	RW	THRES	The FIFO is lower than the defined threshold. (Write '1' to clear)	0

INT_EN: Interrupt Enable Register (offset: 0x08)

Bits	Type	Name	Description	Initial value
31:4	RO	-	Reserved	0
3	RW	INT3_EN	Enable INT_STATUS[3]	0
2	RW	INT2_EN	Enable INT_STATUS[2]	0
1	RW	INT1_EN	Enable INT_STATUS[1]	0
0	RW	INT0_EN	Enable INT_STATUS[0]	0

FF_STATUS: FIFO Status Register (offset: 0xc)

Bits	Type	Name	Description	Initial value
31:8	-	-	Reserved	0
7:4	RO	AVCNT	Available FIFO space can be read (Unit=word)	0
3:0	RO	EPCNT	Available FIFO space can be written (Unit=word)	8

FIFO_WREG: FIFO Write Register (offset: 0x10)

Bits	Type	Name	Description	Initial value
31:0	W	FIFO_WDATA	Write data buffer	0

3.15 Memory Controller

3.15.1 Features

- Support one SDRAM(16b/32b) chip selects
- Support 2 Flash(SRAM)(8/16b) chip selects with independent timing parameters
- Support 64MB/SDRAM per chip select
- Support 32MB/Flash(SRAM) per chip select
- Support SDRAM transaction overlapping by early active and hidden pre-charge
- Support user SDRAM Init commands
- Support 4 banks per SDRAM chip select
- SDRAM burst length: 4 (fixed)
- Support Wrap-4 transfer
- Support Bank-Row-Column and Row-Bank-Column address mapping

3.15.2 Block Diagram

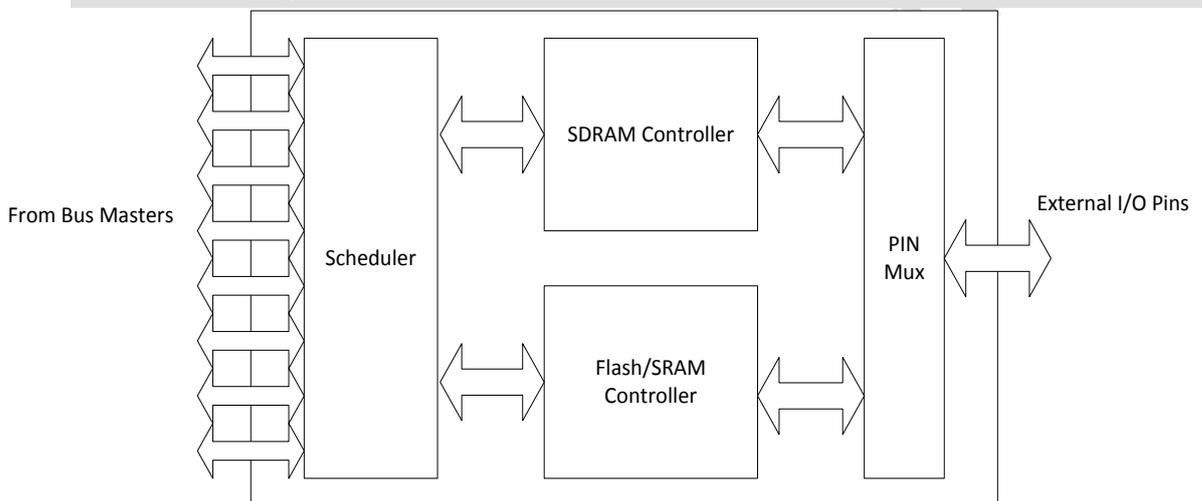

Fig. 3-15-1 Flash/SRAM/SDRAM controller Block Diagram

3.15.2.1 SDRAM Initialization Sequence

SDRAMs require an initialization sequence before they are ready for reading and writing. The initialization sequence is described below.

Step #1: setting SDRAM related timing in SDRAM_CFG0

Step#2: setting SDRAM size and refresh time in SDRAM_CFG1 register with
SDRAM_INIT_START = 1

Step#3: Read SDRAM_INIT_DONE in SDRAM_CFG1 register

Step#4: if SDRAM_INIT_DONE! =1, go to Step#3, else SDRAM initialization sequence finished

3.15.3 Register Description (base: 0x1000.0300)

SDRAM_CFG0: SDRAM Configuration 0 (offset: 0x00)

Bits	Type	Name	Description	Initial value
31	RO	ALWAYS_ONE	Use as an identification for Rbus controller	1'b1
30-29	-	-	Reserved	2'b00
28	R/W	TWR	Write Recovery time number of system clock cycles – 1.	1'b1
27:24	R/W	TMRD	LOAD MODE to any other command delay number of system clock cycles – 1.	4'b0001

23:20	R/W	TRFC	AUTO REFRESH period number of system clock cycles – 1.	4'b1001
19:18	-	-	Reserved	2'b00
17:16	R/W	TCAS	READ command to data valid delay (CAS latency) in number of system clock cycles – 1.	2'b10
15:12	R/W	TRAS	ACTIVE to PRECHARGE command delay in number of system clock cycles – 1.	4'b0101
11:10	-	-	Reserved	2'b00
9:8	R/W	TRCD	ACTIVE to READ or WRITE delay in number of system clock cycles – 1.	2'b10
7:4	R/W	TRC	ACTIVE to ACTIVE command period in number of system clock cycles -1	4'b1000
3:2	-	-	Reserved	2'b00
1:0	R/W	TRP	PRECHARGE command period in number of system clock cycles –1.	2'b10

SDRAM_CFG1: SDRAM Configuration 1 (offset: 0x04)

Bits	Type	Name	Description	Initial value
31	R/W	SDRAM_INIT_START	Write 1 to perform SDRAM initialization sequence. Cannot set it to zero after initialization.	1'b0
30	RO	SDRAM_INIT_DONE	0: SDRAM has not been initialized 1: SDRMA has been initialized	1'b0
29	R/W	RBC_MAPPING	1: {ROW ADDR, BANK ADDR, COL ADDR} address mapping scheme 0: {BANK ADDR, ROW ADDR, COL ADDR} address mapping scheme	1'b0
29:25	-	-	Reserved	5'b0
24	R/W	SDRAM_WIDTH	Number of SDRAM data bus bits: 0: 16 bits 1: 32 bits (default)	1'b1
23:22	-	-	Reserved	2'b0
21:20	R/W	NUMCOLS	Number of Column address bits: 0: 8 Column address bits 1: 9 Column address bits (default) 2: 10 Column address bits 3: 11 Column address bits	2'b01
19:18	-	-	Reserved	2'b00
17:16	R/W	NUMROWS	Number of Row address bits: 0: 11 Row address bits 1: 12 Row address bits (default) 2: 13 Row address bits 3: 14 Row address bits (not allocable if boot from NAND flash is enabled)	2'b10
15:0	R/W	TREFR	AUTO REFRESH period in number of SDRAM clock cycles – 1.	16'h0600

FLASH_CFG0: Flash Bank 0 Configuration (offset: 0x08)

Bits	Type	Name	Description	Initial value
31:28	-	-	Reserved	4'b0
27:26	RO	FLASH_WIDTH0	Number of Flash Chip Select0 data bus bits: 0: 8 bits 1: 16 bits (default) 2: reserved 3: reserved Note: This value is from boot strapping.	2'b01
25	-	-	Reserved	1'b0
24	R/W	CSADRO	Address hold time from Chip Select in number of system clock cycles	1'b1
23:22	-	-	Reserved	2'b0

21:20	R/W	TWHOLD0	Chip select and Data hold time from Write Enable in number of system clock cycles	2'b01
19:18	-	-	Reserved	2'b0
17:16	R/W	TRHOLD0	Chip select hold time from Output Enable in number of system clock cycles	2'b01
15:12	R/W	TWE0	Write Enable duration in number of system clock cycles	4'b1111
11:8	R/W	TOE0	Output Enable duration in number of system clock cycles	4'b1111
7:6	R/W	TRADR0	Read address setup in number of system clock cycles	2'b10
5:4	R/W	TWADR0	Write address setup in number of system clock cycles	2'b10
3:2	-	-	Reserved	2'b0
1:0	R/W	TADRCS0	Address setup time prior to Chip Select in number of system clock cycles	2'b01

*PS: Flash_Width0 (8/16/32 bits) is configured by power on pin capture.

Note: Total of width specified by TADRCS + TWADR/TRADR + TWE/TOE + TWHOLD/TRHOLD + TCSADR may not be fewer than 3 clock cycles.

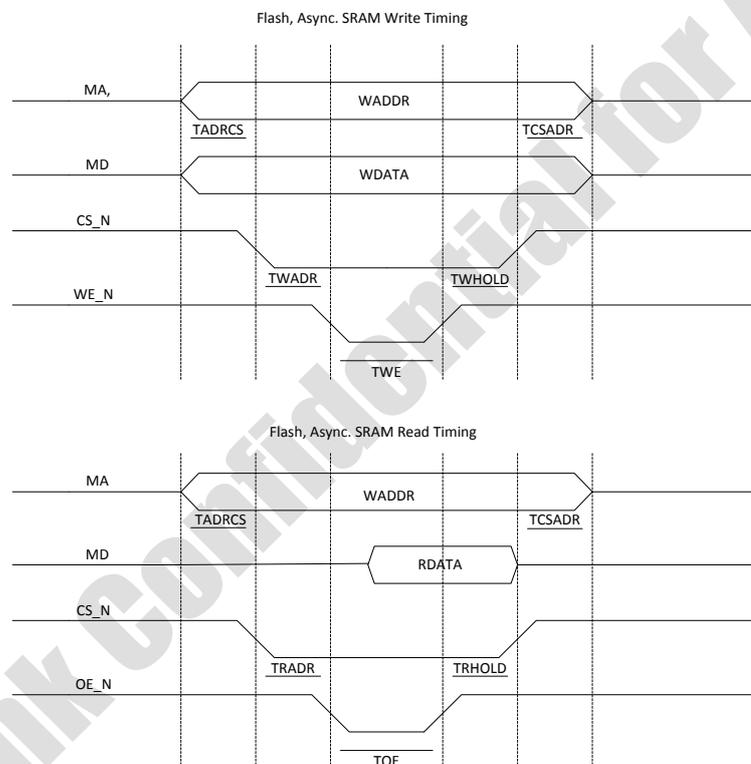

Fig. 3-15-2 Flash/SRAM/SDRAM Controller R/W waveform

Note: Total of width specified by TADRCS + TWADR/TRADR + TWE/TOE + TWHOLD/TRHOLD + TCSADR may not be fewer than 3 clock cycles

FLASH_CFG1: Flash Bank 1 Configuration (offset: 0x0C)

Bits	Type	Name	Description	Initial value
31:28	-	-	Reserved	4'b0
27:26	RW	FLASH_WIDTH1	Number of Flash Chip Select1 data bus bits: 0: 8 bits 1: 16 bits (default) 2: 32bits	2'b01
25	-	-	Reserved	1'b0
24	R/W	CSADR1	Address hold time from Chip Select in number of system clock cycles	1'b1
23:22	-	-	Reserved	2'b0

21:20	R/W	TWHOLD1	Chip select and Data hold time from Write Enable in number of system clock cycles	2'b01
19:18	-	-	Reserved	2'b0
17:16	R/W	TRHOLD10	Chip select hold time from Output Enable in number of system clock cycles	2'b01
15:12	R/W	TWE1	Write Enable duration in number of system clock cycles	4'b1111
11:8	R/W	TOE10	Output Enable duration in number of system clock cycles	4'b1111
7:6	R/W	TRADR1	Read address setup in number of system clock cycles	2'b10
5:4	R/W	TWADR1	Address setup in number of system clock cycles	2'b10
3:2	-	-	Reserved	2'b0
1:0	R/W	TADRCS1	Address setup time prior to Chip Select in number of system clock cycles	2'b01

ILL_ACC_ADDR: Illegal Access Address Capture (offset: 0x10)

Bits	Type	Name	Description	Initial value
31:0	RO	ILL_ACC_ADDR	If any bus masters (including CPU) issue illegal accesses (e.g. accessing to reserved memory space, non-double-word accessing to configuration registers), the address of the illegal transaction is captured in this register. An illegal interrupt will generate to indicate this exception.	32'b0

ILL_ACC_TYPE: Illegal Access TYPE Capture (offset: 0x14)

Bits	Type	Name	Description	Initial value
31	RO, W1C	ILL_INT_STATUS	1: Indicate the illegal access interrupt is pending 0: Indicate the illegal access interrupt is cleared Write 1 to this bit will clear both ILL_ACC_ADDR and ILL_ACC_TYPE registers and thus clear the ILL_INT_STATUS.	1'b0
30	RO	ILL_ACC_WR	Indicate the access type of the illegal access 1: illegal access is write 0: illegal access is read This value is reset to 0 when ILL_ACC_ADDR is written	1'b0
29:20	-	-	Reserved	1'b0
19:16	RO	ILL_ACC_BSEL	Indicate the byte select of the illegal access This value is reset to 0 when ILL_ACC_ADDR is written	1'b0
15:11	-	-	Reserved	1'b0
10:8	RO	ILL_IID	Indicate the initiator ID of the illegal access. 0: CPU 1: DMA 2: Ethernet PDMA 3: PPE 4: Embedded WLAN MAC/BBP 5: USB OTG 6-7: Reserved This value is reset to 0 when ILL_ACC_ADDR is written	3'b0
7:0	RO	ILL_ACC_LEN	Indicate the access size of the illegal access. The unit is byte This value is reset to 0 when ILL_ACC_ADDR is written.	8'b0

3.16 NAND Flash Controller

3.16.1 Features

- Supports boot from NAND flash memory
- Supports read / erase / page program NAND flash memory
- Hardware ECC engine. (Hardware generating and software correcting)
- The internal 4Kbytes boot buffer can be used for another application after booting
- Only supports NAND flash memory with 512-bytes page size and 8-bits data
- Indirect access for special command
- Configurable write protect register
- Little / bit ending operation

3.16.2 Block Diagram

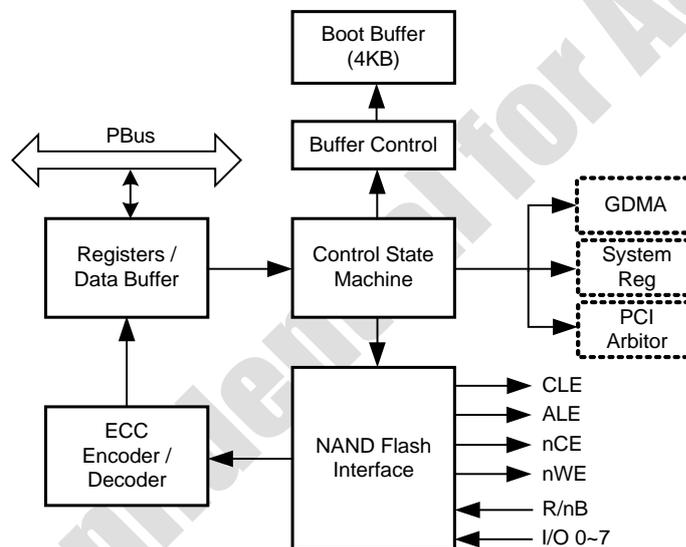

Fig. 3-16-1 NAND Flash Controller Block Diagram

3.16.3 Register Description (base: 0x1000.0800)

CTRL: NAND Flash Control Register (offset: 0x00)

Bits	Type	Name	Description	Initial value
31:24	-	-	Reserved	
23:16	RW	TWAITB	Dummy time period to wait busy signal = clock * (TWAITB+1)	0
15:12	RW	THOLD	Hold time duration = clock * (THOLD+1)	0
11:8	RW	TPERIOD	Period time duration = clock * (TPERIOD+1)	0
7:4	RW	TSETUP	Setup time duration = clock * (TSETUP+1)	0
3:2	RW	BURST_SIZE	0: 1 DW 1: 2 DW 2: 4 DW 3: 8 DW	0
1	RW	DBUF_CLR	Clear data buffer	0
0	-	-	Reserved	0

TRANS_CFG: Transfer Control Register (offset: 0x04)

Bits	Type	Name	Description	Initial value
31:30	-	-	Reserved	
29:20	RW	BNUM_DATA	Byte number of data to be transferred	528

19	-	-	Reserved	
18:16	RW	BNUM_ADDR	Byte number of address Note: maximum number is 4	3
15:14	-	-	Reserved	
13:12	RW	BNUM_CMD3	Byte number of command 3	0
11:10	RW	BNUM_CMD2	Byte number of command 2	0
9:8	RW	BNUM_CMD1	Byte number of command 1	1
7	RW	RESPB_DATA	Respect busy signal after data phase	0
6	RW	RESPB_ADDR	Respect busy signal after address phase	0
5	RW	RESPB_CMD3	Respect busy signal after command 3 phase	0
4	RW	RESPB_CMD2	Respect busy signal after command 2 phase	0
3	RW	ECC_ENA	ECC enable 0: disable 1: enable Note: In read transfer, HW ECC check function will be active. In write transfer, HW ECC generate function will be active.	0
2	RW	DMA_ENA	Issue a request to generic DMA when data read/write. 0: CPU will get/put data from/to data buffer. 1: GDMA will get/put data from/to data buffer.	0
1	RW	WR_TRANS	The transfer is read / write. 0: read 1: write	0
0	WC	KICK_TRANS	Kick the a NAND flash transfer 0: no transfer 1: kick a transfer Note: this bit will auto clear	0

CMD1: Command #1 Register (offset: 0x08)

Bits	Type	Name	Description	Initial value
31:24	-	-	Reserved	
23:16	RW	CMD1_BYTE3	3 rd byte of command 1	0
15:8	RW	CMD1_BYTE2	2 nd byte of command 1	0
7:0	RW	CMD1_BYTE1	1 st byte of command 1	0

CMD2: Command #2 Register (offset: 0x0C)

Bits	Type	Name	Description	Initial value
31:24	-	-	Reserved	
23:16	RW	CMD2_BYTE3	3 rd byte of command 2	0
15:8	RW	CMD2_BYTE2	2 nd byte of command 2	0
7:0	RW	CMD2_BYTE1	1 st byte of command 2	0

CMD3: Command #3 Register (offset: 0x10)

Bits	Type	Name	Description	Initial value
31:24	-	-	Reserved	
23:16	RW	CMD3_BYTE3	3 rd byte of command 3	0
15:8	RW	CMD3_BYTE2	2 nd byte of command 3	0
7:0	RW	CMD3_BYTE1	1 st byte of command 3	0

ADDR: Address Register (offset: 0x14)

Bits	Type	Name	Description	Initial value
31:24	RW	ADD_BYTE4	4 th byte of address	
23:16	RW	ADD_BYTE3	3 rd byte of address	0
15:8	RW	ADD_BYTE2	2 nd byte of address	0
7:0	RW	ADD_BYTE1	1 st byte of address	0

DATA: Data Register (offset: 0x18)

Bits	Type	Name	Description	Initial value
31:0	RW	DATA	Data for read / write	0

ECC_ENC: ECC Encode Register (offset: 0x1C)

Bits	Type	Name	Description	Initial value
31:24	-	-	Reserved	-
23:16	R	ENC_BYTE2	3 rd byte of ECC encode	0
15:8	R	ENC_BYTE1	2 nd byte of ECC encode	0
7:0	R	ENC_BYTE0	1 st byte of ECC encode	0

STATUS: Status Register (offset: 0x20)

Bits	Type	Name	Description	Initial value
31:17	-	-	Reserved	-
16:8	R	DEC_BYTE	ECC decode fail byte address	0
7	-	-	Reserved	-
6:4	R	DEC_BIT	ECC decode fail bit address	0
3	-	-	Reserved	-
2	R	ND_RB_N	NAND flash ready 0: busy 1: ready	1
1	R	DEC_ERR	ECC decode check status 0: no error 1: correctable error or ecc error	0
0	R	BUSY	NAND flash controller is in busy. 0: idle 1: busy	0

INT_STATUS (offset: 0x0c, default: 0x00)

Bits	Type	Name	Description	Initial value
31:8	-	-	Reserved	-
7	W1C	RX_KICK_ERR	Rx buffer not empty at host kick	0
6	W1C	TX_KICK_ERR	Tx buffer not empty at host kick	0
5	W1C	RX_TRAS_ERR	Rx buffer not empty at transfer done	0
4	W1C	TX_TRAS_ERR	Tx buffer not empty at transfer done	0
3	W1C	ECC_ERR	ECC error	0
2	W1C	RX_BUF_RDY	Rx buffer read ready	0
1	W1C	TX_BUF_RDY	Tx buffer write ready	0
0	W1C	ND_DONE	Transfer done	0

3.17 Frame Engine

3.17.1 Features

- Wire-speed (1000Mbps) Ethernet LAN/WAN NAT/NAPT routing
- L1-L7(content aware) policy table
- QoS support for multimedia traffic
- Support per flow/rule accounting/rate limiting
- Checksum/VLAN/PPPoE offload

3.17.1.1 Network Interfaces

- One Scatter-Gather packet DMA with Rbus master interface
- One special port for packet processing engine

3.17.1.2 PSE (Packet Switch Engine) Features

- Four external ports and one special PPE port (for packet bridging/routing)
- Efficient page-based buffer management
- QoS-aware queue management
- Supports 4 output queues/virtual WAN/LAN port
- WRR/Strict priority scheduling
- Egress rate limiting/shaping
- Non-blocking, wire-speed packet switching
- Flow control for no-packet-loss guarantee
- Emulated multicast support (can mirror a TX packet to CPU)
- Checksum offload, VLAN & PPPOE header insertion (by CDMA)

3.17.1.3 PPE Features

- Supports 512 policy rules for ACL, accounting and rate limiting.
 - The policy rules can base on pre-route/post-route L1-L7 headers & contents (up-to 16 bytes)
 - DDoS avoidance by rate limiting
 - Supports stateful packet filtering (SPI)
 - Supports IPv4 NAT/NAPT routing
 - Supports 1/2/4/8/16K IPv4 NAPT flows
 - Supports virtual server, port-triggering & port forwarding
 - Supports any kind of IPv4 NAT(NAPT, Twice NAT)
 - Supports 16 PPPoE sessions
 - Supports cone-NAT, port-restricted NAT & Symmetric NAT
 - Supports per rule or per flow accounting or rate limiting
 - Patent-pending Flow Offloading technology for flexible/high performance packet L3/L4 packet processing
 - Supports double VLAN tagging (Q-in-Q)
 - Support VID Swapping
 - Support multi-WAN load balancing with H/W S/W cooperation
- PS: All the PPE features mentioned above require software porting to enable.

3.17.1.4 QoS Related Features

- Packets can be classified based on L1-L7 headers/content
- Supports 4 TX queues
- Supports WRR scheduling for the two virtual WAN and LAN ports

- Supports egress rate limiting for each network port
- Powerful buffer reservation scheme to reserve packet buffer resources for multi-media traffic.

3.17.1.5 Packet DMA (PDMA) Features

- Supports 4 TX descriptor rings and one RX descriptor ring
- Scatter/Gather DMA
- Delayed interrupt
- Configurable 4/8/16 32-bit word burst length

3.17.2 Block Diagram

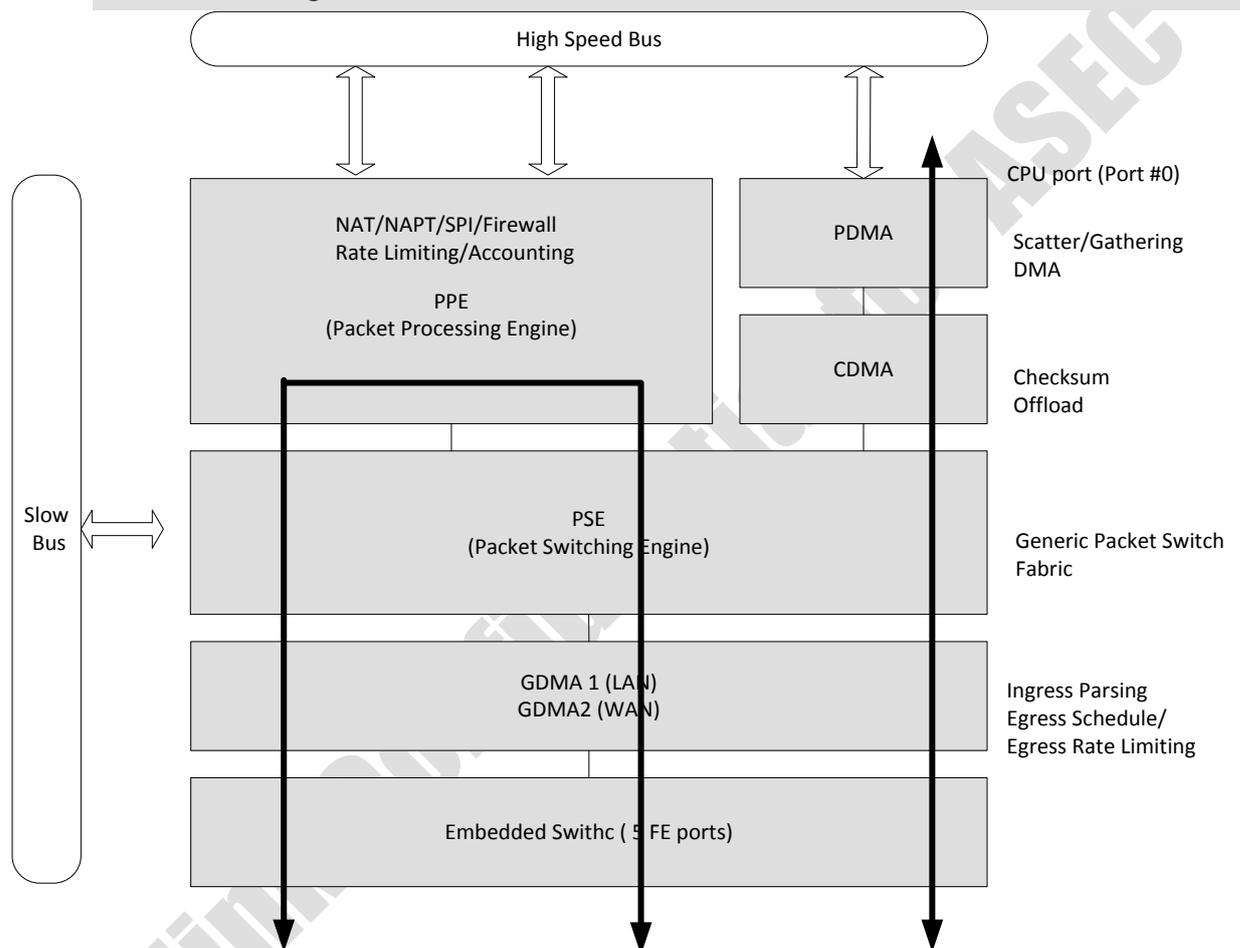
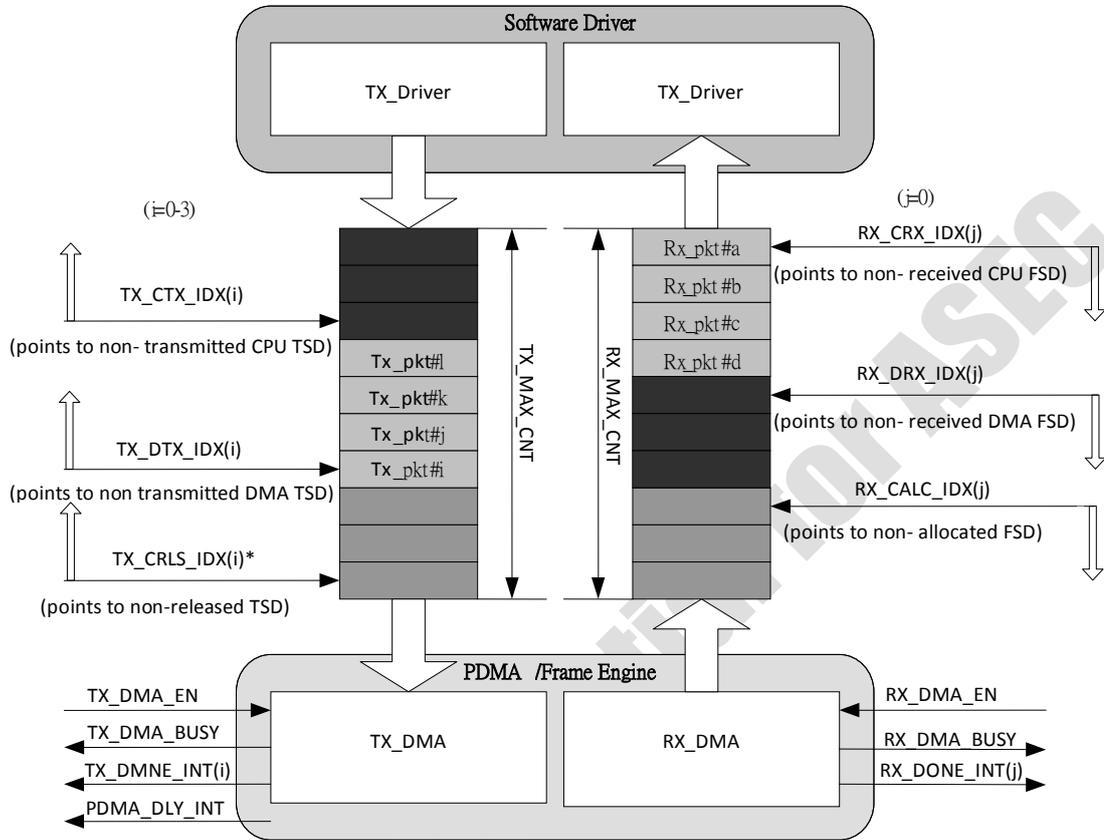

Fig. 3-17-1 Frame Engine Block Diagram

3.17.2.1 PDMA FIFO-like Ring Concept

Note1: $TX_CRLSIDX(i)$ and $RX_CRXIDX(i)$ are not in PDMA hardware they are resident in CPUs Local memory

Note2:

$TXQ0$: PDMA low queue

$RXQ0$: For PDMA receive

$TXQ1$: PDMA high queue

Fig. 3-17-2 PDMA FIFO-like Ring Concept

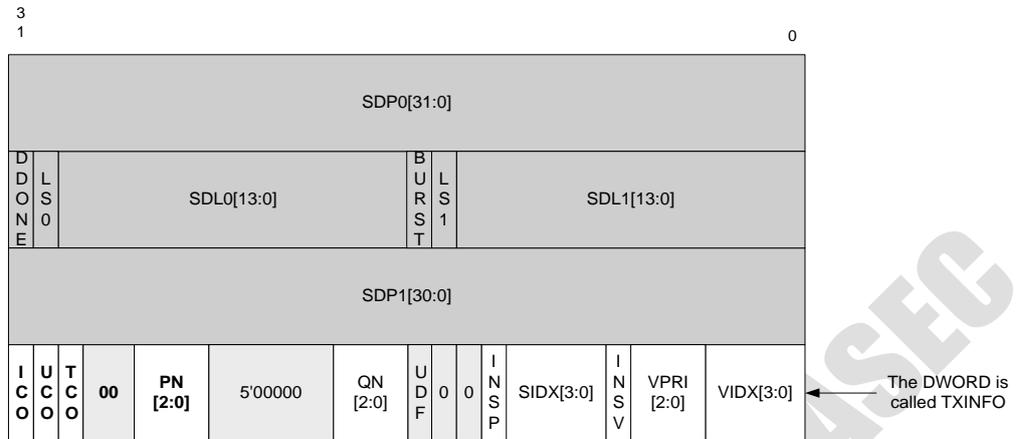
3.17.2.2 PDMA Descriptor Format

Byte 3

Byte 2

Byte 1

Byte 0

SDP : Segment Data Pointer
 SDL : Segment Data Length
 LS : Last Segment
 DDONE : DMA Done. Indicate DMA has transfer the segment pointed by this TX descriptor
 Burst : when set, the scheduler can not hand-over to other TS queues. Should go on to transmit the next packet

ICO : IP checksum offload enable
 UDP : UDP checksum offload enable
 TCO : TCP checksum offload enable
 PN : Destination port Number (0 : CPU, 1 : GDMA #1, 2: GDMA #2, 3-5 : Reserved, 6 : PPE, 7 : Discard)
 QN : Destination Queue Number
 UDF : User define field
 INSP : Insert PPPoE header
 SIDX : PPPoE Session index
 INSV : Insert VLAN tag
 VPRI : VLAN priority tag to be inserted
 VIDX : VLAN ID Index

Fig. 3-17-3 PDMA TX Descriptor Format

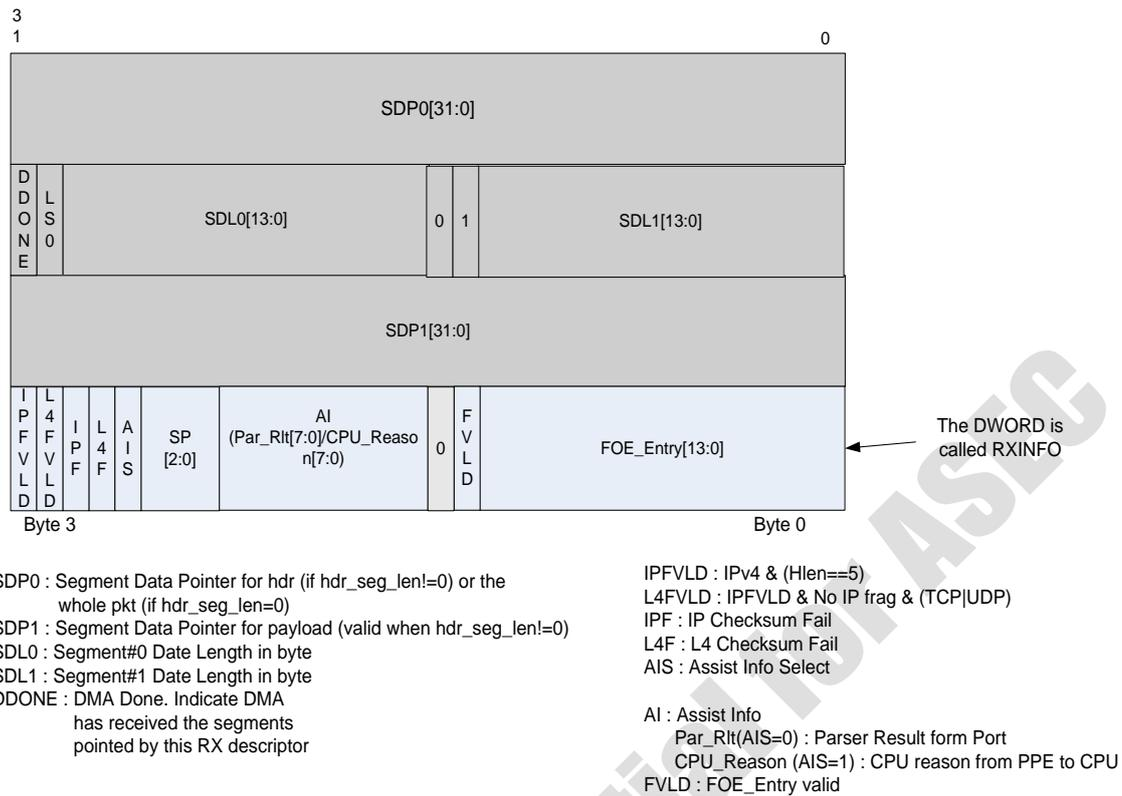

Fig. 3-17-4 PDMA RX Descriptor Format

3.17.3 Register Description (base: 0x1010.0000)

3.17.3.1 Register Description -GDMA Port (base: 0x1010.0000)

MDIO_ACCES: Reserved (offset: 0x00)

MDIO_CFG1 : Reserved (offset: 0x04)

FE_GLO_CFG: Frame Engine Global Configuration (offset: 0x08)

Bits	Type	Name	Description	Initial value
31:16	R/W	EXT_VLAN	Extended VLAN type	16'h8100
15:8	R/W	US_CYC_CNT	1us timer count in unit of clock cycle. For example, if frame engine is running at 133MHz, set this register to 8'd132.	8'd132
7:4	R/W	L2_SPACE	L2 space. Unit is 8 bytes	4'h8
3:0	-	-	Reserved	1'b0

FE_RST_GLO: Frame Engine Global Reset (offset: 0x0C)

Bits	Type	Name	Description	Initial value
31:16	RC	FC_DROP_CNT	Flow control drop packet count.	16'b0
15:1	-	-	Reserved	15'b0
0	WO	PSE_RESET	PSE reset Write 1 to reset PSE Write 0 to disable reset PSE	1'b0

FE_INT_STATUS: Frame Engine Interrupt Status (offset: 0x10)

Bits	Type	Name	Description	Initial value
31	R/W	CNT_PPE_AF	PPE Counter Table Almost Full Write 1 to clear the interrupt. Read to get the raw interrupt status	1'b0
30	-	-	Reserved	1'b0
29	R/W	CNT_GDM_AF	GDMA 1 & 2 Counter Table Almost Full Write 1 to clear the interrupt. Read to get the raw interrupt status	1'b0

28:25	-	-	Reserved	4'b0
26	R/W	PSE_P2_FC	PSE port2 (GDMA 2) flow control asserted. Write 1 to clear the interrupt. Read to get the raw interrupt status	1'b0
25	R/W	GDM_CRC_DROP	GDMA 1 & 2 discard a packet due to CRC error Write 1 to clear the interrupt. Read to get the raw interrupt status	1'b0
24	R/W	PSE_BUF_DROP	PSE discards a packet due to buffer sharing limitation (flow control) Write 1 to clear the interrupt. Read to get the raw interrupt status	1'b0
23	R/W	GDM_OTHER_DROP	GDMA 1 & 2 discard a packet due to other reason (e.g. too short, too long, FIFO overflow, checksum error,..., etc.) Write 1 to clear the interrupt. Read to get the raw interrupt status	1'b0
22	R/W	PSE_P1_FC	PSE port1 (GDMA 1) flow control asserted. Write 1 to clear the interrupt. Read to get the raw interrupt status	1'b0
21	R/W	PSE_P0_FC	PSE port0 (CDMA) flow control asserted. Write 1 to clear the interrupt. Read to get the raw interrupt status	1'b0
20	R/W	PSE_FQ_EMPTY	PSE free Q empty threshold reached & forced drop condition occurred. Write 1 to clear the interrupt. Read to get the raw interrupt status	1'b0
17	R/W	TX_COHERENT	TX_DMA finds data coherent event when checking ddone bit. Write 1 to clear the interrupt. Read to get the raw interrupt status	1'b0
16	R/W	RX_COHERENT	RX_DMA finds data coherent event when checking ddone bit. Write 1 to clear the interrupt. Read to get the raw interrupt status	1'b0
15:12	-	-	Reserved	4'b0
11	R/W	TX_DONE_INT3	Tx queue#3 packet transmit interrupt Write 1 to clear the interrupt. Read to get the raw interrupt status	1'b0
10	R/W	TX_DONE_INT2	Tx queue#2 packet transmit interrupt Write 1 to clear the interrupt. Read to get the raw interrupt status	1'b0
9	R/W	TX_DONE_INT1	Tx queue#1 packet transmit interrupt Write 1 to clear the interrupt. Read to get the raw interrupt status	1'b0
8	R/W	TX_DONE_INT0	Tx queue#0 packet transmit interrupt Write 1 to clear the interrupt. Read to get the raw interrupt status	1'b0
7:3	-	-	Reserved	5'b0
2	R/W	RX_DONE_INT0	Packet receive interrupt. Write 1 to clear the interrupt. Read to get the raw interrupt status	1'b0
1	R/W	TX_DLY_INT	Delayed version of TX_DONE_INT0 and TX_DONE_INT1. Write 1 to clear the interrupt. Read to get the raw interrupt status	1'b0
0	R/W	RX_DLY_INT	Delayed version of RX_DONE_INT0. Write 1 to clear the interrupt. Read to get the raw interrupt status	1'b0

FE_INT_ENABLE: Frame Engine Interrupt Enable (offset: 0x14)

Bits	Type	Name	Description	Initial value
31	R/W	CNT_PPE_AF	PPE Counter Table Almost Full	1'b0

			1: Enable the interrupt 0: Disable the interrupt	
30	-	-	Reserved	1'b0
29	R/W	CNT_GDM_AF	GDMA 1 & 2 Counter Table Almost Full Write 1 to clear the interrupt. Read to get the raw interrupt status	1'b0
28:27	-	-	Reserved	2'b0
26	R/W	PSE_P2_FC	PSE port2 (GDMA2) flow control asserted. 1: Enable the interrupt 0: Disable the interrupt	1'b0
25	-	-	Reserved	1'b0
24	R/W	PSE_BUF_DROP	PSE discards a packet due to buffer sharing limitation (flow control) 1: Enable the interrupt 0: Disable the interrupt	1'b0
23	R/W	GDM_OTHER_DROP	GDMA 1 & 2 discard a packet due to other reason (e.g. too short, too long, FIFO overflow, checksum error,..., etc.) 1: Enable the interrupt 0: Disable the interrupt	1'b0
22	R/W	PSE_P1_FC	PSE port1 (GDMA1) flow control asserted. 1: Enable the interrupt 0: Disable the interrupt	1'b0
21	R/W	PSE_P0_FC	PSE port0 (CDMA) flow control asserted. 1: Enable the interrupt 0: Disable the interrupt	1'b0
20	R/W	PSE_FQ_EMPTY	PSE free Q empty threshold reached & forced drop condition occurred. 1: Enable the interrupt 0: Disable the interrupt	1'b0
19-18	-	-	Reserved	2'b0
17	R/W	TX_COHERENT	TX_DMA finds data coherent event when checking ddone bit. 1: Enable the interrupt 0: Disable the interrupt	1'b0
16	R/W	RX_COHERENT	RX_DMA finds data coherent event when checking ddone bit. 1: Enable the interrupt 0: Disable the interrupt	1'b0
15:12	-	-	Reserved	4'b0
11	R/W	TX_DONE_INT3	Tx queue#3 packet transmit interrupt 1: Enable the interrupt 0: Disable the interrupt	1'b0
10	R/W	TX_DONE_INT2	Tx queue#2 packet transmit interrupt 1: Enable the interrupt 0: Disable the interrupt	1'b0
9	R/W	TX_DONE_INT1	Tx queue#1 packet transmit interrupt 1: Enable the interrupt 0: Disable the interrupt	1'b0
8	R/W	TX_DONE_INT0	Tx queue#0 packet transmit interrupt 1: Enable the interrupt 0: Disable the interrupt	1'b0
7:3	-	-	Reserved	5'b0
2	R/W	RX_DONE_INT0	Packet receives interrupt. 1: Enable the interrupt 0: Disable the interrupt	1'b0
1	R/W	TX_DLY_INT	Delayed version of TX_DONE_INT0 and 1: Enable the interrupt 0: Disable the interrupt	1'b0

0	R/W	RX_DLY_INT	Delayed version of RX_DONE_INT0. 1: Enable the interrupt 0: Disable the interrupt	1'b0
---	-----	------------	---	------

MDIO_CFG2 : Reserved (offset: 0x18)

FOE_TS_T: Time Stamp (offset: 0x1C)

Bits	Type	Name	Description	Initial value
31:24	R	PSE_FQ_PCNT	PSE free Q page count	8'hff
23:16	-	-	Reserved	8'b0
15:0	R/W	FOE_TS_T	Time stamp Note: Time Stamp unit is 1 sec.	16'b0

3.17.3.2 Register Description – GDMA 1 & 2 (base: 0x1010.0020)

GDMA_FWD_CFG: GDMA Forwarding Configuration (offset: 0x00)

Bits	Type	Name	Description	Initial value
31:25	-	-	Reserved	8'b0
24	R/W	GDM1_TCI_81xx	0: Check VLAN tag with EXT_VLAN[15:0] 1: Check VLAN tag with EXT_VLAN[15:8] only	1'b0
23	R/W	GDM_DROP_256B	A Special mode to drop packets with payload > 256 bytes. 0: Drop packets according to standard Ethernet frame length limitation. 1: Drop packets with payload >256 bytes	1'b0
22	R/W	GDM_ICS_EN	IPv4 header checksum check enable	1'b1
21	R/W	GDM_TCS_EN	TCP checksum check enable	1'b1
20	R/W	GDM_UCS_EN	UDP checksum check enable	1'b1
19	R/W	GDM1_JMB_EN	0: Drop received frames if length is great than 1518 (1522 for VLAN frames, and 1526 for double VLAN frames) 1: Allow receiving jumbo frames length up to 12kB.	1'b0
18	R/W	GDM_DISPAD	0: Enable GDMA 1 & 2 Tx padding function. 1: Disable GDMA 1 & 2 Tx padding function.	1'b0
17	R/W	GDM_DISCRC	0: Enable GDMA 1 & 2 Tx CRC generation. 1: Disable GDMA 1 & 2 Tx CRC generation.	1'b0
16	R/W	GDM_STRPCRC	0: Disable GDMA 1 & 2 automatic Rx CRC stripping 1: Enable GDMA 1 & 2 automatic Rx CRC stripping	1'b1
15	-	-	Reserved	1'b0
14:12	R/W	GDM_UFRC_P	GDMA1 & 2 My MAC uni-cast frames destination port 3'd0: CPU 3'd1: GDMA1 3'd2: GDMA2 3'd6: PPE 3'd7: Discard Others: Reserved	3'b111
11	-	-	Reserved	1'b0
10:8	R/W	GDM_BFRC_P	GDMA1 & 2 broadcast MAC address frames destination port 3'd0: CPU 3'd1: GDMA1 3'd2: GDMA2 3'd6: PPE 3'd7: Discard Others: Reserved	3'b111
7	-	-	Reserved	1'b0

6:4	R/W	GDM_MFRC_P	GDMA1 & 2 multi-cast MAC address frames destination port 3'd0: CPU 3'd1: GDMA1 3'd2: GDMA2 3'd6: PPE 3'd7: Discard Others: Reserved	3'b111
3	-	-	Reserved	1'b0
2:0	R/W	GDM_OFRC_P	GDMA1 & 2 other MAC address frames destination port 3'd0: CPU 3'd1: GDMA1 3'd2: GDMA2 3'd6: PPE 3'd7: Discard Others: Reserved	3'b111

GDMA1_SCH_CFG: GDMA1 Scheduling Configuration (offset: 0x04)

Bits	Type	Name	Description	Initial value
31:26	-	-	Reserved	7'b0
25:24	R/W	GDM1_SCH_MOD	2'b00: WRR 2'b01: Strict Priority, Q3>Q2>Q1>Q0 2'b10: Mixed, Q3>WRR(Q2,Q1,Q0) 2'b11: Reserved	2'b00
23:15	-	-	Reserved	1'b0
14:12	R/W	GDM1_WT_Q3	Q3's weight 3'd0: weight = 1 3'd1: weight = 2 3'd2: weight = 4 3'd3: weight = 8 3'd4: weight = 16	3'b011
11	-	-	Reserved	1'b0
10:8	R/W	GDM1_WT_Q2	Q2's weight 3'd0: weight = 1 3'd1: weight = 2 3'd2: weight = 4 3'd3: weight = 8 3'd4: weight = 16	3'b010
7	-	-	Reserved	1'b0
6:4	R/W	GDM1_WT_Q1	Q1's weight 3'd0: weight = 1 3'd1: weight = 2 3'd2: weight = 4 3'd3: weight = 8 3'd4: weight = 16	3'b001
3	-	-	Reserved	1'b0
2:0	R/W	GDM1_WT_Q0	Q0's weight 3'd0: weight = 1 3'd1: weight = 2 3'd2: weight = 4 3'd3: weight = 8 3'd4: weight = 16	3'b0

GDMA1_SHPR_CFG: GDMA1 Output Shaper Configuration (offset: 0x08)

Bits	Type	Name	Description	Initial value
31:25	-	-	Reserved	7'b0

24	R/W	GDM1_SHPR_EN	GDMA1 output shaper enable. 0: Disable 1: Enable	1'b0
23:16	R/W	GDM1_BK_SIZE	GDMA1 output shaper maximum bucket size. Unit is 1kB.	8'b0
15:14	-	-	Reserved	2'b0
13:0	R/W	GDM1_TK_RATE	GDMA1 output shaper token rate. Unit is 8B/ms.	14'b0

GDMA_MAC_ADRL: GDMA 1 & 2 MAC Address LSB (offset: 0x0C)

Bits	Type	Name	Description	Initial value
31:0	R/W	GDM1_MY_MAC_L	GDMA 1 & 2 MAC address bit 31-0	32'b0

GDMA_MAC_ADRH: GDMA 1 & 2 MAC Address MSB (offset: 0x10)

Bits	Type	Name	Description	Initial value
31:16	-	-	Reserved	16'b0
15:0	R/W	GDM1_MY_MAC_H	GDMA 1 & 2 MAC address bit 47-32	16'b0

3.17.3.3 Register Description - PSE (base: 0x1010.0040)

PSE_FQ_CFG: PSE_FQ_CFG Register (offset: 0x00)

Bits	Type	Name	Description	Initial value
31:24	R/W	FQ_MAX_PCNT	Maximum free Q page count. Please reset PSE after re-programming this register.	8'h80
23:16	R/W	FQ_FC_RLS	Free Q flow control release threshold.	8'h50
15:8	R/W	FQ_FC_ASRT	Free Q flow control assertion threshold.	8'h40
7:0	R/W	FQ_FC_DROP	Free Q empty threshold. If one input port is FC asserted and this threshold is reached, PSE will drop any new coming frame from this port.	8'h00

CDMA_FC_CFG: CDMA_FC_CFG Register (offset: 0x04)

Bits	Type	Name	Description	Initial value
31:29	-	-	Reserved	3'b0
28	R/W	P0_SHARING	Allows high priority Q to share low priority Q's reserved pages. 1: enable 0: disable	1'b1
27:24	R/W	P0_HQ_DEF	Bit map definition of high priority Q. '1' presents high priority Q, and '0' presents low priority Q. bit 27: Q3 priority definition bit 26: Q2 priority definition bit 25: Q1 priority definition bit 24: Q0 priority definition	4'b1100
23:16	R/W	P0_HQ_RESV	Reserved page count for high priority Q.	8'h10
15:8	R/W	P0_LQ_RESV	Reserved page count for low priority Q.	8'h10
7:0	R/W	P0_IQ_ASRT	Virtual input Q FC assertion threshold.	8'h10

GDMA1_FC_CFG: GDMA1_FC_CFG Register (offset: 0x08)

Bits	Type	Name	Description	Initial value
31:29	-	-	Reserved	3'b0
28	R/W	P1_SHARING	Allows high priority Q to share low priority Q's reserved pages. 1: enable 0: disable	1'b1
27:24	R/W	P1_HQ_DEF	Bit map definition of high priority Q. '1' presents high priority Q, and '0' presents low priority Q. bit 27: Q3 priority definition bit 26: Q2 priority definition bit 25: Q1 priority definition bit 24: Q0 priority definition	4'b1100
23:16	R/W	P1_HQ_RESV	Reserved page count for high priority Q.	8'h10
15:8	R/W	P1_LQ_RESV	Reserved page count for low priority Q.	8'h10
7:0	R/W	P1_IQ_ASRT	Virtual input Q FC assertion threshold.	8'h10

GDMA2_FC_CFG: GDMA2_FC_CFG Register (offset: 0x0C)

Bits	Type	Name	Description	Initial value
31:29	-	-	Reserved	3'b0
28	R/W	P2_SHARING	Allows high priority Q to share low priority Q's reserved pages. 1: enable 0: disable	1'b1
27:24	R/W	P2_HQ_DEF	Bit map definition of high priority Q. '1' presents high priority Q, and '0' presents low priority Q. bit 27: Q3 priority definition bit 26: Q2 priority definition bit 25: Q1 priority definition bit 24: Q0 priority definition	4'b1100
23:16	R/W	P2_HQ_RESV	Reserved page count for high priority Q.	8'h10
15:8	R/W	P2_LQ_RESV	Reserved page count for low priority Q.	8'h10
7:0	R/W	P2_IQ_ASRT	Virtual input Q FC assertion threshold.	8'h10

CDMA_OQ_STA: CDMA_OQ_STA Register (offset: 0x10)

Bits	Type	Name	Description	Initial value
31:24	RO	P0_OQ3_PCNT	CDMA output Q3 page count.	8'b0
23:16	RO	P0_OQ2_PCNT	CDMA output Q2 page count.	8'b0
15:8	RO	P0_OQ1_PCNT	CDMA output Q1 page count.	8'b0
7:0	RO	P0_OQ0_PCNT	CDMA output Q0 page count.	8'b0

GDMA1_OQ_STA: GDMA1_OQ_STA Register (offset: 0x14)

Bits	Type	Name	Description	Initial value
31:24	RO	P1_OQ3_PCNT	GDMA1 output Q3 page count.	8'b0
23:16	RO	P1_OQ2_PCNT	GDMA1 output Q2 page count.	8'b0
15:8	RO	P1_OQ1_PCNT	GDMA1 output Q1 page count.	8'b0
7:0	RO	P1_OQ0_PCNT	GDMA1 output Q0 page count.	8'b0

GDMA2_OQ_STA: GDMA2_OQ_STA Register (offset: 0x18)

Bits	Type	Name	Description	Initial value
31:24	RO	P2_OQ3_PCNT	GDMA2 output Q3 page count.	8'b0
23:16	RO	P2_OQ2_PCNT	GDMA2 output Q2 page count.	8'b0
15:8	RO	P2_OQ1_PCNT	GDMA2 output Q1 page count.	8'b0
7:0	RO	P2_OQ0_PCNT	GDMA2 output Q0 page count.	8'b0

PSE_IQ_STA: PSE_IQ_STA Register (offset: 0x1C)

Bits	Type	Name	Description	Initial value
31:24	RO	P6_OQ0_PCNT	PPE output Q0 page count.	8'b0
23:16	RO	P2_IQ_PCNT	GDMA2 virtual input Q page count.	8'b0
15:8	RO	P1_IQ_PCNT	GDMA1 virtual input Q page count.	8'b0
7:0	RO	P0_IQ_PCNT	CDMA virtual input Q page count.	8'b0

3.17.3.4 Register Description – GDMA2 (base: 0x1010.0060)
GDMA2_FWD_CFG: Reserved (offset: 0x00)
GDMA2_SCH_CFG: GDMA2 Scheduling Configuration (offset: 0x04)

Bits	Type	Name	Description	Initial value
31:26	-	-	Reserved	7'b0
25:24	R/W	GDM2_SCH_MOD	2'b00: WRR 2'b01: Strict Priority, Q3>Q2>Q1>Q0 2'b10: Mixed, Q3>WRR(Q2,Q1,Q0) 2'b11: Reserved	2'b00
23:15	-	-	Reserved	1'b0

14:12	R/W	GDM2_WT_Q3	Q3's weight 3'd0: weight = 1 3'd1: weight = 2 3'd2: weight = 4 3'd3: weight = 8 3'd4: weight = 16	3'b011
11	-	-	Reserved	1'b0
10:8	R/W	GDM2_WT_Q2	Q2's weight 3'd0: weight = 1 3'd1: weight = 2 3'd2: weight = 4 3'd3: weight = 8 3'd4: weight = 16	3'b010
7	-	-	Reserved	1'b0
6:4	R/W	GDM2_WT_Q1	Q1's weight 3'd0: weight = 1 3'd1: weight = 2 3'd2: weight = 4 3'd3: weight = 8 3'd4: weight = 16	3'b001
3	-	-	Reserved	1'b0
2:0	R/W	GDM2_WT_Q0	Q0's weight 3'd0: weight = 1 3'd1: weight = 2 3'd2: weight = 4 3'd3: weight = 8 3'd4: weight = 16	3'b0

GDMA2_SHPR_CFG: GDMA2 Output Shaper Configuration (offset: 0x08)

Bits	Type	Name	Description	Initial value
31:25	-	-	Reserved	7'b0
24	R/W	GDM2_SHPR_EN	GDMA2 output shaper enable. 0: Disable 1: Enable	1'b0
23:16	R/W	GDM2_BK_SIZE	GDMA2 output shaper maximum bucket size. Unit is 1kB.	8'b0
15:14	-	-	Reserved	2'b0
13:0	R/W	GDM2_TK_RATE	GDMA2 output shaper token rate. Unit is 8B/ms.	14'b0

3.17.3.5 Register Description - CPU Port (base: 0x1010.0080)

CDMA_CSG_CFG: CDMA_CSG_CFG Register (offset: 0x00)

Bits	Type	Name	Description	Initial value
31:16	R/W	INS_VLAN_	Inserted VLAN type	16'h8100
15:3	-	-	Reserved	13'b0
2	R/W	ICS_GEN_EN	IPv4 header checksum generation enable	1'b0
1	R/W	UCS_GEN_EN	UCP checksum generation enable	1'b0
0	R/W	TCS_GEN_EN	TDP checksum generation enable	1'b0

CDMA_SCH_CFG: CDMA_SCH_CFG Register (offset: 0x04)

Bits	Type	Name	Description	Initial value
31:26	-	-	Reserved	6'b0
25:24	R/W	CDM_SCH_MOD	2'b00: WRR 2'b01: Strict Priority, Q3>Q2>Q1>Q0 2'b10: Mixed, Q3>WRR(Q2,Q1,Q0) 2'b11: Reserved	2'b00
23:15	-	-	Reserved	9'b0

14:12	R/W	CDM_WT_Q3	Q3's weight 3'd0: weight = 1 3'd1: weight = 2 3'd2: weight = 4 3'd3: weight = 8 3'd4: weight = 16	3'b011
11	-	-	Reserved	1'b0
10:8	R/W	CDM_WT_Q2	Q2's weight 3'd0: weight = 1 3'd1: weight = 2 3'd2: weight = 4 3'd3: weight = 8 3'd4: weight = 16	3'b010
7	-	-	Reserved	1'b0
6:4	R/W	CDM_WT_Q1	Q1's weight 3'd0: weight = 1 3'd1: weight = 2 3'd2: weight = 4 3'd3: weight = 8 3'd4: weight = 16	3'b001
3	-	-	Reserved	1'b0
2:0	R/W	CDM_WT_Q0	Q0's weight 3'd0: weight = 1 3'd1: weight = 2 3'd2: weight = 4 3'd3: weight = 8 3'd4: weight = 16	3'b000

PPPOE_SID_0001: PPPOE_SID_0001 Register (offset: 0x08)

Bits	Type	Name	Description	Initial value
31:16	R/W	PPPOE_SID1	PPPoE Session ID for SID INDEX#1	16'b0
15:0	R/W	PPPOE_SID0	PPPoE Session ID for SID INDEX#0	16'b0

PPPOE_SID_0203: PPPOE_SID_0203 Register (offset: 0x0C)

Bits	Type	Name	Description	Initial value
31:16	R/W	PPPOE_SID3	PPPoE Session ID for SID INDEX#3	16'b0
15:0	R/W	PPPOE_SID2	PPPoE Session ID for SID INDEX#2	16'b0

PPPOE_SID_0405: PPPOE_SID_0405 Register (offset: 0x10)

Bits	Type	Name	Description	Initial value
31:16	R/W	PPPOE_SID5	PPPoE Session ID for SID INDEX#5	16'b0
15:0	R/W	PPPOE_SID4	PPPoE Session ID for SID INDEX#4	16'b0

PPPOE_SID_0607: PPPOE_SID_0607 Register (offset: 0x14)

Bits	Type	Name	Description	Initial value
31:16	R/W	PPPOE_SID7	PPPoE Session ID for SID INDEX#7	16'b0
15:0	R/W	PPPOE_SID6	PPPoE Session ID for SID INDEX#6	16'b0

PPPOE_SID_0809: PPPOE_SID_0809 Register (offset: 0x18)

Bits	Type	Name	Description	Initial value
31:16	R/W	PPPOE_SID9	PPPoE Session ID for SID INDEX#9	16'b0
15:0	R/W	PPPOE_SID8	PPPoE Session ID for SID INDEX#8	16'b0

PPPOE_SID_1011: PPPOE_SID_1011 Register (offset: 0x1C)

Bits	Type	Name	Description	Initial value
31:16	R/W	PPPOE_SID11	PPPoE Session ID for SID INDEX#11	16'b0
15:0	R/W	PPPOE_SID10	PPPoE Session ID for SID INDEX#10	16'b0

PPPOE_SID_1213: PPPOE_SID_1213 Register (offset: 0x20)

Bits	Type	Name	Description	Initial value
31:16	R/W	PPPOE_SID13	PPPoE Session ID for SID INDEX#13	16'b0
15:0	R/W	PPPOE_SID12	PPPoE Session ID for SID INDEX#12	16'b0

PPPOE_SID_1415: PPPOE_SID_1415 Register (offset: 0x24)

Bits	Type	Name	Description	Initial value
31:16	R/W	PPPOE_SID15	PPPoE Session ID for SID INDEX#15	16'b0
15:0	R/W	PPPOE_SID14	PPPoE Session ID for SID INDEX#14	16'b0

VLAN_ID_0001: VLAN_ID_0001 Register (offset: 0x28)

Bits	Type	Name	Description	Initial value
31:28	-	-	Reserved	4'b0
27:16	R/W	VLAN_ID0	VLAN ID of VLAN0	12'b0
15:12	-	-	Reserved	4'b0
11:0	R/W	VLAN_ID1	VLAN ID of VLAN1	12'b0

VLAN_ID_0203: VLAN_ID_0203 Register (offset: 0x2C)

Bits	Type	Name	Description	Initial value
31:28	-	-	Reserved	4'b0
27:16	R/W	VLAN_ID2	VLAN ID of VLAN2	12'b0
15:12	-	-	Reserved	4'b0
11:0	R/W	VLAN_ID3	VLAN ID of VLAN3	12'b0

VLAN_ID_0405: VLAN_ID_0405 Register (offset: 0x30)

Bits	Type	Name	Description	Initial value
31:28	-	-	Reserved	4'b0
27:16	R/W	VLAN_ID4	VLAN ID of VLAN4	12'b0
15:12	-	-	Reserved	4'b0
11:0	R/W	VLAN_ID5	VLAN ID of VLAN5	12'b0

VLAN_ID_0607: VLAN_ID_0607 Register (offset: 0x34)

Bits	Type	Name	Description	Initial value
31:28	-	-	Reserved	4'b0
27:16	R/W	VLAN_ID6	VLAN ID of VLAN6	12'b0
15:12	-	-	Reserved	4'b0
11:0	R/W	VLAN_ID7	VLAN ID of VLAN7	12'b0

VLAN_ID_0809: VLAN_ID_0809 Register (offset: 0x38)

Bits	Type	Name	Description	Initial value
31:28	-	-	Reserved	4'b0
27:16	R/W	VLAN_ID8	VLAN ID of VLAN8	12'b0
15:12	-	-	Reserved	4'b0
11:0	R/W	VLAN_ID9	VLAN ID of VLAN9	12'b0

VLAN_ID_1011: VLAN_ID_1011 Register (offset: 0x3C)

Bits	Type	Name	Description	Initial value
31:28	-	-	Reserved	4'b0
27:16	R/W	VLAN_ID10	VLAN ID of VLAN10	12'b0
15:12	-	-	Reserved	4'b0
11:0	R/W	VLAN_ID11	VLAN ID of VLAN11	12'b0

VLAN_ID_1213: VLAN_ID_1213 Register (offset: 0x40)

Bits	Type	Name	Description	Initial value
31:28	-	-	Reserved	4'b0
27:16	R/W	VLAN_ID12	VLAN ID of VLAN12	12'b0

15:12	-	-	Reserved	4'b0
11:0	R/W	VLAN_ID13	VLAN ID of VLAN13	12'b0

VLAN_ID_14_15: VLAN_ID_14_15 Register (offset: 0x44)

Bits	Type	Name	Description	Initial value
31:28	-	-	Reserved	4'b0
276	R/W	VLAN_ID_14	VLAN ID of VLAN14	12'b0
15:12	-	-	Reserved	4'b0
110	R/W	VLAN_ID_15	VLAN ID of VLAN15	12'b0

3.17.3.6 Register Description - PDMA (base: 0x1010.0100)

PDMA_GLO_CFG: PDMA_GLO_CFG Register (offset: 0x00)

Bits	Type	Name	Description	Initial value
31:30	-	-	Reserved	2'b0
29:16	R/W	HDR_SEG_LEN	Specify the header segment size in byte to support RX header/payload scattering function, when set to a non-zero value. When set to zero, the header/payload scattering feature is disabled.	14'b0
15:8	-	-	Reserved	8'b0
7	-	-	Reserved	1'b0
6	R/W	TX_WB_DDONE	0: Disable TX_DMA writing back DDONE into TXD 1: Enable TX_DMA writing back DDONE into TXD	1'b1
5:4	R/W	PDMA_BT_SIZE	Define the burst size of PDMA 0: 4 DWORD (16bytes) 1: 8 DWORD (32 bytes) 2: 16 DWORD (64 bytes) 3: Reserved	2'd2
3	RO	RX_DMA_BUSY	1: RX_DMA is busy 0: RX_DMA is not busy	1'b0
2	R/W	RX_DMA_EN	1: Enable RX_DMA 0: Disable RX_DMA (when disabled, RX_DMA will finish the current receiving packet, then stop.)	1'b0
1	RO	TX_DMA_BUSY	1: TX_DMA is busy 0: TX_DMA is not busy	1'b0
0	R/W	TX_DMA_EN	1: Enable TX_DMA 0: Disable TX_DMA (when disabled, TX_DMA will finish the current sending packet, then stop.)	1'b0

PDMA_RST_IDX: PDMA_RST_IDX Register (offset: 0x04)

Bits	Type	Name	Description	Initial value
31:17	-	-	Reserved	15'b0
16	W1C	RST_DRX_IDX0	Write 1 to reset to RX_DRX_IDX0 to 0	1'b0
15:4	-	-	Reserved	12'b0
3	W1C	RST_DTX_IDX3	Write 1 to reset to TX_DTX_IDX3 to 0	1'b0
2	W1C	RST_DTX_IDX2	Write 1 to reset to TX_DTX_IDX2 to 0	1'b0
1	W1C	RST_DTX_IDX1	Write 1 to reset to TX_DTX_IDX1 to 0	1'b0
0	W1C	RST_DTX_IDX0	Write 1 to reset to TX_DTX_IDX0 to 0	1'b0

PDMA_SCH_CFG: PDMA_SCH_CFG Register (offset: 0x08)

Bits	Type	Name	Description	Initial value
31:26	-	-	Reserved	7'b0
25:24	R/W	PDM_SCH_MOD	2'b00: WRR 2'b01: Strict Priority, Q3>Q2>Q1>Q0 2'b10: Mixed, Q3>WRR(Q2,Q1,Q0) 2'b11: Reserved	2'b00
23:15	-	-	Reserved	1'b0

14:12	R/W	PDM_WT_Q3	Q1's weight 3'd0: weight = 1 3'd1: weight = 2 3'd2: weight = 4 3'd3: weight = 8 3'd4: weight = 16	3'b011
11	-	-	Reserved	1'b0
10:8	R/W	PDM_WT_Q2	Q0's weight 3'd0: weight = 1 3'd1: weight = 2 3'd2: weight = 4 3'd3: weight = 8 3'd4: weight = 16	3'b010
7	-	-	Reserved	1'b0
6:4	R/W	PDM_WT_Q1	Q1's weight 3'd0: weight = 1 3'd1: weight = 2 3'd2: weight = 4 3'd3: weight = 8 3'd4: weight = 16	3'b001
3	-	-	Reserved	1'b0
2:0	R/W	PDM_WT_Q0	Q0's weight 3'd0: weight = 1 3'd1: weight = 2 3'd2: weight = 4 3'd3: weight = 8 3'd4: weight = 16	3'b000

DLY_INT_CFG: DLY_INT_CFG Register (offset: 0x0C)

Bits	Type	Name	Description	Initial value
31	RW	TXDLY_INT_EN	1: Enable TX delayed interrupt mechanism. 0: Disable TX delayed interrupt mechanism.	1'b0
30:24	RW	TXMAX_PINT	Specified Max # of pended interrupts. When the # of pended interrupts is equal to or greater than the value specified here or interrupt pending time reach the limit (See below), a Final TX_DLY_INT is generated. Set to 0 will disable this feature	7'b0
23:16	RW	TXMAX_PTIME	Specified Max pending time for the internal TX_DONE_INT0 and TX_DONE_INT1. When the pending time equal or greater TXMAX_PTIME x 20us or the # of pended TX_DONE_INT0 and TX_DONE_INT1 equal or greater than TXMAX_PINT (see above), an Final TX_DLY_INT is generated Set to 0 will disable this feature	8'b0
15	RW	RXDLY_INT_EN	1: Enable RX delayed interrupt mechanism. 0: Disable RX delayed interrupt mechanism.	1'b0
14:8	RW	RXMAX_PINT	Specified Max # of pended interrupts. When the # of pended interrupts equal or greater than the value specified here or interrupt pending time reach the limit (See below), a Final RX_DLY_INT is generated. Set to 0 will disable this feature	7'b0
7:0	RW	RXMAX_PTIME	Specified Max pending time for the internal RX_DONE_INT. When the pending time equal or greater RXMAX_PTIME x 20us or, the # of pended RX_DONE_INT equal or greater than RXMAX_PCNT (see above), an Final RX_DLY_INT is generated Set to 0 will disable this feature.	8'b0

TX_BASE_PTR0: TX_BASE_PTR0 Register (offset: 0x10)

Bits	Type	Name	Description	Initial value
31:0	R/W	TX_BASE_PTR0	Point to the base address of TX_Ring0 (4-DWORD aligned address)	32'b0

TX_MAX_CNT0: TX_MAX_CNT0 Register (offset: 0x14)

Bits	Type	Name	Description	Initial value
31:12	-	-	Reserved	20'b0
11:0	R/W	TX_MAX_CNT0	The maximum number of TXD count in TXD_Ring0.	12'b0

TX_CTX_IDX0: TX_CTX_IDX0 Register (offset: 0x18)

Bits	Type	Name	Description	Initial value
31:12	-	-	Reserved	20'b0
11:0	R/W	TX_CTX_IDX0	Point to the next TXD in TXD_Ring0 CPU wants to use	12'b0

TX_DTX_IDX0: TX_DTX_IDX0 Register (offset: 0x1C)

Bits	Type	Name	Description	Initial value
31:12	-	-	Reserved	20'b0
11:0	RO	TX_DTX_IDX0	Point to the next TXD in TXD_Ring0 DMA wants to use	12'b0

TX_BASE_PTR1: TX_BASE_PTR1 Register (offset: 0x20)

Bits	Type	Name	Description	Initial value
31:0	R/W	TX_BASE_PTR1	Point to the base address of TX_Ring1 (4-DWORD aligned address)	32'b0

TX_MAX_CNT1: TX_MAX_CNT1 Register (offset: 0x24)

Bits	Type	Name	Description	Initial value
31:12	-	-	Reserved	20'b0
11:0	R/W	TX_MAX_CNT1	The maximum number of TXD count in TXD_Ring1.	12'b0

TX_CTX_IDX1: TX_CTX_IDX1 Register (offset: 0x28)

Bits	Type	Name	Description	Initial value
31:12	-	-	Reserved	20'b0
11:0	R/W	TX_CTX_IDX1	Point to the next TXD in TXD_Ring1 CPU wants to use	12'b0

TX_DTX_IDX1: TX_DTX_IDX1 Register (offset: 0x2C)

Bits	Type	Name	Description	Initial value
31:12	-	-	Reserved	20'b0
11:0	RO	TX_DTX_IDX1	Point to the next TXD in TXD_Ring1 DMA wants to use	0

RX_BASE_PTR0: RX_BASE_PTR0 Register (offset: 0x30)

Bits	Type	Name	Description	Initial value
31:0	R/W	RX_BASE_PTR0	Point to the base address of RXD Ring #0. It should be a 4-DWORD aligned address	0

RX_MAX_CNT0: RX_MAX_CNT0 Register (offset: 0x34)

Bits	Type	Name	Description	Initial value
31:12	R-	-	Reserved	0
11:0	R/W	RX_MAX_CNT0	The maximum number of RXD count in RXD Ring #0.	0

RX_CALC_IDX0: RX_CALC_IDX0 Register (offset: 0x38)

Bits	Type	Name	Description	Initial value
31:12	-	-	Reserved	0
11:0	R/W	RX_CALC_IDX0	Point to the next RXD CPU wants to allocate to RXD Ring #0.	0

RX_DRX_IDX0: RX_DRX_IDX0 Register (offset: 0x3C)

Bits	Type	Name	Description	Initial value
31:12	RO	-	Reserved	0
11:0	RO	RX_DRX_IDX0	Point to the next RXD DMA wants to use in RXD Ring#0. It should be a 4-DWORD aligned address.	0

TX_BASE_PTR2: TX_BASE_PTR2 Register (offset: 0x40)

Bits	Type	Name	Description	Initial value
31:0	R/W	TX_BASE_PTR2	Point to the base address of TX_Ring2 (4-DWORD aligned address)	32'b0

TX_MAX_CNT2: TX_MAX_CNT2 Register (offset: 0x44)

Bits	Type	Name	Description	Initial value
31:12	-	-	Reserved	20'b0
11:0	R/W	TX_MAX_CNT2	The maximum number of TXD count in TXD_Ring2.	12'b0

TX_CTX_IDX2: TX_CTX_IDX2 Register (offset: 0x48)

Bits	Type	Name	Description	Initial value
31:12	-	-	Reserved	20'b0
11:0	R/W	TX_CTX_IDX2	Point to the next TXD in TXD_Ring2 CPU wants to use	12'b0

TX_DTX_IDX2: TX_DTX_IDX2 Register (offset: 0x4C)

Bits	Type	Name	Description	Initial value
31:12	-	-	Reserved	20'b0
11:0	RO	TX_DTX_IDX2	Point to the next TXD in TXD_Ring2 DMA wants to use	0

TX_BASE_PTR3: TX_BASE_PTR3 Register (offset: 0x50)

Bits	Type	Name	Description	Initial value
31:0	R/W	TX_BASE_PTR3	Point to the base address of TX_Ring3 (4-DWORD aligned address)	32'b0

TX_MAX_CNT3: TX_MAX_CNT3 Register (offset: 0x54)

Bits	Type	Name	Description	Initial value
31:12	-	-	Reserved	20'b0
11:0	R/W	TX_MAX_CNT3	The maximum number of TXD count in TXD_Ring3.	12'b0

TX_CTX_IDX3: TX_CTX_IDX3 Register (offset: 0x58)

Bits	Type	Name	Description	Initial value
31:12	-	-	Reserved	20'b0
11:0	R/W	TX_CTX_IDX3	Point to the next TXD in TXD_Ring3 CPU wants to use	12'b0

TX_DTX_IDX3: TX_DTX_IDX3 Register (offset: 0x5C)

Bits	Type	Name	Description	Initial value
31:12	-	-	Reserved	20'b0
11:0	RO	TX_DTX_IDX3	Point to the next TXD in TXD_Ring3 DMA wants to use	0

PDMA_FC_CFG: PDMA_FC_CFG Register (offset: 0xF0)

Bits	Type	Name	Description	Initial value
31:30	-	-	Reserved	2'b0
29:24	R/W	PDM_FC_DEF_Q3	Q3 flow control pause condition Bit[5]: pause Q3 when PSE P2 high Q full Bit[4]: pause Q3 when PSE P2 low Q full Bit[3]: pause Q3 when PSE P1 high Q full Bit[2]: pause Q3 when PSE P1 low Q full Bit[1]: pause Q3 when PSE P0 high Q full Bit[0]: pause Q3 when PSE P0 low Q full	6'b111111
23:22	-	-	Reserved	2'b0
21:16	R/W	PDM_FC_DEF_Q2	Q2 flow control pause condition Bit[5]: pause Q2 when PSE P2 high Q full Bit[4]: pause Q2 when PSE P2 low Q full Bit[3]: pause Q2 when PSE P1 high Q full Bit[2]: pause Q2 when PSE P1 low Q full Bit[1]: pause Q2 when PSE P0 high Q full Bit[0]: pause Q2 when PSE P0 low Q full	6'b111111
15:14	-	-	Reserved	2'b0

13:8	R/W	PDM_FC_DEF_Q1	Q1 flow control pause condition Bit[5]: pause Q1 when PSE P2 high Q full Bit[4]: pause Q1 when PSE P2 low Q full Bit[3]: pause Q1 when PSE P1 high Q full Bit[2]: pause Q1 when PSE P1 low Q full Bit[1]: pause Q1 when PSE P0 high Q full Bit[0]: pause Q1 when PSE P0 low Q full	6'b111111
7:6	-	-	Reserved	2'b0
5:0	R/W	PDM_FC_DEF_Q0	Q0 flow control pause condition Bit[5]: pause Q0 when PSE P2 high Q full Bit[4]: pause Q0 when PSE P2 low Q full Bit[3]: pause Q0 when PSE P1 high Q full Bit[2]: pause Q0 when PSE P1 low Q full Bit[1]: pause Q0 when PSE P0 high Q full Bit[0]: pause Q0 when PSE P0 low Q full	6'b111111

3.17.3.7 Register Description – Frame Engine Counters (base: 0x1010.0400)

Counter & Meter Table		
0x000	PPE_AC_BCNT0	PPE Accounting Group #0 Byte Counter
0x004	PPE_AC_PCNT0	PPE Accounting Group #0 Packet Counter

0x1F8	PPE_AC_BCNT63	PPE Accounting Group #63 Byte Counter
0x1FC	PPE_AC_PCNT63	PPE Accounting Group #63 Packet Counter
0x200	PPE_MTR_CNT0	-
	...	-
0x2FC	PPE_MTR_CNT63	-
0x300	GDMA_TX_GBCNT0	Transmit good byte count for GDMA port#1&2
0x304	GDMA_TX_GPCNT0	Transmit good pkt count for GDMA port#1&2 (not including flow control frames)
0x308	GDMA_TX_SKIPCNT0	Transmit skip count for GDMA port#1&2
0x30C	GDMA_TX_COLCNT0	Transmit collision count for GDMA port#1&2
0x310 – 0x31C	Reserved	-
0x320	GDMA_RX_GBCNT0	Received good byte count for GDMA port#1&2
0x324	GDMA_RX_GPCNT0	Received good pkt count for GDMA port#1&2 (not including flow control frames)
0x328	GDMA_RX_OERCNT0	Received overflow error pkt count for GDMA port#1&2
0x32C	GDMA_RX_FERCNT0	Received FCS error pkt count for GDMA port#1&2
0x330	GDMA_RX_SERCNT0	Received too short error pkt count for GDMA port#1&2
0x334	GDMA_RX_LERCNT0	Received too long error pkt count for GDMA port#1&2
0x338	GDMA_RX_CERCNT0	Received ip/tcp/udp checksum error pkt count for GDMA port#1&2
0x33C	Reserved	-

3.18 Ethernet Switch

3.18.1 Features

- Support IEEE 802.3 full duplex flow control
- 5 10/100Mbps PHY
- Support Spanning Tree port states
- Support 1K-MAC address table with direct or XOR hash
- QoS
 - Four priorities queues per port
 - Packet classification based on incoming port, IEEE 802.1p or IP ToS/DSCP
 - Strict-Priority Queue (PQ) and Weighted Round Robin (WRR)
- VLAN
 - Port Base VLAN
 - Double VLAN tagging
 - 802.1q tag VLAN
 - 16 VIDs
- MAC address table read and write-able
- MAC security – Locking a MAC address to an incoming port
- MAC clone support – hash with VID
- IGMP support
- Broadcast storm prevention

3.18.2 Block Diagram

Fig. 3-18-1 Ethernet Switch Block Diagram

3.18.3 Register Description (base: 0x1011.0000)

Note: In RT3050, the registers related P5 (port 5) are not applicable. Please keep them as default settings

ISR: Interrupt Status Register (offset: 0x00)

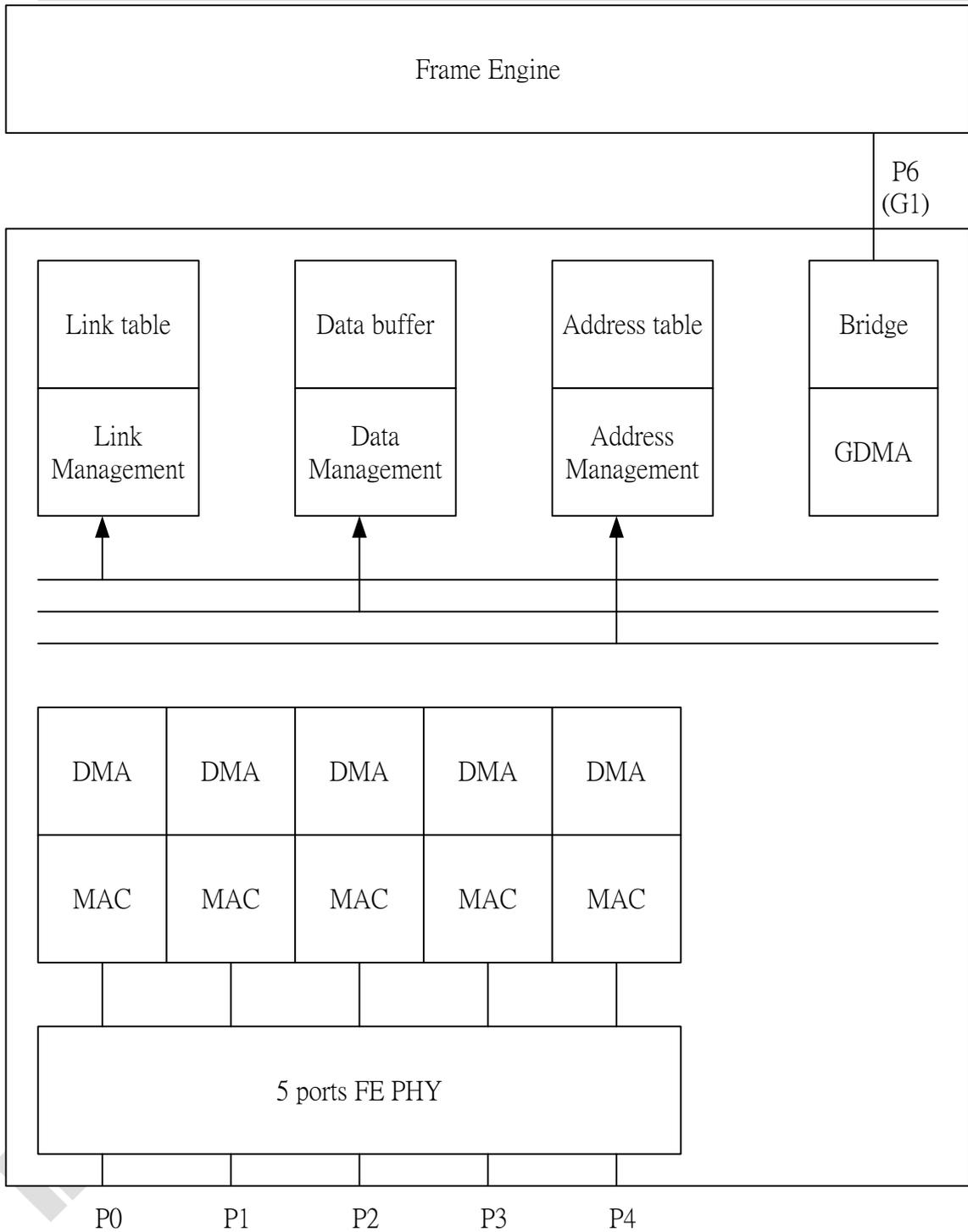
Bits	Type	Name	Description	Initial value
31:30	RO	-	Reserved	3'b0
29	RO	-	Reserved	1'b0
28	R/W	WATCHDOG0_TMR_EXPIRED	Abnormal Alert This bit indicating that global queue block counts is less than buf_starvation_th for 3 seconds. Write one clear.	1'b0
27	R/W	HAS_INTRUDER	Intruder Alert This bit indicating that an unsecured packet is coming into a secured port. Write one clear.	1'b0
26	R/W	PORT_ST_CHG	Port status change Any port from link status change. Write one clear.	1'b0
25	R/W	BC_STORM	BC storm The device is undergoing broadcast storm. Write one clear.	1'b0
24	R/W	MUST_DROP_LAN	Queue exhausted The global queue is used up and all packets are dropped. Write one clear.	1'b0
23	R/W	GLOBAL_QUE_FULL	Global Queue Full. Write one clear.	1'b0
22:21	RO	-	Reserved	2'b0
20	R/W	LAN_QUE_FULL[6]	Port6 out queue full. Write one clear.	1'b0
19	-	-	Reserved	1'b0
18	R/W	LAN_QUE_FULL[4]	Port4 out queue full. Write one clear.	1'b0
17	R/W	LAN_QUE_FULL[3]	Port3 out queue full. Write one clear.	1'b0
16	R/W	LAN_QUE_FULL[2]	Port2 out queue full. Write one clear.	1'b0
15	R/W	LAN_QUE_FULL[1]	Port1 out queue full. Write one clear.	1'b0
14	R/W	LAN_QUE_FULL[0]	Port0 out queue full. Write one clear.	1'b0
13:0	RO	-	Reserved	14'b0

IMR: Interrupt Mask Register (offset: 0x04)

Bits	Type	Name	Description	Initial value
31	RO	-	Reserved	1'b0
30	R/W	SW_INT_MASK_30	Reserved	1'b1
29	R/W	SW_INT_MASK_29	Reserved	1'b1
28	R/W	SW_INT_MASK_28	Abnormal Alert This bit indicating that global queue block counts is less than buf_starvation_th for 3 seconds. Write one clear.	1'b1
27	R/W	SW_INT_MASK_27	Intruder Alert This bit indicating that an unsecured packet is coming into a secured port.	1'b1
26	R/W	SW_INT_MASK_26	Port status change Any port from link status change	1'b1
25	R/W	SW_INT_MASK_25	BC storm The device is undergoing broadcast storm	1'b1
24	R/W	SW_INT_MASK_24	Queue exhausted The global queue is used up and all packets are dropped	1'b1
23	R/W	SW_INT_MASK_23	Shared queue full	1'b1
22	R/W	SW_INT_MASK_22	Reserved	1'b1
21	R/W	SW_INT_MASK_21	Reserved	1'b1
20	R/W	SW_INT_MASK_20	port6 queue full	1'b1

19	-	-	Reserved	1'b1
18	R/W	SW_INT_MASK_18	port4 queue full	1'b1
17	R/W	SW_INT_MASK_17	port3 queue full	1'b1
16	R/W	SW_INT_MASK_16	port2 queue full	1'b1
15	R/W	SW_INT_MASK_15	port1 queue full	1'b1
14	R/W	SW_INT_MASK_14	port0 queue full	1'b1
13	R/W	SW_INT_MASK_13	Reserved	1'b1
12	R/W	SW_INT_MASK_12	Reserved	1'b1
11	R/W	SW_INT_MASK_11	Reserved	1'b1
10	R/W	SW_INT_MASK_10	Reserved	1'b1
9	R/W	SW_INT_MASK_9	Reserved	1'b1
8	R/W	SW_INT_MASK_8	Reserved	1'b1
7	R/W	SW_INT_MASK_7	Reserved	1'b1
6	R/W	SW_INT_MASK_6	Reserved	1'b1
5	R/W	SW_INT_MASK_5	Reserved	1'b1
4	R/W	SW_INT_MASK_4	Reserved	1'b1
3	R/W	SW_INT_MASK_3	Reserved	1'b1
2	R/W	SW_INT_MASK_2	Reserved	1'b1
1	R/W	SW_INT_MASK_1	Reserved.	1'b1
0	R/W	SW_INT_MASK_0	Reserved	1'b1

FCT0: Flow Control Threshold 0 (offset: 0x08)

Bits	Type	Name	Description	Initial value
31:24	R/W	FC_RLS_TH	Flow Control Release Threshold Flow control is off when the global queue block counts is greater than the threshold	8'd255
23:16	R/W	FC_SET_TH	Flow Control Set Threshold Flow control will be checked when global queue block counts is less than the threshold	8'd200
15:8	R/W	DROP_RLS_TH	Drop Release Threshold Packets will stop dropping when the global queue block counts is greater than the threshold	8'd110
7:0	R/W	DROP_SET_TH	Drop Set Threshold Packets will start dropping when the global queue block counts is less than the threshold.	8'd90

FCT1: Flow Control Threshold 1 (B + 0C)

Bits	Type	Name	Description	Initial value
31:8	RO	-	Reserved	24'd0
7:0	R/W	PORT_TH	Per_Port_Th Per port out queue threshold.	8'd20

PFC0: Priority flow control – 0 (offset: 0x10)

Bits	Type	Name	Description	Initial value
31:28	-	-	Reserved	4'd0
27:24	R/W	MTCC_LMT	MTCC LIMIT Back-off count limit.	4'd15
23:16	R/W	TURN_OFF_FC	Turn off FC When Receiving High Packet Auto-turn-off FC when the programmed ports receive priority packet → <u>0: disable</u>	8'd0
15:12	R/W	VO_NUM	The proportional number of WRR → after transmit exactly the number of packets then proceed to next queue, If equal to 0, force to unlimited mode	4'd0

11:8	R/W	CL_NUM	The proportional number of WRR → after transmit exactly the number of packet then proceed to next queue.	4'd0
7:4	R/W	BE_NUM	The proportional number of WRR → after transmit exactly the number of packet then proceed to next queue.	4'd0
3:0	R/W	BK_NUM	The proportional number of WRR → after transmit exactly the number of packet then proceed to next queue.	4'd0

PFC1: Priority Flow control –1 (offset: 0x14)

Bits	Type	Name	Description	Initial value
31	R/W	P6_USE_Q1_EN	Port6 only use q1 enable	1'd0
30	R/W	EN_TOS[6]	Port6 TOS_en. 0: disable	7'd0
29	-	-	Reserved	
28:24	R/W	EN_TOS[4:0]	Port4 ~ port0 TOS_en. 0: disable	7'd0
23:16	R/O	EN_VLAN	Enable per port VLAN ID and priority check.0: disable.	8'd0
15:14	R/W	-	Reserved	2'b01
13:12	R/W	PORT_PRI6	Port priority By setting this register to force per port's default priority.	2'b01
11:10	-	-	Reserved	2'b01
9:8	R/W	PORT_PRI4	Port priority By setting this register to force per port's default priority.	2'b01
7:6	R/W	PORT_PRI3	Port priority By setting this register to force per port's default priority.	2'b01
5:4	R/W	PORT_PRI2	Port priority By setting this register to force per port's default priority.	2'b01
3:2	R/W	PORT_PRI1	Port priority By setting this register to force per port's default priority.	2'b01
1:0	R/W	PORT_PRI0	Port priority By setting this register to force per port's default priority.	2'b01

PFC2: Priority flow control –2 (offset: 0x18)

Bits	Type	Name	Description	Initial value
31:24	R/W	PRI_TH_VO	Voice Threshold – Highest Priority The minimum per port out queue can store high packet block count	8'd3
23:16	R/W	PRI_TH_CL	Control Load Threshold The minimum per port out queue can store low packet block count	8'd3
15:8	R/W	PRI_TH_BE	Best Effort threshold The minimum per port out queue can store low packet block count	8'd3
7:0	R/W	PRI_TH_BK	Background Threshold – Lowest Priority The minimum per port out queue can store low packet block count	8'd3

GQS0: Global Queue Status – 0 (offset: 0x1C)

Bits	Type	Name	Description	Initial value
31:9	RO	-	Reserved	23'd0
8:0	RO	EMPTY_CNT	Global Queue Block Counts The number of block count left in queue	9'h16b

GQS1: Global Queue Status – 1 (offset: 0x20)

Bits	Type	Name	Description	Initial value
------	------	------	-------------	---------------

31:24	RO	OUTQUE_FULL_VO	Congested Voice Queue The corresponding congested low queue	8'd0
23:16	RO	OUTQUE_FULL_CL	Congested Control Load Queue The corresponding congested low queue	8'd0
15:8	RO	OUTQUE_FULL_BE	Congested Best Effort Queue The corresponding congested low queue	8'd0
7:0	RO	OUTQUE_FULL_BK	Congested Background Queue The corresponding congested low queue	8'd0

ATS: Address Table Search (offset: 0x24)

Bits	Type	Name	Description	Initial value
31:3	RO	-	Reserved	29'b0
2	RO	AT_LKUP_IDLE	Address Lookup Idle	1'b0
1	R/W	SEARCH_NXT_ADDR	Search For The Next Address (Self_Clear)	1'b0
0	R/W	BEGIN_SEARCH_ADDR	Start Searching The Address Table (Self_Clear)	1'b0

ATSO: Address Table Status 0 (offset: 0x28)

Bits	Type	Name	Description	Initial value
31:22	RO	HASH_ADD_LU	Address table lookup address	10'd0
21:19	RO	-	Reserved	3'd0
18:12	RO	R_PORT MAP	Port map The MAC existing in the bit =1.	7'd0
11	RO	-	Reserved	-
10:7	RO	R_VID	Member set index	4'd0
6:4	RO	R_AGE_FIELD	Aging field	3'd0
3	RO	-	Reserved	-
2	RO	R_MC_INGRESS	MC Ingress	1'b0
1	RO	AT_TABLE_END	Search to the end of address table	1'b0
0	RO	SEARCH_RDY	Data is ready (read clear)	1'b0

ATS1: Address Table Status 1 (offset: 0x2C)

Bits	Type	Name	Description	Initial value
31:16		-	Reserved	16'b0
15:0	RO	MAC_AD_SER0	Read MAC address [15:0]	16'bx

ATS2: Address Table Status 2 (offset: 0x30)

Bits	Type	Name	Description	Initial value
31:0	RO	MAC_AD_SER1	Read MAC address [47:16]	32'b0

WMAD0: WT_MAC_AD0 (offset: 0x34)

Bits	Type	Name	Description	Initial value
31:22	RO	HASH_ADD_CFG	Address table configuration address	10'd0
21:19	RO	-	Reserved	3'd0
19	RO	AT_CFG_IDLE	Address table configuration SM idle	1'b1
18:12	R/W	W_PORT_MAP	Write Port Map Number	7'b0
11	R/W	-	Reserved	
10:7	R/W	W_INDEX	Write Member Set Index	4'b0
6:4	R/W	W_AGE_FIELD	Write aging field, 111: static address, 000: not used. 001~110:used	3'b0
3	R/W	-	Reserved	
2	R/W	W_MC_INGRESS	Write Mc_Ingress Bit	1'b0
1	RO	W_MAC_DONE	MAC Write Done 1: MAC address write OK, (read_clear)	1'b0

0	R/W	W_MAC_CMD	MAC Address Write Command 1: the MAC write data is ready and write to MAC table now, self_clear	1'b0
---	-----	-----------	--	------

WMAD1: WT_MAC_AD1 (offset: 0x38)

Bits	Type	Name	Description	Initial value
31:16	RO	-	Reserved	16'b0
15:0	R/W	W_MAC_15_0	Write MAC address [15:0]	16'h0

WMAD2: WT_MAC_AD2 (offset: 0x3C)

Bits	Type	Name	Description	Initial value
31:0	R/W	W_MAC_47_16	Write MAC address [47:16]	32'b0

PVIDC0: PVID Configuration 0 (offset: 0x40)

Bits	Type	Name	Description	Initial value
31:24	RO	-	Reserved	8'd0
23:12	R/W	P1_PVID	Port1 PVID setting	12'd1
11:0	R/W	P0_PVID	Port0 PVID setting	12'd1

PVIDC1: PVID Configuration 1 (offset: 0x44)

Bits	Type	Name	Description	Initial value
31:24	RO	-	Reserved	8'd0
23:12	R/W	P3_PVID	Port3 PVID setting	12'd1
11:0	R/W	P2_PVID	Port2 PVID setting	12'd1

PVIDC2: PVID Configuration 2 (offset: 0x48)

Bits	Type	Name	Description	Initial value
31:24	RO	-	Reserved	8'd0
23:12	-	-	Reserved	12'd1
11:0	R/W	P4_PVID	Port4 PVID setting	12'd1

PVIDC3: PVID Configuration 3 (offset: 0x4C)

Bits	Type	Name	Description	Initial value
31:12	RO	-	Reserved	20'd0
11:0	R/W	P6_PVID	Port6 PVID setting	12'd1

VLANI0: VLAN Identifier 0 (offset: 0x50)

Bits	Type	Name	Description	Initial value
31:24	RO	-	Reserved	8'd0
23:12	R/W	VID1	VLAN field Identifier for VLAN 1	12'd2
11:0	R/W	VID0	VLAN field Identifier for VLAN 0	12'd1

VLANI1: VLAN Identifier 1 (offset: 0x54)

Bits	Type	Name	Description	Initial value
31:24	RO	-	Reserved	8'd0
23:12	R/W	VID3	VLAN field Identifier for VLAN 3	12'd4
11:0	R/W	VID2	VLAN field Identifier for VLAN 2	12'd3

VLANI2: VLAN Identifier 2 (offset: 0x58)

Bits	Type	Name	Description	Initial value
31:24	RO	-	Reserved	8'd0
23:12	R/W	VID5	VLAN field Identifier for VLAN 5	12'd6
11:0	R/W	VID4	VLAN field Identifier for VLAN 4	12'd5

VLANI3: VLAN Identifier 3 (offset: 0x5C)

Bits	Type	Name	Description	Initial value
31:24	RO	-	Reserved	8'd0
23:12	R/W	VID7	VLAN field Identifier for VLAN 7	12'd8
11:0	R/W	VID6	VLAN field Identifier for VLAN 6	12'd7

VLANI4: VLAN Identifier 4 (offset: 0x60)

Bits	Type	Name	Description	Initial value
31:24	RO	-	Reserved	8'd0
23:12	R/W	VID9	VLAN field Identifier for VLAN 9	12'd10
11:0	R/W	VID8	VLAN field Identifier for VLAN 8	12'd9

VLANI5: VLAN Identifier 5 (offset: 0x64)

Bits	Type	Name	Description	Initial value
31:24	RO	-	Reserved	8'd0
23:12	R/W	VID11	VLAN field Identifier for VLAN 11	12'd12
11:0	R/W	VID10	VLAN field Identifier for VLAN 10	12'd11

VLANI6: VLAN Identifier 6 (offset: 0x68)

Bits	Type	Name	Description	Initial value
31:24	RO	-	Reserved	8'd0
23:12	R/W	vid13	VLAN field Identifier for VLAN 13	12'd14
11:0	R/W	vid12	VLAN field Identifier for VLAN 12	12'd13

VLANI7: VLAN Identifier 7 (offset: 0x6C)

Bits	Type	Name	Description	Initial value
31:24	RO	-	Reserved	8'd0
23:12	R/W	VID15	Identifier for VLAN 15	12'd16
11:0	R/W	VID14	Identifier for VLAN 14	12'd15

VMSC0: VLAN Member Port Configuration 0 (offset: 0x70)

Bits	Type	Name	Description	Initial value
30:24	R/W	VLAN_MEMSET_3	VLAN 3 member port	8'hff
22:16	R/W	VLAN_MEMSET_2	VLAN 2 member port	8'hff
15:8	R/W	VLAN_MEMSET_1	VLAN 1 member port	8'hff
7:0	R/W	VLAN_MEMSET_0	VLAN 0 member port	8'hff

VMSC1: VLAN Member Port Configuration 1 (offset: 0x74)

Bits	Type	Name	Description	Initial value
30:24	R/W	VLAN_MEMSET_7	VLAN 7 member port	8'hff
22:16	R/W	VLAN_MEMSET_6	VLAN 6 member port	8'hff
15:8	R/W	VLAN_MEMSET_5	VLAN 5 member port	8'hff
7:0	R/W	VLAN_MEMSET_4	VLAN 4 member port	8'hff

VMSC2: VLAN Member Port Configuration 2 (offset: 0x78)

Bits	Type	Name	Description	Initial value
30:24	R/W	VLAN_MEMSET_11	VLAN 11 member port	8'hff
22:16	R/W	VLAN_MEMSET_10	VLAN 10 member port	8'hff
15:8	R/W	VLAN_MEMSET_9	VLAN 9 member port	8'hff
7:0	R/W	VLAN_MEMSET_8	VLAN 8 member port	8'hff

VMSC3: VLAN Member Port Configuration 3 (offset: 0x7C)

Bits	Type	Name	Description	Initial value
30:24	R/W	VLAN_MEMSET_15	VLAN 15 member port	8'hff
22:16	R/W	VLAN_MEMSET_14	VLAN 14 member port	8'hff
15:8	R/W	VLAN_MEMSET_13	VLAN 13 member port	8'hff
7:0	R/W	VLAN_MEMSET_12	VLAN 12 member port	8'hff

POA: Port Ability (offset: 0x80)

Bits	Type	Name	Description	Initial value
31	RO	G1_LINK	Port 6 Link 1=up, 0=down	1'b0
30	RO	-	Reserved	1'b0
29:25	RO	LINK	Port 4 ~ port 0 Link 1=up, 0=down	5'b0

24:23	RO	G1_XFC	Flow Control of Port 6 1x = full duplex and Tx flow control ON x1= full duplex and Rx flow control ON 00 = flow control off (after AN or forced)	2'b0
22:21	RO	-	Reserved	2'b0
20:16	RO	XFC	Flow Control of PHY port 1 = full duplex and 802.3x flow control ON (after AN or forced)	5'b0
15:9	RO	DUPLEX	Port6 ~ port0 Duplex, 1= full duplex, 0=half duplex	7'h00
8:7	RO	G1_SPD	MII port Speed: 10: 1GHz, 01: 100M, 00: 10M	2'b0
6:5	RO	-	Reserved	2'b0
4:0	RO	SPEED	Port4 ~ port0 Speed: 1=100M, 0=10M	5'b0

FPA: Force Port4 ~ Port0 Ability (offset: 0x84)

Bits	Type	Name	Description	Initial value
31:27	R/W	FORCE_MODE	Port4 ~ port 0 force mode	5'd0
26:22	R/W	FORCE_LNK	Port 4 ~ port 0 PHY Link 1=up, 0=down	5'b0
21	RO	-	Reserved	1'd0
20:16	R/W	FORCE_XFC	Port 4 ~ port 0 Flow control of PHY port 1 = full duplex and 802.3x flow control ON	5'd0
15:13	RO	-	Reserved	3'd0
12:8	R/W	FORCE_DPX	Port4 ~ port0 Duplex, 1= full duplex, 0=half duplex	5'd0
7:5	RO	-	Reserved	3'd0
4:0	R/W	FORCE_SPD	Port4 ~ port0 Speed: 1=100M, 0=10M	5'b0

PTS: Port Status (offset: 0x88)

Bits	Type	Name	Description	Initial value
31:10	RO	-	Reserved	22'b0
9	RO	G1_TXC_STATUS	Port 6 TXC status port 6 TXC status, 1= error, no TXC	1'b0
8	RO	-	Reserved	1'b0
7	RO	-	Reserved	1'b0
6:0	RO	SECURED_ST	Security Status 1= has intruder coming if turn on the SA_secured mode, read clear	7'b0

SOCPC: SoC Port Control (offset: 0x8C)

Bits	Type	Name	Description	Initial value
31:26	RO	-	Reserved	6'b0
25	R/W	CRC_PADDING	CRC padding from CPU If this bit = 1, all packet from CPU will not append CRC and let LAN/WAN port to re-calculate and attach CRC.	1'b1
24:23	RO	-	Reserved	2'b0
22:16	R/W	DISBC2C PU	When this bit = 1, broadcast packets from LAN/WAN port(s) will not forward to CPU.	7'h7f
15	RO	-	Reserved	1'b0
14:8	R/W	DISMC2C PU	When this bit =1, multicast packets from ports will not forward to CPU.	7'h7f
7	RO	-	Reserved	1'b0

6:0	R/W	DISUN2C PU	When this bit is =1 , unknown packets from port(s) will not forward to CPU	7'h7f
-----	-----	------------	--	-------

POC1: Port Control 0 (offset: 0x90)

Bits	Type	Name	Description	Initial value
31:30	R/W	HASH_ADDR_SHIFT	Address table hashing algorithm option for member set index	2'b0
29	R/W	DIS_GMII_PORT_1	Disable port 6 1: port disable (if dumb mode, default = 0)	1'b1
28	-	-	Reserved	1'b1
27:23	R/W	DIS_PORT	Disable phy port 1: port disable (if dumb mode, default = 0)	5'h1f
22:16	R/W	DISRMC2 CPU	1: disable RMC packet to cpu	7'h0
15	RO	-	Reserved	1'b0
14:8	R/W	EN_FC	Enable pause flow control enable 802.3x flow control	7'h7f
7	RO	-	Reserved	1'b0
6:0	R/W	Reserved	Enable back pressure 1: enable back pressure (but need to qualify BP_mode)	7'h7f

POC1: Port Control 1 (offset: 0x94)

Bits	Type	Name	Description	Initial value
31:23	RO	-	Reserved	9'd0
22:16	R/W	BLOCKING_STATE	0: normal state 1: blocking state, forwarding rmc packet to cpu(need programming address table)	7'd0
15	RO	-	Reserved	1'd0
14:8	R/W	DIS_LRNING	Disable SA learning 0: enable SA learn	7'b0
7	RO	-	Reserved	1'd0
6:0	R/W	SA_SECURED_PORT	SA secured mode 0: don't care SA match, 1: the packets' SA need match, otherwise discard the packets Note: 1. have to set dis_learn and sa_secured at the same time.	7'b0

POC2: Port control 2 (offset: 0x98)

Bits	Type	Name	Description	Initial value
31	RO	-	Reserved	1'b0
30	R/W	G1_TXC_CHECK	Check the Port 6 TXC if no txc clock, then disable MII port 1: enable, check TXC	1'b0
29	-	-	Reserved	1'b0
28:23	RO	-	Reserved	6'b0
22:16	R/W	DIS_UC_PAUSE	1: switch will not consider pause frame when DA!=0180c20001 and unicast to CPU 0: switch will consider pause frame when DA!=0180c20001 but unicast to CPU,	7'b0
15	RO	-	Reserved	1'b0
14:8	R/W	ENAGING PORT	Port aging 1: enable aging, 0: disable aging that the MAC address is belong to programmed port(s)	7'h7f
7:0	R/W	UNTAG_EN	Remove VLAN tag field 1: enable VLAN tag field removal.	8'h0

SGC: Switch Global Control (offset: 0x9C)

Bits	Type	Name	Description	Initial value
31:29	RO	-	Reserved	3'b0
28:27	R/W	IGMP_RULE	IGMP Packet Forward Rule Per hash result from address table. If no match, 00: BC 01: to cpu 10: drop 11: reserved	2'b0
26:25	R/W	RMC_TB_FAULT_RULE	00: to all port(not include blocking state port) 01: to cpu 10: drop	2'b00
24:23	R/W	LED_FLASH_TIME	The Frequency Of LED Flash 00: 30ms, 01: 60ms, 10: 240ms, 11: 480ms	2'b0
22:21	R/W	BISH_TH	The Threshold Of Memory Bisshop 11:skip if fail 8 blocks, 0 00:skip if fail 16 (default, from pins) 01:skip if fail 48 10:skip if fail 64	2'b0
20	RO	BISH_DIS	Build In Self Hop 0: enable skip function (default, from pin)	1'b0
19:18	R/W	BP_MODE	Back Pressure Mode 00: disable 01: BP jam, the jam number is set by bp_num 10: BP jamALL, jam packet until the BP condition is released(default), 11: BP carrier, use carrier insertion to do back pressure	2'b10
17:16	RO	-	Reserved	2'b0
15:12	R/W	BP_JAM_CNT	Back Pressure Jam Number the consecutive jam time when back pressure, default 10 packet jam then one no-jam	4'b1010
11	R/W	DISABLE TX BACKOFF	Disable The Collision Back Off Timer 1: re-transmit immediately after collision,	1'b0
10:9	R/W	ADDRESS_HASH_ALG	MAC Address Hashing Algorithm 00: direct mode, using last 10-bit as hashing address 01: XOR48 mode 10: XOR32 mode, 11:reserved	2'b0
8	R/W	DIS_PKT_TX_ABORT	1: Disable collision 16 packet abort and late collision abort 0: enable both abort	1'b1
7:6	R/W	PKT_MAX_LEN	Maximum Packet Length 00: 1536, 01: 1518, 10: 1522, 11: reserved	2'b0
5:4	R/W	BC_STORM_PREV	Broadcast Storm Prevention 00: disable , BC will be blocked, if (01: 64 , 10: 48, 11: 32) BC blocks in queue	2'b0
3:0	R/W	AGING INTERVAL	Aging Timer 0000: disable age, 1xxx: fast age 0001: 300sec, 0010: 600 0111: 38400sec	4'd1

STRT: Switch Reset (offset: 0xA0)

Bits	Type	Name	Description	Initial value
31:0	WO	Reset_SW	Reset switch engine, data, address, link memory, cpu port and ahb interface when write.	32'b0

LEDP0: LED Port0 (offset: 0xA4)

Bits	Type	Name	Description	Initial value
31:4	RO	-	Reserved	28'd0
3:0	RW	P0_LED	port0 LED state, default = link/activity 4'b0000: link 4'b0001: 100M speed 4'b0010: duplex 4'b0011: activity 4'b0100: collision 4'b0101: link/activity 4'b0110: duplex/collision 4'b0111: 10M speed/activity 4'b1000: 100M speed/activity	4'b0101

LEDP1: LED Port 1 (offset: 0xA8)

Bits	Type	Name	Description	Initial value
31:4	RO	-	Reserved	28'b0
3:0	RW	P1_LED	Port1 LED state, default = link/activity	4'b0101

LEDP2: LED Port2 (offset: 0xAC)

Bits	Type	Name	Description	Initial value
31:4	RO	-	Reserved	28'b0
3:0	RW	P2_LED	Port2 LED state, default = link/activity	4'b0101

LEDP3: LED Port3 (offset: 0xB0)

Bits	Type	Name	Description	Initial value
31:4	RO	-	Reserved	28'b0
3:0	RW	P3_LED	Port3 LED state, default = link/activity	4'b0101

LEDP4: LED Port4 (offset: 0xB4)

Bits	Type	Name	Description	Initial value
31:4	RO	-	Reserved	28'b0
3:0	RW	P4_LED	Port4 LED state, default = link/activity	4'b0101

WDTR: Watch Dog trigger Reset (offset: 0xB8)

Bits	Type	Name	Description	Initial value
31:8	RO	-	Reserved	24'b0
7:0	RW	BUF_STARV_TH	Buffer starvation threshold Switch will interrupt CPU when the global queue block counts are less than the threshold for 3 seconds.	8'd30

DES: Debug Signal (offset: 0xBC)

Bits	Type	Name	Description	Initial value
15:0	RO	DEBUG_SIGNAL	Port 5 debug signal	16'b0

PCR0: PHY Control Register 0 (offset: 0xC0)

Bits	Type	Name	Description	Initial value
31:16	RW	WT_NWAY_DATA	The data be written into the PHY	17'b0
15	RO	-	Reserved	1'b0
14	RW	RD_PHY_CMD	Read command, self_clear	1'b0
13	RW	WT_PHY_CMD	Write command, self_clear	1'b0
12:8	RW	CPU_PHY_REG_ADDR	PHY register address	5'b0
7:5	RO	-	Reserved	3'b0
4:0	RW	CPU_PHY_ADDR	PHY address	5'b0

PCR1: PHY control register 1 (offset: 0xC4)

Bits	Type	Name	Description	Initial value
31:16	RO	RD_DATA	The Read Data	15'b0

15:2	RO	-	Reserved	14'b0
1	RO	RD_RDY	Read operation is complete and data is ready, read clear	1'b0
0	RO	WT_DONE	Write operation is done, read clear	1'b0

FPA: Force Port 5 ~Port 6 ability (offset: 0xC8)

Bits	Type	Name	Description	Initial value
31:16	RO	-	Reserved	16'h0550
15:14	R/O	-	Reserved	2'b0
13	R/W	FORCE_RGMII_LINK1	Force port 6 link	1'b0
12	-	-	Reserved	1'b0
11	R/W	FORCE_RGMII_EN1	Force port 6 enable	1'b0
10	-	-	Reserved	1'b0
9:8	R/W	FORCE_RGMII_XFC1	Force port 6 flow control ability 1x: for Tx, x1: for Rx	2'b11
7:6	-	-	Reserved	2'b0
5	R/W	FORCE_RGMII_DPX1	Force port 6 duplex	1'b1
4	-	-	Reserved	1'b0
3:2	R/W	FORCE_RGMII_SPD1	Force port 6 speed 1x: 1GHz, 01: 100MHz, 00: 10MHz	2'b10
1:0	-	-	Reserved	2'b0

FCT2: Flow Control Threshold 2 (offset: 0xCC)

Bits	Type	Name	Description	Initial value
31:18	RO	-	Reserved	14'd0
17:13	R/W	MUST_DROP_RLS_TH	If the global queue pointer higher than the threshold. The must drop condition will be released.	5'd5
12:8	R/W	MUST_DROP_SET_TH	If the global queue pointer reach must drop. All incoming packets have to be dropped.	5'd3
7:6	RO	-	Reserved	2'b0
5:0	R/W	MC_PER_PORT_TH	MC packets per port threshold.	6'd12

QSS0: Queue_Status_0 (offset: 0xD0)

Bits	Type	Name	Description	Initial value
31:24	RO	-	Reserved	8'b0
23:15	RO	BE_CNT_R	Link control best effort block counter monitor	9'b0
14:5	RO	BK_CNT_R	Link control background block counter monitor	10'b0
4:0	R/W	SEE_CNT_PORT_SEL	Link control see port counter selection control	5'b0

QSS1: Queue_Status_1 (offset: 0xD4)

Bits	Type	Name	Description	Initial value
31:18	RO	-	Reserved	14'b0
17:9	RO	VO_CNT_R	Link control best effort block counter monitor	9'b0
8:0	RO	CL_CNT_R	Link control background block counter monitor	9'b0

DEC: Debug Control (offset: 0xD8)

Bits	Type	Name	Description	Initial value
31:24	R/W	BRIDGE_IPG	Bridge IPG byte count	8'd64
23:6	RO	-	Reserved	18'd0
5:3	R/W	-	Reserved	3'b0
2:0	RO	-	Reserved	3'd0

MTI: Memory Test Information (offset: 0xDC)

Bits	Type	Name	Description	Initial value
31:16	RO	-	Reserved	16'b0
15:7	RO	SKIP_BLOCKS	Skip block counter	9'bx

6	RO	SW_MEM_TEST_DONE	Switch memory test done	1'bx
5	RO	LK_RAM_TEST_DONE	Link ram test done	1'bx
4	RO	LK_RAM_TEST_FAIL	Link ram test fail	1'bx
3	RO	AT_RAM_TEST_DONE	Address table ram test done	1'bx
2	RO	AT_RAM_TEST_FAIL	Address table ram test fail	1'bx
1	RO	DT_RAM_TEST_DONE	Data buffer ram test done	1'bx
0	RO	DT_RAM_TEST_FAIL	Data buffer ram test fail	1'bx

PPC: Port 6 Packet Counter (offset: 0xE0)

Bits	Type	Name	Description	Initial value
31:16	RO	SW2FE_CNT	Switch to frame engine packet counter	16'b0
15:0	RO	FE2SW_CNT	Frame engine to switch packet counter	16'b0

SGC2: Switch Global Control 2 (offset: 0xE4)

Bits	Type	Name	Description	Initial value
31	R/W	-	Reserved	1'b0
30	R/W	SW2FE_WL_FC_EN	Switch to Frame engine WAN/LAN port flow control enable 1: Switch to Frame engine flow control is decided by WAN/LAN port congestion independently. 0: Switch to Frame engine flow control is decided by any port congestion	1'b0
29:24	R/W	LAN_PMAP	Lan port bit map 1:Lan port 0:Wan port	6'b0
23	RO	-	Reserved	9'b0
22:16	R/W	TX_CPU_TPID_BIT_MAP	Transmit CPU TPID(810x) port bit map	7'b0
15:12	RO	-	Reserved	4'b0
11	R/W	ARBITER_LAN_EN	memory arbiter only for P0~P4 enable 0: normal 1: memory arbiter only for P0~P4.	1'b0
10	R/W	CPU_TPID_EN	CPU TPID(81xx) enable 0: disable. CPU TPID=8100 1: enable. CPU TPID=810x.	1'b0
9:7	RO	-	Reserved	3'b0
6:0	R/W	DOUBLE_TAG_EN	Insert double tag field 1: enable double tag field 0: disable the double tag field.	7'b0

POPC: Port 0 Packet Counter (offset: 0xE8)

Bits	Type	Name	Description	Initial value
31:16	RO	BAD_PKT_CNT0	Port 0 receive bad packet counter	16'b0
15:0	RO	GOOD_PKT_CNT0	Port 0 receive good packet counter	16'b0

P1PC: Port 1 Packet Counter (offset: 0xEC)

Bits	Type	Name	Description	Initial value
31:16	RO	BAD_PKT_CNT1	Port 1 receive bad packet counter	16'b0
15:0	RO	GOOD_PKT_CNT1	Port 1 receive good packet counter	16'b0

P2PC: Port 2 Packet Counter (offset: 0xF0)

Bits	Type	Name	Description	Initial value
31:16	RO	BAD_PKT_CNT2	Port 2 receive bad packet counter	16'b0
15:0	RO	GOOD_PKT_CNT2	Port 2 receive good packet counter	16'b0

P3PC: Port 3 Packet Counter (offset: 0xF4)

Bits	Type	Name	Description	Initial value
31:16	RO	BAD_PKT_CNT3	Port 3 receive bad packet counter	16'b0
15:0	RO	GOOD_PKT_CNT3	Port 3 receive good packet counter	16'b0

P4PC: Port 4 packet counter (offset: 0xF8)

Bits	Type	Name	Description	Initial value
31:16	RO	BAD_PKT_CNT4	Port 4 receive bad packet counter	16'b0
15:0	RO	GOOD_PKT_CNT4	Port 4 receive good packet counter	16'b0

P5PC: Port 5 packet counter (offset: 0xFC)

Bits	Type	Name	Description	Initial value
31:16	RO	-	Reserved	16'b0
15:0	RO	-	Reserved	16'b0

3.18.4 MII control register

These registers can be accessed indirectly by PCR0 (PHY Control Register 0) and PCR1. Among them, PHY reg0~1 and 4~6 are unique for each port. PHY reg2 ~ 3 are common for all 5 ports.

Legend:

SC: Self-clearing, RC: Read-clearing

LL: Latching Low, LH: Latching High

R/W: Read/write, RO: Read-Only

CR Address:00(d00) Reset State: 3100

Bit	Read/Write	Name	Description	Default
15	R/ W; SC	MR_MAIN_RESET	1=Reset: 0=Normal, reset all digital logic, except phy_reg	1'h0
14	R/W	LOOPBACK_MII	Mii loop back	1'h0
13	R/W	FORCE_SPEED	1 = 100Mbps: 0=10Mbps, when mr_autoneg_enable = 1'b0	1'h1
12	R/W	MR_AUTONEG_ENABLE	1= Enabled: 0=Normal	1'h1
11	R/W	POWERDOWN	phy into power down (power down analog TX analog RX, analog AD)	1'h0
10	RO	-	Reserved	1'h0
9	R/W; SC	MR_RESTART_NEGOTIATION	1 = Restart Auto-Negotiation: 0 = Normal	1'h0
8	R/W	FORCE_DUPLEX	1 = Full Duplex: 0 = Half Duplex, when mr_autoneg_enable = 1'b0	1'h1
7:0	RO	-	Reserved	8h00

MII status register

CR Address:01(d01) Reset State: 7849

Bit	Read/Write	Name	Description	Default
15	RO	100 BASE T4	Not supported	1'h0
14	RO	100BASE-X Full Duplex	1 = PHY is 100BASE-X full duplex capable 0 = PHY is not 100BASE-X full duplex capable	1'h1

13	RO	100BASE-X Half Duplex	1 = PHY is 100BASE-X half duplex capable 0 = PHY is not 100BASE-X half duplex capable	1'h1
12	RO	10Mbps/s Full Duplex	1 = PHY is 10Mbps/s Full duplex capable 0 = PHY is not 10Mbps/s Full duplex capable	1'h1
11	RO	10 Mb/s Half Duplex	1 = PHY is 10Mbps/s Half duplex capable 0 = PHY is not 10Mbps/s Half duplex capable	1'h1
10	RO	100BASE-T2 full duplex	Not supported	1'h0
9	RO	100BASE-T2 half duplex	Not supported	1'h0
8:7	RO	-	Reserved	2'h0
6	RO	MF Preamble Suppression	1 = PHY can accept management frames with preamble suppression 0 = PHY cannot accept management frames with preamble suppression	1'h1
5	RO	mr_autoneg_complete	1 = auto-negotiate completed, 0 = auto-negotiate incomplete	1'h0
4	RO	-	Reserved	1'h0
3	RO	Autoneg Ability	1 = PHY can auto-negotiate, 0 = PHY cannot auto-negotiate	1'h1
2	RO/LL	Link Status	1 = link is up, 0 = link is down	1'h0
1	RO/LH; RC	Jabber Detect	1 = jabber condition detected	1'h0
0	RO	Extended Capability	1=extended register capabilities, 0=basic register set capabilities only	1'h1

PHY identifier register

CR Address:02(d02) Reset State: 00c3

Bit	Read/Write	Name	Description	Default
15:0	RO	PHY_ID[31-16]	OUI (bits 3-18). Ralink OUI =000C43	16'h00c3

PHY version register

CR Address:03(d03) Reset State: 0800

Bit	Read/Write	Name	Description	Default
15:10	RO	PHY_ID[15-10]	OUI (bits 19-24)	6'h02
9:4	RO	PHY_ID[9-4]	Manufacturer's Model Number (bits 5-0)	6'h00
3:0	RO	PHY_ID[3-0]	Revision Number (bits3-0); Register 3, bit 0 is LS bit of PHY Identifier	4'h0

Auto-Negotiation advertisement register

CR Address:04(d04) Reset State: 05e1

Bit	Read/Write	Name	Description	Default
15	RO	Next Page Enable	1=Set to use Next Page: 0=Not to use Next Page	1'h0
14	RO	-	Reserved	1'h0
13	R/W	Remote Fault Enable	1 = Auto Negotiation Fault Detected 0 = No Remote Fault	1'h0
12:11	RO	Not Implemented	Technology Ability A7-A6	2'h0
10	R/W	Pause	Technology Ability A5	1'h1

9	RO	Not Implemented	Technology Ability A4	1'h0
8	R/W	100Base-TX Full Duplex Capable	1 = Capable of Full Duplex 0 = Not Capable	1'h1
7	R/W	100 Base-TX Half Duplex Capable	1 = Capable of Half Duplex 0 = Not Capable	1'h1
6	R/W	10 Base-T Full Duplex Capable	1 = Capable of Full Duplex 10BASE-T 0 = Not Capable	1'h1
5	R/W	10 Base-T Half Duplex Capable	1 = Capable of Half Duplex 10BASE-T 0 = Not Capable	1'h1
4:0	R/W	Selector Field	Identifies type of message	5'h01

Auto-Negotiation Link partner (LP) ability register

CR Address:05(d05) Reset State: 0000

Bit	Read/Write	Name	Description	Default
15	RO	Next Page	1=Link Partner is requesting Next Page function 0=Base Page is requested.	1'h0
14	RO	Acknowledge	1= Link partner acknowledge Received Successfully 0 =Not Received	1'h0
13	RO	Remote Fault	1 = Auto Negotiation Fault Detected 0 = No Remote Fault	1'h0
12:1	RO	Not implemented	Technology Ability A7-A6	2'h0
1				
10	RO	Pause	Technology Ability A5	1'h0
9	RO	Not Implemented	Technology Ability A4	1'h0
8	RO	100Base-TX Full Duplex Capable	1 = Capable 0 = Not Capable	1'h0
7	RO	100 Base-TX Half Duplex Capable	1 = Capable 0 = Not Capable	1'h0
6	RO	10 Base-T Full Duplex Capable	1 = Capable 0 = Not Capable	1'h0
5	RO	10 Base-T Half Duplex Capable	1 = Capable 0 = Not Capable	1'h0
4:0	RO	Selector Field	Identifies type of message	5'h00

Auto-Negotiation expansion register

CR Address:06(d06) Reset State: 0000

Bit	R/W/Type	Name	Description	Default
15:5	RO	RESERVED	No Meaning	11'h0
4	RO/LH; RC	Parallel Detection Fault	1 = Local Device Parallel Detection Fault 0 = No fault detected	1'h0
3	RO	Link Partner Next Page Able	1 = Link Partner is Next Page Able 0 = Link Partner is not Next Page Able	1'h0
2	RO	mr_np_able	1 = Local device is Next Page Able 0 = Local device is not Next Page Able	1'h0
1	RO/LH; RC	Page Received	1 = A New Page has been received 0 = A New Page has not been received	1'h0
0	RO	Link Partner Auto-negotiation Able	1 = Link Partner is Auto-negotiation able 0 = Link Partner is not Auto-negotiation able	1'h0

3.18.5 Flow control settings

3.18.5.1 Flow control settings

For both FE and GE ports, flow control enable/disable is decided by:

1. Force mode is the highest priority
 - 1.1 GE ports use FPA: Force Port 5 ~ Port 6 ability (offset: 0xC8)
 - [11:10] Enable port 6 or 5 force mode
 - [9:8] Port 6 flow control ability (Support asymmetric flow control [9]: TX [8]: RX)
 - [7:6] Port 5 flow control ability
 - 1.2 FE ports use FPA: Force Port 4 ~ Port 0 Ability (offset: 0x84)
 - [31:27] Enable port 4 ~ 0 force mode
 - [26:22] Port 4 ~ 0 flow control ability (Only support symmetric flow control)
2. If the force mode is disabled, then use the flow control status after auto-negotiation. But there is one exception for flow control: when POC1: Port Control 0 (offset: 0x90) [14:8] "EN_FC" pause flow control is disabled, then flow control will be disabled without regard to the AN result.
 - (For GE ports, Port 5 or 6, EN_FC[port_num] = 0 will disable both TX and RX flow control)No matter using force or AN mode, the final flow control enable/disable value will show on POA: Port Ability (offset: 0x80) [24:16] for port 0 ~ 6
3. Another exception on PFC0: Priority flow control – 0 (offset: 0x10) [23:16] Turn off flow control, For Q3 traffic, the user can use this register to turn off the flow control.

3.18.5.2 VID and Tagging

3.18.5.2.1 VID and VLAN member set

RT3050 supports 16 VLANs. It can be configured to identify any 16 out of 4096 possible VIDs. These 16 VIDs could be configured by setting VIDx (X=0~15) registers. To configure the member set ports of a given VLAN, one can set the VLAN_MEMSET_x (x=0~15) register. Each bit of the VLAN_MEMSET_x register corresponds to the associated port. For example, to configure port #1 and port #3 as the member ports of VLAN 5, one can set VLAN_MEMSET_5 as 8'b00001010.

3.18.5.2.2 Tag and Untag

There is a per port register to configure the egress tag and untag setting. If one does not want a VLAN tagged frame transmitted from a given port x, he could set UNTAG_EN[x] = 1; If one wants VLAN tagged frame transmitted from port y, he could set UNTAG_EN[y] = 0. RT3050 supports VLAN tag/untag by per egress port basis. It does not support per VLAN per port basis.

3.18.5.2.3 Port VID

There is per port P_x_PVID register to support PVID. The P_x_PVID is assigned to an incoming frame which is untagged or priority tagged (i.e. VID filed = 0).

3.18.5.2.4 Double Tag

RT3050 supports double VLAN tags by setting a per ingress port register – DOUBLE_TAG_EN[x]. When RT3050 receives a frame from a port with DOUBLE_TAG_EN = 1, it will ignore the VLAN tag filed, if any, and insert the associated PVID in front of the frame after the MAC SA field. Then, it will go on the frame forwarding decision based on this PVID. When this frame is finally be transmitted to an egress port with UNTAG_EN=0, the egress packet will be double VLAN tagged if its incoming format is single VLAN tag; it will be single VLAN tagged if its incoming format is non-VLAN tagged. Please see the following figure for some examples.

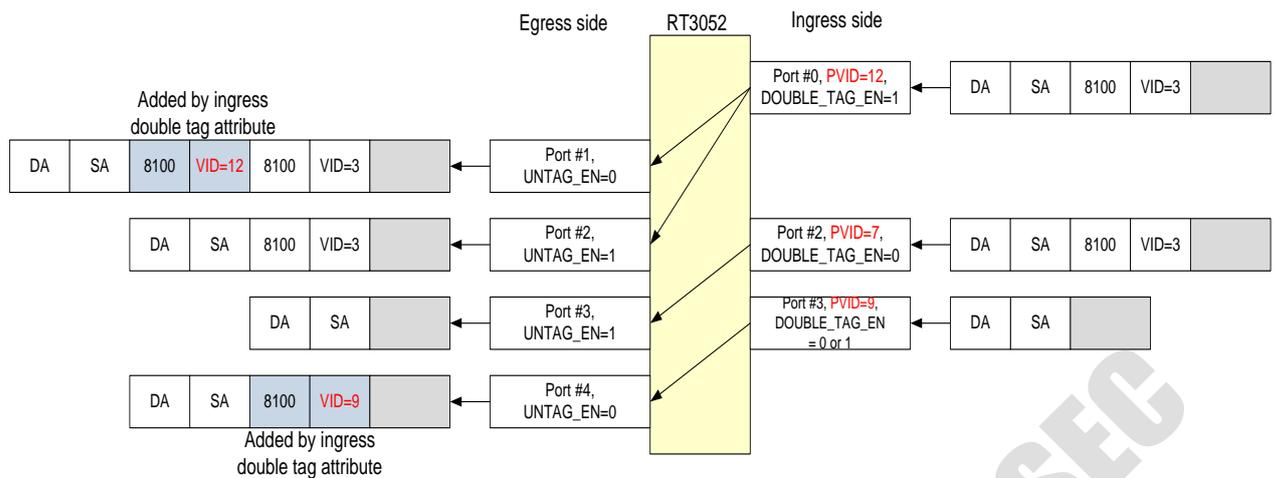

Fig. 3-18-2 Double Tag

3.18.5.2.5 Special Tag

In order to let the recipient (e.g. RT3050 internal CPU or external 3rd party CPU) know the incoming port number of a received frame, a special tag is supported to rewrite the TPID (0x8100) filed with the incoming port number. The format of this rewritten TPID is: 810x, where x specifies the incoming port number. To enable this feature, one should set CPU_TPID_EN=1 first and specify output ports that need incoming port number to be carried by TPID by setting the associated ports in TX_CPU_TPID_BIT_MAP [6:0]. Please be noted, this special tag feature is a supplement to the existing VLAN tag feature. If the egress frame does not have VLAN tag, there is no way for RT3050 to put incoming port number into the modified TPID field. If the egress frame is double VLAN tagged, the special tag applies to the outer VLNA tag only. Please see the following figure for some examples.

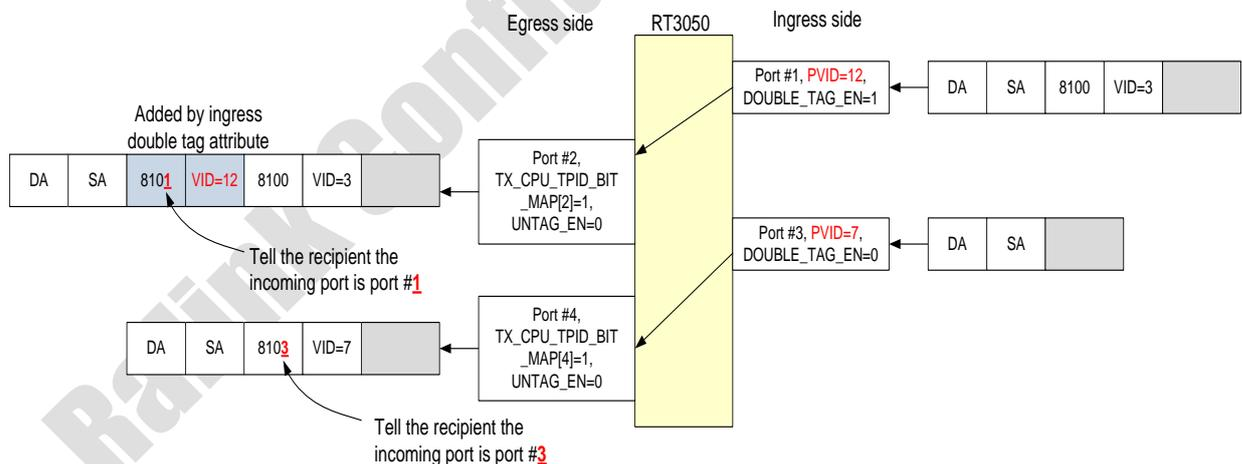

Fig. 3-18-3 Special Tag

3.18.5.3 Packet Classification, QoS, Scheduling and Buffer control

RT3050 supports 4 CoS queues per egress port. When a frame is received, it is classified by IP DSCP, 802.1p tag and incoming port priority. The classify sequence is 802.1p tag first, then IP DSCP, and finally the incoming port priority. To enable IP DSCP classification for port x, one has to set EN_TOS[x] to 1; to enable 802.1p tag classification for port x, one has to set EN_VLAN[x] to 1. If both EN_TOS[x] and EN_VLAN[x] are zero or could not be applied (for non-IP or non-VLAN frames), frame will be classified by the PORT_PRIx register. The IP DSCP and 802.1p user priority to CoS queue mapping are specified by the following tables:

IP DSCP (decimal value)	CoS Queue Mapping
0~15	BK_q
16~31	BE_q
32~47	CL_q
48~63	VO_q

802.1p priority (decimal value)	CoS Queue Mapping
1, 2	BK_q
0, 3	BE_q
4, 5	CL_q
6, 7	VO_q

At the egress side, there is a SP/WRR scheduler for each output port to schedule the frame transmission opportunity. One can assign the weight for each of the VO/CL/BE/BK queues to specify the service ratio. It also supports a mixed schedule mode to treat VO queue as the strict priority by assigning its weight (VO_NUM) to zero.

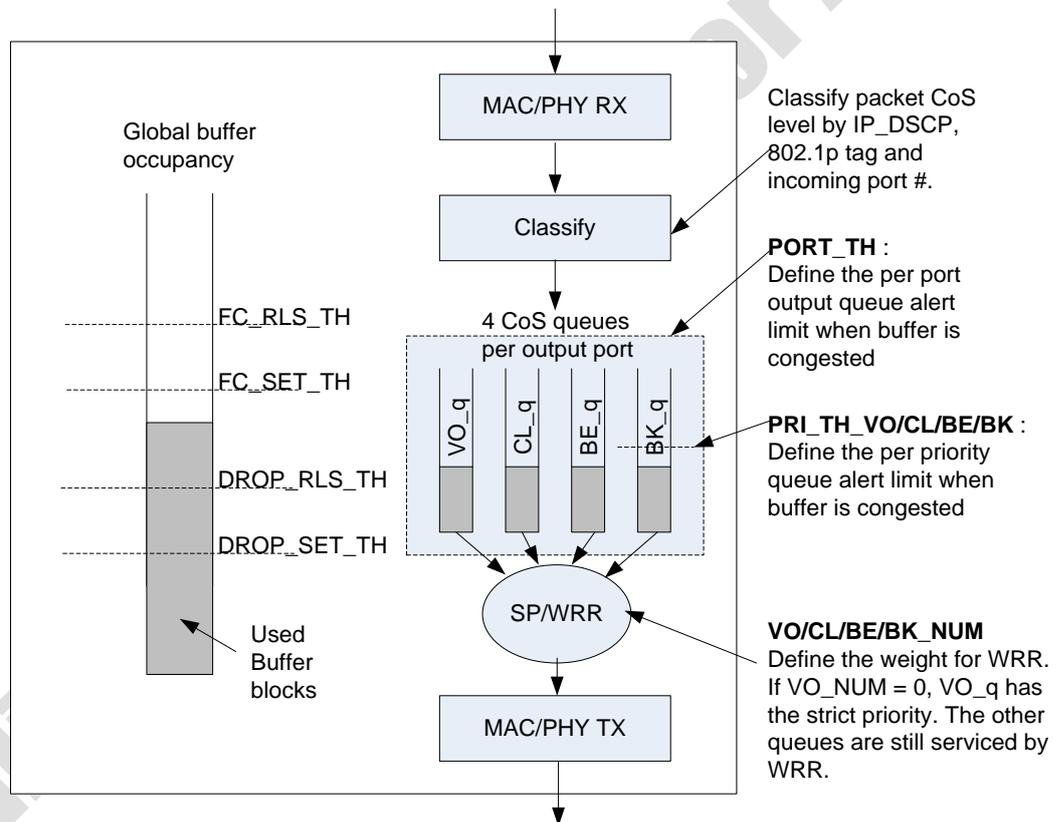

Fig. 3-18-4 Packet Classification, QoS, Scheduling and Buffer control

To support QoS-aware flow control, there is a global per CoS queue threshold setting to define the alert threshold when global packet buffer is getting congested. When the global buffer block count is lower than FC_SET_TH, an incoming frame will trigger a pause_ON frame to be transmitted if the PORT_TH of the destination port and PRI_TH_xx (xx = VO or CL or BE or BK) are both reached. By this sophisticated buffer control mechanism, the high priority traffic (e.g. VoIP) will not get dropped or paused if it is put in strict priority VO_q and its source rate is controlled.

The above description for QoS-aware flow control could be worked even well if we turn on SW2FE_WL_FC_EN (Switch to Frame Engine WAN-LAN flow control) for one-armed router application.

Since there is only a single GE port connecting the frame engine and the embedded Ethernet switch, the traditional 802.3x pause mechanism might block all frames from CPU to the Ethernet switch regardless of frame's destination (LAN or WAN). In other words, there will be HOL (Head-of-Line blocking) in this one-armed router case. To relieve the HOL, one could tell the Ethernet switch which ports are LAN ports by specifying the ports into LAN_PMAP register. Together with separated LAN/WAN GDMA in the frame engine, a better QoS-aware flow control could be supported.

Ralink Confidential for ASEC

3.19 USB OTG Controller & PHY

3.19.1 Features

- Support USB Host/Device Dual mode
- Complies with the On-The-Go Supplement to the USB 2.0 Specification (Revision 1.0a)

- Operates in High-Speed (HS, 480-Mbps), Full-Speed (FS, 12-Mbps) and Low-Speed (LS, 1.5-Mbps) modes
- Supports up to 4 bidirectional endpoints, including control endpoint 0
- Supports up to 4 host channels.
- Supports a generic root hub
- Includes automatic ping capabilities
- Supports Internal DMA modes
- Includes USB power management features
- Includes power-saving features (clock gating, two power rails for advanced power management)
- Supports packet-based, Dynamic FIFO memory allocation for endpoints for small FIFOs, and flexible, efficient use of RAM provides support to change an endpoint's FIFO memory size during transfers

3.19.2 Block Diagram

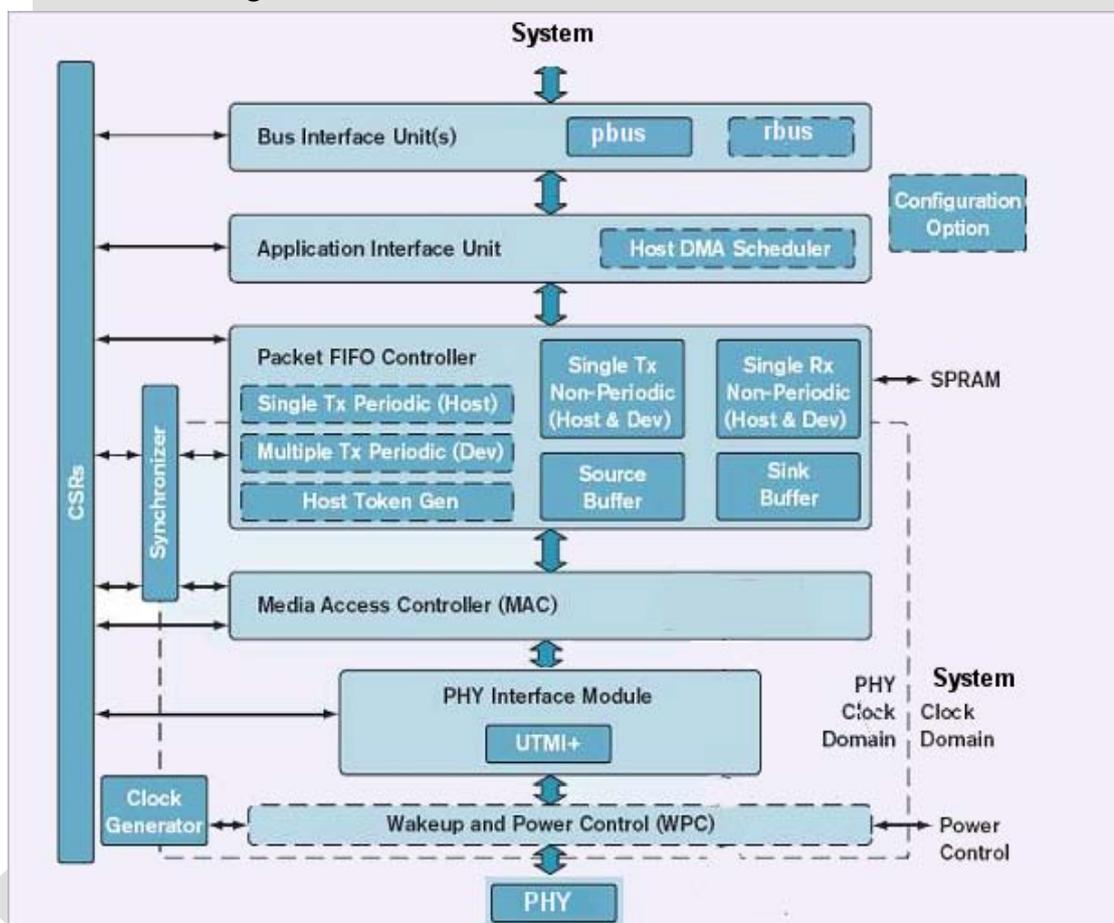

Fig. 3-19-1 USB OTG Controller & PHY Block Diagram

3.19.3 Register Description (base: 0x101C.0000)

The following table defines the parameters used in the USB OTG block. Please refer to it when reading the register description session after it

Parameter name	Value	Parameter name	Value
OTG_AHB_CLK_PERIOD	10000	OTG_NUM_HOST_CHAN	4
OTG_ARCHITECTURE	2	OTG_NUM_IN_EPS	3

OTG_DFIFO_DEPTH	4096	OTG_NUM_PERIO_EPS	0
OTG_DFIFO_DYNAMIC	1	OTG_PACKET_COUNT_WIDTH	10
OTG_EN_A_VALID_FILTER	1	OTG_PERIO_TX_QUEUE_DEPTH	8
OTG_EN_B_VALID_FILTER	1	OTG_RM_OPT_FEATURES	1
OTG_EN_DED_TX_FIFO	1	OTG_RX_DFIFO_DEPTH	4096
OTG_EN_IDDIG_FILTER	1	OTG_RX_DFIFO_DEPTH	4096
OTG_EN_PERIO_HOST	1	OTG_SINGLE_POINT	0
OTG_EN_PWROPT	1	OTG_SYNC_CLOCKS	0
OTG_EN_SESSIONEND_FILTER	1	OTG_SYNC_RESET_TYPE	0
OTG_EN_VBUSVALID_FILTER	1	OTG_TOKEN_QUEUE_DEPTH	8
OTG_EP_DIR_1	0	OTG_TRANS_COUNT_WIDTH	19
OTG_EP_DIR_2	0	OTG_TX_DINEP_DFIFO_DEPTH_0	512
OTG_EP_DIR_3	0	OTG_TX_DINEP_DFIFO_DEPTH_1	512
OTG_FSPHY_INTERFACE	0	OTG_TX_DINEP_DFIFO_DEPTH_2	512
OTG_HSPHY_DWIDTH	1	OTG_TX_DINEP_DFIFO_DEPTH_3	256
OTG_HSPHY_INTERFACE	1	OTG_TX_DPERIO_DFIFO_DEPTH_1	768
OTG_I2C_INTERFACE	0	OTG_TX_DPERIO_DFIFO_DEPTH_2	768
OTG_INST_DSYNC_FLOPS	0	OTG_TX_DPERIO_DFIFO_DEPTH_3	768
OTG_INVERT_AHB_CLK	0	OTG_TX_HNPERIO_DFIFO_DEPTH	1024
OTG_MIN_AHB_FREQ	100	OTG_TX_HPERIO_DFIFO_DEPTH	1024
OTG_MIN_AHB_FREQ_LESSTHAN_60	1	OTG_TX_NPERIO_DFIFO_DEPTH	1024
OTG_MODE	0	OTG_ULPI_CARKIT	0
OTG_NPERIO_TX_QUEUE_DEPTH	8	OTG_USERID	32'h12345678
OTG_NUM_CRL_EPS	0	OTG_VENDOR_CTL_INTERFACE	0
OTG_NUM_EPS	3	PHY_INST	0

Table 3-19-1 Parameter value

GOTGCTL: OTG Control and Status Register (offset: 0x000)

Bits	Type	Name	Description	Mode	Initial value
31:20	-	-	Reserved	-	12'h0
19	RO	BsesVld	B-Session Valid Indicates the Device mode transceiver status. • 1'b0: B-session is not valid. • 1'b1: B-session is valid. In OTG mode, you can use this bit to determine if the device is connected or disconnected.	Device only	1'b0
18	RO	AsesVld	A-Session Valid Indicates the Host mode transceiver status. • 1'b0: A-session is not valid • 1'b1: A-session is valid	Host only	1'b0
17	RO	DbncTime	Long/Short Debounce Time Indicates the debounce time of a detected connection. • 1'b0: Long debounce time, used for physical connections (100 ms + 2.5 μ s) • 1'b1: Short debounce time, used for soft connections (2.5 μ s)	Host only	1'b0
16	RO	ConIDSts	Connector ID Status Indicates the connector ID status on a connect event. • 1'b0: The DWC_otg core is in A-Device mode • 1'b1: The DWC_otg core is in B-Device mode	Host and Device	1'b0
15:12	-	-	Reserved	-	4'b0

11	R/W	DevHNPEn	Device HNP Enabled The application sets this bit when it successfully receives a SetFeature.SetHNPEnable command from the connected USB host. <ul style="list-style-type: none"> • 1'b0: HNP is not enabled in the application • 1'b1: HNP is enabled in the application 	Device only	1'b0
10	R/W	HstSetHNPEn	Host Set HNP Enable The application sets this bit when it has successfully enabled HNP (using the SetFeature.SetHNPEnable command) on the connected device. <ul style="list-style-type: none"> • 1'b0: Host Set HNP is not enabled • 1'b1: Host Set HNP is enabled 	Host only	1'b0
9	R/W	HNPReq	HNP Request The application sets this bit to initiate an HNP request to the connected USB host. The application can clear this bit by writing a 0 when the Host Negotiation Success Status Change bit in the OTG Interrupt register (GOTGINT.HstNegSucStsChng) is set. The core clears this bit when the HstNegSucStsChng bit is cleared. <ul style="list-style-type: none"> • 1'b0: No HNP request • 1'b1: HNP request 	Device only	1'b0
8	RO	HstNegScs	Host Negotiation Success The core sets this bit when host negotiation is successful. The core clears this bit when the HNP Request (HNPReq) bit in this register is set. <ul style="list-style-type: none"> • 1'b0: Host negotiation failure • 1'b1: Host negotiation success 	Device only	1'b0
7:2	-	-	Reserved	-	4'h0
1	R/W	SesReq	Session Request The application sets this bit to initiate a session request on the USB. The application can clear this bit by writing a 0 when the Host Negotiation Success Status Change bit in the OTG Interrupt register (GOTGINT.HstNegSucStsChng) is set. The core clears this bit when the HstNegSucStsChng bit is cleared. If you use the USB 1.1 Full-Speed Serial Transceiver interface to initiate the session request, the application must wait until the VBUS discharges to 0.2 V, after the B-Session Valid bit in this register (GOTGCTL.BSesVld) is cleared. This discharge time varies between different PHYs and can be obtained from the PHY vendor. <ul style="list-style-type: none"> • 1'b0: No session request • 1'b1: Session request 	Device only	1'b0
0	RO	SesReqScs	Session Request Success The core sets this bit when a session request initiation is successful. <ul style="list-style-type: none"> • 1'b0: Session request failure • 1'b1: Session request success 	Device only	1'b0

GOTGCTL: OTG Interrupt Register (offset: 0x004)

Bits	Type	Name	Description	Mode	Initial value
------	------	------	-------------	------	---------------

31:20	-	-	Reserved	-	12'h0
19	R_SS_WC	DbnceDone	Debounce Done The core sets this bit when the debounce is completed after the device connects. The application can start driving USB reset after seeing this interrupt. This bit is only valid when the HNP Capable or SRP Capable bit is set in the Core USB Configuration register (GUSBCFG.HNPCap or GUSBCFG.SRPCap, respectively).	Host only	1'b0
18	R_SS_WC	ADevTOUTChg	A-Device Timeout Change The core sets this bit to indicate that the A-device timed out while waiting for the B-device to connect.	Host and Device	1'b0
17	R_SS_WC	HstNegDet	Host Negotiation Detected The core sets this bit when it detects a host negotiation request on the USB.	Host and Device	1'b0
16:10	-	-	Reserved	-	7'b0
9	R_SS_WC	HstNegSucStsChng	Host Negotiation Success Status Change The core sets this bit on the success or failure of a USB host negotiation request. The application must read the Host Negotiation Success bit of the OTG Control and Status register (GOTGCTL.HstNegScs) to check for success or failure.	Host and Device	1'b0
8	R_SS_WC	SesReqSucStsChng	Session Request Success Status Change The core sets this bit on the success or failure of a session request. The application must read the Session Request Success bit in the OTG Control and Status register (GOTGCTL.SesReqScs) to check for success or failure.	Host and Device	1'b0
7:3	-	-	Reserved	-	6'h0
2	R_SS_WC	SesEndDet	Session End Detected The core sets this bit when the utmiotg_bvalid signal is denied.	Host and Device	1'b0
1:0	-	-	Reserved	-	2'h0

GAHBCFG: Core AHB Configuration Register (offset: 0x008)

Bits	Type	Name	Description	Mode	Initial value
31:9	-	-	Reserved	-	22'h0
8	R/W	PTxFEmpLvl	Periodic Tx FIFO Empty Level Indicates when the Periodic Tx FIFO Empty Interrupt bit in the Core Interrupt register (GINTSTS.PTxFEmp) is triggered. This bit is used only in Slave mode. <ul style="list-style-type: none"> 1'b0: GINTSTS.PTxFEmp interrupt indicates that the Periodic Tx FIFO is half empty 1'b1: GINTSTS.PTxFEmp interrupt indicates that the Periodic Tx FIFO is completely empty 	Host only	1'b0

7	R/W	NPTxFEmpLvl	<p>Non-Periodic Tx FIFO Empty Level</p> <p>This bit is used only in Slave mode.</p> <p>In host mode and with Shared FIFO with device mode, this bit indicates when the Non-Periodic Tx FIFO Empty Interrupt bit in the Core Interrupt register (GINTSTS.NPTxFEmp) is triggered.</p> <p>With dedicated FIFO in device mode, this bit indicates when IN endpoint Transmit FIFO empty interrupt (DIEPINTn.TxFEmp) is triggered.</p> <p>Host mode and with Shared FIFO with device mode:</p> <ul style="list-style-type: none"> • 1'b0: GINTSTS.NPTxFEmp interrupt indicates that the Non-Periodic Tx FIFO is half empty • 1'b1: GINTSTS.NPTxFEmp interrupt indicates that the Non-Periodic Tx FIFO is completely empty <p>Dedicated FIFO in device mode:</p> <ul style="list-style-type: none"> • 1'b0: DIEPINTn.TxFEmp interrupt indicates that the IN Endpoint Tx FIFO is half empty • 1'b1: DIEPINTn.TxFEmp interrupt indicates that the IN Endpoint Tx FIFO is completely empty 	Host and Device	1'b0
6	-	-	Reserved	-	1'b0
5	R/W	DMAEn	<p>DMA Enable</p> <ul style="list-style-type: none"> • 1'b0: Core operates in Slave mode • 1'b1: Core operates in a DMA mode <p>This bit is always 0 when Slave-Only mode has been selected for the Architecture in coreConsultant (parameter OTG_ARCHITECTURE = 0).</p>	Host and Device	1'b0
4:1	R/W	HBstLen	<p>Burst Length/Type</p> <p>This field is used in both External and Internal DMA modes. In External DMA mode, these bits appear on dma_burst [3:0] ports, which can be used by an external wrapper to interface the External DMA Controller interface to Synopsys DW_ahb_dmac or ARM PrimeCell.</p> <p>External DMA Mode—defines the DMA burst length in terms of 32-bit words:</p> <ul style="list-style-type: none"> • 4'b0000: 1 word • 4'b0001: 4 words • 4'b0010: 8 words • 4'b0011: 16 words • 4'b0100: 32 words • 4'b0101: 64 words • 4'b0110: 128 words • 4'b0111: 256 words • Others: Reserved <p>Internal DMA Mode—AHB Master burst type:</p> <ul style="list-style-type: none"> • 4'b0000 Single • 4'b0001 INCR • 4'b0011 INCR4 • 4'b0101 INCR8 • 4'b0111 INCR16 • Others: Reserved 	Host and Device	4'b0

0	R/W	GblIntrMsk	<p>Global Interrupt Mask</p> <p>The application uses this bit to mask or unmask the interrupt line assertion to itself. Irrespective of this bit's setting, the interrupt status registers are updated by the core.</p> <ul style="list-style-type: none"> •1'b0: Mask the interrupt assertion to the application. •1'b1: Unmask the interrupt assertion to the application. 	Host and Device	1'b0
---	-----	------------	--	-----------------	------

GUSBCFG: Core USB Configuration Register (offset: 0x00C)

Bits	Type	Name	Description	Mode	Initial value
31	R/W	Corrupt Tx packet	<p>Corrupt Tx packet</p> <p>This bit is for debug purposes only. Never set this bit to 1.</p>	Host and Device	1'b0
30	R/W	ForceDevMode	<p>Force Device Mode</p> <p>Writing a 1 to this bit will force the core to device mode irrespective of utmiotg_iddig input pin.</p> <ul style="list-style-type: none"> • 1'b0: Normal Mode. • 1'b1: Force Device Mode. <p>After setting the force bit, the application must wait at least 25 ms before the change to take effect. When the simulation is in scale down mode, waiting for 500 us is sufficient.</p>	Host and Device	1'b0
29	R/W	ForceHstMode	<p>Writing a 1 to this bit will force the core to host mode irrespective of utmiotg_iddig input pin.</p> <ul style="list-style-type: none"> • 1'b0: Normal Mode. • 1'b1: Force Host Mode. <p>After setting the force bit, the application must wait at least 25 ms before the change to take effect. When the simulation is in scale down mode, waiting for 500 us is sufficient.</p>	Host and Device	1'b0
28:23	-	-	Reserved	-	6'h0
22	R/W	TermSelDLPUlse	<p>ULPI External VBUS Indicator</p> <p>This bit indicates to the ULPI PHY to use an external VBUS over-current indicator.</p> <ul style="list-style-type: none"> • 1'b0: PHY uses internal VBUS valid comparator. • 1'b1: PHY uses external VBUS valid comparator. (Valid only when RTL parameter OTG_HSPHY_INTERFACE = 2 or 3) 	Device Only	1'b0
21	R/W	ULPIExtVbusIndicator	<p>ULPI External VBUS Indicator</p> <p>This bit indicates to the ULPI PHY to use an external VBUS over-current indicator.</p> <ul style="list-style-type: none"> • 1'b0: PHY uses internal VBUS valid comparator. • 1'b1: PHY uses external VBUS valid comparator. (Valid only when RTL parameter OTG_HSPHY_INTERFACE = 2 or 3) 	Host Only	1'b0
20	R/W	ULPIExtVbusDrv	<p>ULPI External VBUS Drive</p> <p>This bit selects between internal or external supply to drive 5V on VBUS, in ULPI PHY.</p> <ul style="list-style-type: none"> • 1'b0: PHY drives VBUS using internal charge pump (default). • 1'b1: PHY drives VBUS using external supply. (Valid only when RTL parameter OTG_HSPHY_INTERFACE = 2 or 3) 	Host Only	1'b0

19	R/W	ULPIClkSusM	<p>ULPI Clock SuspendM</p> <p>This bit sets the ClockSuspendM bit in the Interface Control register on the ULPI PHY. This bit applies only in serial or car kit modes.</p> <ul style="list-style-type: none"> 1'b0: PHY powers down internal clock during suspend. 1'b1: PHY does not power down internal clock. <p>(Valid only when RTL parameter OTG_HSPHY_INTERFACE = 2 or 3)</p>	Host and Device	1'b0
18	R/W	ULPIAutoRes	<p>ULPI Auto Resume</p> <p>This bit sets the AutoResume bit in the Interface Control register on the ULPI PHY.</p> <ul style="list-style-type: none"> 1'b0: PHY does not use AutoResume feature. 1'b1: PHY uses AutoResume feature. <p>(Valid only when RTL parameter OTG_HSPHY_INTERFACE = 2 or 3)</p>	Host and Device	1'b0
17	R/W	ULPIFsLs	<p>ULPI FS/LS Selec</p> <p>The application uses this bit to select the FS/LS serial interface for the ULPI PHY. This bit is valid only when the FS serial transceiver is selected on the ULPI PHY.</p> <ul style="list-style-type: none"> 1'b0: ULPI interface 1'b1: ULPI FS/LS serial interface <p>(Valid only when RTL parameters OTG_HSPHY_INTERFACE = 2 or 3 and OTG_FSPHY_INTERFACE = 1, 2, or 3)</p>	Host and Device	1'b0
16	RO/R_W	OtgI2CSel	<p>UTMIFS or I C Interface Selec</p> <p>The application uses this bit to select the I2C interface.</p> <ul style="list-style-type: none"> 1'b0: UTMI USB 1.1 Full-Speed interface for OTG signals 1'b1: I2C interface for OTG signals <p>This bit is writable only if I2C and UTMIFS were specified for Enable I2C Interface? in coreConsultant (parameter OTG_I2C_INTERFACE = 2). Otherwise, reads return 0.</p>	Host and Device	1'b0
15	R/W	PhyLPwrClkSel	<p>PHY Low-Power Clock Select</p> <p>Selects either 480-MHz or 48-MHz (low-power) PHY mode. In FS and LS modes, the PHY can usually operate on a 48-MHz clock to save power.</p> <ul style="list-style-type: none"> 1'b0: 480-MHz Internal PLL clock 1'b1: 48-MHz External Clock <p>In 480 MHz mode, the UTMI interface operates at either 60 or 30-MHz, depending upon whether 8- or 16-bit data width is selected. In 48-MHz mode, the UTMI interface operates at 48 MHz in FS mode and at either 48 or 6 MHz in LS mode (depending on the PHY vendor).</p> <p>This bit drives the utmi_fsls_low_power core output signal, and is valid only for UTMI+ PHYs.</p>	Host and Device	1'b0
14	-	-	Reserved	-	1'b0

13:10	R/W	USBTrdTim	<p>USB Turnaround Time Sets the turnaround time in PHY clocks. Specifies the response time for a MAC request to the Packet FIFO Controller (PFC) to fetch data from the DFIFO (SPRAM).</p> <p>This must be programmed to</p> <ul style="list-style-type: none"> • 4'h5: When the MAC interface is 16-bit UTMI+. • 4'h9: When the MAC interface is 8-bit UTMI+. <p>Note: The values above are calculated for the minimum AHB frequency of 30 MHz. USB turnaround time is critical for certification where long cables and 5-Hubs are used, so if you need the AHB to run at less than 30 MHz, and if USB turnaround time is not critical, these bits can be programmed to a larger value. See "Choosing the Value of GUSBCFG_USBTrdTim" on page 411.</p>	Device only	4'h5
9	RO/R_W	HNPCap	<p>HNP-Capable The application uses this bit to control the DWC_otg core's HNP capabilities.</p> <ul style="list-style-type: none"> • 1'b0: HNP capability is not enabled. • 1'b1: HNP capability is enabled. <p>This bit is writable only if an HNP mode was specified for Mode of Operation in coreConsultant (parameter OTG_MODE). Otherwise, reads return 0.</p>	Host and Device	1'b0
8	RO/R_W	SRPCap	<p>SRP-Capable The application uses this bit to control the DWC_otg core SRP capabilities. If the core operates as a non-SRP-capable B-device, it cannot request the connected A-device (host) to activate VBUS and start a session.</p> <ul style="list-style-type: none"> • 1'b0: SRP capability is not enabled. • 1'b1: SRP capability is enabled. <p>This bit is writable only if an SRP mode was specified for Mode of Operation in coreConsultant (parameter OTG_MODE). Otherwise, reads return 0.</p>	Host and Device	1'b0
7	R/W	DDRSel	<p>ULPI DDR Select The application uses this bit to select a Single Data Rate (SDR) or Double Data Rate (DDR) or ULPI interface.</p> <ul style="list-style-type: none"> • 1'b0: Single Data Rate ULPI Interface, with 8-bit-wide data bus • 1'b1: Double Data Rate ULPI Interface, with 4-bit-wide data bus 	Host and Device	1'b0

6	WO/R _W	PHYSel	<p>USB 2.0 High-Speed PHY or USB 1.1 Full-Speed Serial Transceiver Select</p> <p>The application uses this bit to select either a high-speed UTMI+ or ULPI PHY, or a full-speed transceiver.</p> <ul style="list-style-type: none"> • 1'b0: USB 2.0 high-speed UTMI+ or ULPI PHY • 1'b1: USB 1.1 full-speed serial transceiver <p>If a USB 1.1 Full-Speed Serial Transceiver interface was not selected in coreConsultant (parameter OTG_FSPHY_INTERFACE = 0), this bit is always 0, with Write Only access.</p> <p>If a high-speed PHY interface was not selected in coreConsultant (parameter OTG_HSPHY_INTERFACE = 0), this bit is always 1, with Write Only access.</p> <p>If both interface types were selected in coreConsultant (parameters have non-zero values), the application uses this bit to select which interface is active, and access is Read and Write.</p>	Host and Device	1'b0
5	WO/R _W	FSIntf	<p>Full-Speed Serial Interface Select</p> <p>The application uses this bit to select either a unidirectional or bidirectional USB 1.1 full-speed serial transceiver interface.</p> <ul style="list-style-type: none"> • 1'b0: 6-pin unidirectional full-speed serial interface • 1'b1: 3-pin bidirectional full-speed serial interface <p>If a USB 1.1 Full-Speed Serial Transceiver interface was not selected in coreConsultant (parameter OTG_FSPHY_INTERFACE = 0), this bit is always 0, with Write Only access.</p> <p>If a USB 1.1 FS interface was selected in coreConsultant (parameter OTG_FSPHY_INTERFACE! = 0), then the application can set this bit to select between the 3- and 6-pin interfaces, and access is Read and Write.</p>	Host and Device	1'b0
4	RO/R _W	ULPI_UTMI_Sel	<p>ULPI or UTMI+ Select</p> <p>The application uses this bit to select either a UTMI+ interface or ULPI Interface.</p> <ul style="list-style-type: none"> • 1'b0: UTMI+ Interface • 1'b1: ULPI Interface <p>This bit is writable only if UTMI+ and ULPI was specified for High-Speed PHY Interface(s) in coreConsultant configuration (parameter OTG_HSPHY_INTERFACE = 3). Otherwise, reads return either 0 or 1, depending on the interface selected using the OTG_HSPHY_INTERFACE parameter.</p>	Host and Device	1'b0

3	RO/R _W	PHYif	<p>PHY Interface</p> <p>The application uses this bit to configure the core to support a UTMI+ PHY with an 8- or 16-bit interface. When a ULPI PHY is chosen, this must be set to 8-bit mode.</p> <ul style="list-style-type: none"> • 1'b0: 8 bits • 1'b1: 16 bits <p>This bit is writable only if UTMI+ and ULPI were selected in coreConsultant configuration (parameter OTG_HSPHY_DWIDTH = 3). Otherwise, this bit returns the value for the power-on interface selected during configuration.</p>	Host and Device	1'b0
2:0	R/W	TOutCal	<p>HS/FS Timeout Calibration</p> <p>The number of PHY clocks that the application programs in this field is added to the high-speed/full-speed interpacket timeout duration in the core to account for any additional delays introduced by the PHY. This can be required, because the delay introduced by the PHY in generating the linestate condition can vary from one PHY to another.</p> <p>The USB standard timeout value for high-speed operation is 736 to 816 (inclusive) bit times. The USB standard timeout value for full-speed operation is 16 to 18 (inclusive) bit times.</p> <p>The application must program this field based on the speed of enumeration. The number of bit times added per PHY clock are:</p> <p>High-speed operation:</p> <ul style="list-style-type: none"> • One 30-MHz PHY clock = 16 bit times • One 60-MHz PHY clock = 8 bit times <p>Full-speed operation:</p> <ul style="list-style-type: none"> • One 30-MHz PHY clock = 0.4 bit times • One 60-MHz PHY clock = 0.2 bit times • One 48-MHz PHY clock = 0.25 bit times 	Host and Device	3'h0

GRSTCTL: Core Reset Register (offset: 0x010)

Bits	Type	Name	Description	Mode	Initial value
31	R/O	AHBIdle	AHB Master Idle Indicates that the AHB Master State Machine is in the IDLE condition.	Host and Device	1'b1
30	R/O	DMAReq	DMA Request Signal Indicates that the DMA request is in progress. Used for debug.	Host and Device	1'b0
29:11	-	-	Reserved	-	19'h0

10:6	R/W	TxFNum	<p>TxFIFO Number This is the FIFO number that must be flushed using TxFIFO Flush bit. This field must not be changed until core clears the TxFIFO Flush bit.</p> <ul style="list-style-type: none"> • 5'h0: <ul style="list-style-type: none"> - Non-periodic TxFIFO flush in Host mode - Non-periodic TxFIFO flush in device mode when in shared FIFO operation - Tx FIFO 0 flush in device mode when in dedicated FIFO mode • 5'h1: <ul style="list-style-type: none"> - Periodic TxFIFO flush in Host mode - Periodic TxFIFO 1 flush in Device mode when in shared FIFO operation - TxFIFO 1 flush in device mode when in dedicated FIFO mode • 5'h2: <ul style="list-style-type: none"> - Periodic TxFIFO 2 flush in Device mode when in shared FIFO operation - TxFIFO 2 flush in device mode when in dedicated FIFO mode ... • 5'hF: <ul style="list-style-type: none"> - Periodic TxFIFO 15 flush in Device mode when in shared FIFO operation - TxFIFO 15 flush in device mode when in dedicated FIFO mode • 5'h10: Flush all the transmit FIFOs in device or host mode. 	Host and Device	5'h0
5	R_WS _SC	TxFFlsh	<p>TxFIFO Flush This bit selectively flushes a single or all transmit FIFOs, but cannot do so if the core is in the midst of a transaction. The application must write this bit only after checking that the core is neither writing to the TxFIFO nor reading from the TxFIFO. Verify using these registers:</p> <ul style="list-style-type: none"> • Read—NAK Effective Interrupt ensures the core is not reading from the FIFO • Write—GRSTCTL.AHBIdle ensures the core is not writing anything to the FIFO. <p>Flushing is normally recommended when FIFOs are reconfigured or when switching between Shared FIFO and Dedicated Transmit FIFO operation. FIFO flushing is also recommended during device endpoint disable. The application must wait until the core clears this bit before performing any operations. This bit takes eight clocks to clear, using the slower clock of phy_clk or hclk.</p>	Host and Device	1'b0

4	R_WS_SC	RxFFlsh	<p>RxFIFO Flush</p> <p>The application can flush the entire RxFIFO using this bit, but must first ensure that the core is not in the middle of a transaction.</p> <p>The application must only write to this bit after checking that the core is neither reading from the RxFIFO nor writing to the RxFIFO.</p> <p>The application must wait until the bit is cleared before performing any other operations. This bit requires 8 clocks (slowest of PHY or AHB clock) to clear.</p>	Host and Device	1'b0
3	R_WS_SC	INTknQFlsh	<p>IN Token Sequence Learning Queue Flush</p> <p>This bit is valid only if OTG_EN_DED_TX_FIFO = 0. The application writes this bit to flush the IN Token Sequence Learning Queue.</p>	Device only	1'b0
2	R_WS_SC	FrmCntrRst	<p>Host Frame Counter Reset</p> <p>The application writes this bit to reset the (micro) frame number counter inside the core. When the (micro)frame counter is reset, the subsequent SOF sent out by the core has a (micro) frame number of 0.</p>	Host only	1'b0
1	R_WS_SC	HSftRst	<p>HClk Soft Reset</p> <p>The application uses this bit to flush the control logic in the AHB Clock domain. Only AHB Clock Domain pipelines are reset.</p> <ul style="list-style-type: none"> FIFOs are not flushed with this bit. All state machines in the AHB clock domain are reset to the Idle state after terminating the transactions on the AHB, following the protocol. CSR control bits used by the AHB clock domain state machines are cleared. To clear this interrupt, status mask bits that control the interrupt status and are generated by the AHB clock domain state machine are cleared. Because interrupt status bits are not cleared, the application can get the status of any core events that occurred after it set this bit. <p>This is a self-clearing bit that the core clears after all necessary logic is reset in the core. This can take several clocks, depending on the core's current state.</p>	Host and Device	1'b0

0	R_WS_SC	CSftRst	<p>Core Soft Reset Resets the hclk and phy_clock domains as follows:</p> <ul style="list-style-type: none"> • Clears the interrupts and all the CSR registers except the following register bits: <ul style="list-style-type: none"> - PCGCCTL.RstPdownModule - PCGCCTL.GateHclk - PCGCCTL.PwrClmp - PCGCCTL.StopPPhyLPwrClkSelclk - GUSBCFG.PhyLPwrClkSel - GUSBCFG.DDRSel - GUSBCFG.PHYSel -GUSBCFG.FSIntf - GUSBCFG.ULPI_UTMI_Sel - GUSBCFG.PHYIf - HCFG.FSLSPclkSel - DCFG.DevSpd -GGPIO • All module state machines (except the AHB Slave Unit) are reset to the IDLE state, and all the transmit FIFOs and the receive FIFO are flushed. • Any transactions on the AHB Master are terminated as soon as possible, after gracefully completing the last data phase of an AHB transfer. Any transactions on the USB are terminated immediately. <p>The application can write to this bit any time it wants to reset the core. This is a self-clearing bit and core clears this bit after all the necessary logic is reset in the core, which can take several clocks, depending on the current state of the core. Once this bit is cleared software must wait at least 3 PHY clocks before doing any access to the PHY domain (synchronization delay). Software must also must check that bit 31 of this register is 1 (AHB Master is IDLE) before starting any operation. Typically software reset is used during software development and also when you dynamically change the PHY selection bits in the USB configuration registers listed above. When you change the PHY, the corresponding clock for the PHY is selected and used in the PHY domain. Once a new clock is selected, the PHY domain has to be reset for proper operation.</p>	Host and Device	1'b0
---	---------	---------	---	-----------------	------

GINTSTS: Core Interrupt Register (offset: 0x014)

Bits	Type	Name	Description	Mode	Initial value
31	R_SS_WC	WkUpInt	Resume/Remote Wakeup Detected Interrupt In Device mode, this interrupt is asserted when a resume is detected on the USB. In Host mode, this interrupt is asserted when a remote wakeup is detected on the USB. For more information on how to use this interrupt, see "Partial Power-Down and Clock Gating Programming Model" on page 417.	Host and Device	1'b0
30	R_SS_WC	SessReqInt	Session Request/New Session Detected Interrupt In Host mode, this interrupt is asserted when a session request is detected from the device. In Device mode, this interrupt is asserted when the	Host and Device	1'b0

			utmiotg_bvalid signal goes high. For more information on how to use this interrupt, see "Partial Power-Down and Clock Gating Programming Model" on page 417.		
29	R_SS_WC	DisconnInt	Disconnect Detected Interrupt Asserted when a device disconnect is detected.	Host Only	1'b0
28	R_SS_WC	ConIDStsChng	Connector ID Status Change The core sets this bit when there is a change in connector ID status.	Host and Device	1'b0
27	-	-	Reserved	-	1'b0
26	RO	PTxFEmp	Periodic TxFIFO Empty Asserted when the Periodic Transmit FIFO is either half or completely empty and there is space for at least one entry to be written in the Periodic Request Queue. The half or completely empty status is determined by the Periodic TxFIFO Empty Level bit in the Core AHB Configuration register (GAHB_CFG.PTxFEmpLv).	Host only	1'b1
25	RO	HChInt	Host Channels Interrupt The core sets this bit to indicate that an interrupt is pending on one of the channels of the core (in Host mode). The application must read the Host All Channels Interrupt (HAINT) register to determine the exact number of the channel on which the interrupt occurred, and then read the corresponding Host Channel-n Interrupt (HCINTn) register to determine the exact cause of the interrupt. The application must clear the appropriate status bit in the HCINTn register to clear this bit.	Host only	1'b0
24	RO	PrtInt	Host Port Interrupt The core sets this bit to indicate a change in port status of one of the DWC_otg core ports in Host mode. The application must read the Host Port Control and Status (HPRT) register to determine the exact event that caused this interrupt. The application must clear the appropriate status bit in the Host Port Control and Status register to clear this bit.	Host only	1'b0
23	-	-	Reserved	-	1'b0
22	R_SS_WC	FetSusp	Data Fetch Suspended This interrupt is valid only in DMA mode. This interrupt indicates that the core has stopped fetching data for IN endpoints due to the unavailability of TxFIFO space or Request Queue space. This interrupt is used by the application for an endpoint mismatch algorithm. For example, after detecting an endpoint mismatch, the application: <ul style="list-style-type: none"> • Sets a global non-periodic IN NAK handshake • Disables In endpoints • Flushes the FIFO • Determines the token sequence from the IN Token Sequence 	Device only	1'b0

			<p>Learning Queue</p> <ul style="list-style-type: none"> • Re-enables the endpoints • Clears the global non-periodic IN NAK handshake <p>If the global non-periodic IN NAK is cleared, the core has not yet fetched data for the IN endpoint, and the IN token is received: the core generates an “IN token received when FIFO empty” interrupt. The OTG then sends the host a NAK response. To avoid this scenario, the application can check the GINTSTS. FetSusp interrupt, which ensures that the FIFO is full before clearing a global NAK handshake. Alternatively, the application can mask the “IN token received when FIFO empty” interrupt when clearing a global IN NAK handshake.</p>		
21	R_SS_WC	incomplP	<p>Incomplete Periodic Transfer In Host mode, the core sets this interrupt bit when there are incomplete periodic transactions still pending which are scheduled for the current microframe.</p> <p>Incomplete Isochronous OUT Transfer (incompISOOUT) The Device mode, the core sets this interrupt to indicate that there is at least one isochronous OUT endpoint on which the transfer is not completed in the current microframe. This interrupt is asserted along with the End of Periodic Frame Interrupt (EOPF) bit in this register.</p>	Host only	1'b0
20	R_SS_WC	incompISOIN	<p>Incomplete Isochronous IN Transfer The core sets this interrupt to indicate that there is at least one isochronous IN endpoint on which the transfer is not completed in the current microframe. This interrupt is asserted along with the End of Periodic Frame Interrupt (EOPF) bit in this register</p>	Device only	1'b0
19	RO	OEPInt	<p>OUT Endpoints Interrupt The core sets this bit to indicate that an interrupt is pending on one of the OUT endpoints of the core (in Device mode). The application must read the Device All Endpoints Interrupt (DAINT) register to determine the exact number of the OUT endpoint on which the interrupt occurred, and then read the corresponding Device OUT Endpoint-n Interrupt (DOEPINTn) register to determine the exact cause of the interrupt. The application must clear the appropriate status bit in the corresponding DOEPINTn register to clear this bit.</p>	Device only	1'b0
18	RO	IEPInt	<p>IN Endpoints Interrupt The core sets this bit to indicate that an interrupt is pending on one of the IN endpoints of the core (in Device mode). The application must read the Device All Endpoints Interrupt (DAINT) register to determine the exact number of the IN endpoint on which the interrupt</p>	Device only	1'b0

			occurred, and then read the corresponding Device IN Endpoint-n Interrupt (DIEPINTn) register to determine the exact cause of the interrupt. The application must clear the appropriate status bit in the corresponding DIEPINTn register to clear this bit.		
17	R_SS_WC	EPMis	Endpoint Mismatch Interrupt Note: This interrupt is valid only in shared FIFO operation. Indicates that an IN token has been received for a non-periodic endpoint, but the data for another endpoint is present in the top of the Non-periodic Transmit FIFO and the IN endpoint mismatch count programmed by the application has expired.	Device only	1'b0
16	-	-	Reserved	-	1'b0
15	R_SS_WC	EOPF	End of Periodic Frame Interrupt Indicates that the period specified in the Periodic Frame Interval field of the Device Configuration register (DCFG.PerFrInt) has been reached in the current microframe.	Device only	1'b0
14	R_SS_WC	ISOOutDrop	Isochronous OUT Packet Dropped Interrupt The core sets this bit when it fails to write an isochronous OUT packet into the Rx FIFO because the Rx FIFO doesn't have enough space to accommodate a maximum packet size packet for the isochronous OUT endpoint.	Device only	1'b0
13	R_SS_WC	EnumDone	Enumeration Done The core sets this bit to indicate that speed enumeration is complete. The application must read the Device Status (DSTS) register to obtain the enumerated speed.	Device only	1'b0
12	R_SS_WC	USBRst	USB Reset The core sets this bit to indicate that a reset is detected on the USB.	Device only	1'b0
11	R_SS_WC	USBSusp	USB Suspend The core sets this bit to indicate that a suspend was detected on the USB. The core enters the Suspended state when there is no activity on the phy_line_state_i signal for an extended period of time.	Device only	1'b0
10	R_SS_WC	ErlySusp	Early Suspend The core sets this bit to indicate that an Idle state has been detected on the USB for 3 ms.	Device only	1'b0
9	R_SS_WC	I2CINT	I2C Interrupt The core sets this interrupt when I2C access is completed on the I2C interface. This field is used only if the I2C interface was enabled in coreConsultant (parameter OTG_I2C_INTERFACE = 1). Otherwise, reads return 0.	Host and Device	1'b0

8	R_SS_WC	ULPICKINT	<p>ULPI Carkit Interrupt This field is used only if the Carkit interface was enabled in coreConsultant (parameter OTG_ULPI_CARKIT = 1). Otherwise, reads return 0.</p> <p>The core sets this interrupt when a ULPI Carkit interrupt is received. The core's PHY sets ULPI Carkit interrupt in UART o Audio mode.</p> <p>I2C Carkit Interrupt (I2CCKINT) This field is used only if the I2C interface was enabled in coreConsultant (parameter OTG_I2C_INTERFACE = 1). Otherwise, reads return 0.</p> <p>The core sets this interrupt when a Carkit interrupt is received The core's PHY sets the I2C Carkit interrupt in Audio mode.</p>	Host and Device	1'b0
7	RO	GOUTNakEff	<p>Global OUT NAK Effective Indicates that the Set Global OUT NAK bit in the Device Control register (DCTL.SGOUTNak), set by the application, has taken effect in the core. This bit can be cleared by writing the Clear Global OUT NAK bit in the Device Control register (DCTL.CGOUTNak).</p>	Device only	1'b0
6	RO	GINNakEff	<p>Global IN Non-periodic NAK Effective Indicates that the Set Global Non-periodic IN NAK bit in the Device Control register (DCTL.SGNPinNak), set by the application, has taken effect in the core. That is, the core has sampled the Global IN NAK bit set by the application. This bit can be cleared by clearing the Clear Global Non-periodic IN NAK bit in the Device Control register (DCTL.CGNPinNak). This interrupt does not necessarily mean that a NAK handshake is sent out on the USB. The STALL bit takes precedence over the NAK bit.</p>	Device only	1'b0
5	RO	NPTxFEmp	<p>Non-periodic Tx FIFO Empty This interrupt is valid only when OTG_EN_DED_TX_FIFO = 0. This interrupt is asserted when the Non-periodic Tx FIFO is either half or completely empty, and there is space for at least one entry to be written to the Non-periodic Transmit Request Queue. The half or completely empty status is determined by the Non-periodic Tx FIFO Empty Level bit in the Core AHB Configuration register (GAHBCFG.NPTxFEmpLvl).</p>	Host and Device	1'b1
4	RO	RxFLvl	<p>RxFIFO Non-Empty Indicates that there is at least one packet pending to be read from the RxFIFO.</p>	Host and Device	1'b0
3	R_SS_WC	Sof	<p>Start of (micro)Frame In Host mode, the core sets this bit to indicate that an SOF (FS), micro-SOF (HS), or Keep-Alive (LS) is transmitted on the USB. The application must write a 1 to this bit to clear the interrupt. In Device mode, in the core sets this bit to indicate</p>	Host and Device	1'b0

			that an SOF token has been received on the USB. The application can read the Device Status register to get the current (micro)frame number. This interrupt is seen only when the core is operating at either HS or FS.		
2	RO	OTGInt	OTG Interrupt The core sets this bit to indicate an OTG protocol event. The application must read the OTG Interrupt Status (GOTGINT) register to determine the exact event that caused this interrupt. The application must clear the appropriate status bit in the GOTGINT register to clear this bit.	Host and Device	1'b0
1	R_SS_WC	ModeMis	Mode Mismatch Interrupt The core sets this bit when the application is trying to access: <ul style="list-style-type: none"> • A Host mode register, when the core is operating in Device mode • A Device mode register, when the core is operating in Host Mode The register access is completed on the AHB with an OKAY response, but is ignored by the core internally and doesn't affect the operation of the core. 	Host and Device	1'b0
0	RO	CurMod	Current Mode of Operation Indicates the current mode of operation. <ul style="list-style-type: none"> • 1'b0: Device mode • 1'b1: Host mode 	Host and Device	1'b0

GINTMSK: Core Interrupt Mask Register (offset: 0x018)

Bits	Type	Name	Description	Mode	Initial value
31	R/W	WkUpIntMsk	Resume/Remote Wakeup Detected Interrupt Mask	Host and Device	1'b0
30	R/W	SessReqIntMsk	Session Request/New Session Detected Interrupt Mask	Host and Device	1'b0
29	R/W	DisconnIntMsk	Disconnect Detected Interrupt Mask	Host and Device	1'b0
28	R/W	ConIDStsChngMsk	Connector ID Status Change Mask	Host and Device	1'b0
27	-	-	Reserved	-	1'b0
26	R/W	PTxFEmpMsk	Periodic Tx FIFO Empty Mask	Host only	1'b0
25	R/W	HChIntMsk	Host Channels Interrupt Mask	Host only	1'b0
24	R/W	PrtIntMsk	Host Port Interrupt Mask	Host only	1'b0
23	-	-	Reserved	-	1'b0
22	R/W	FetSuspMsk	Data Fetch Suspended Mask	Device only	1'b0
21	R/W	Incomplmsk	Incomplete Periodic Transfer Mask Incomplete Isochronous OUT Transfer Mask (incomplSOOUTMsk)	Host only Device only	1'b0
20	R/W	Incompisoinsk	Incomplete Isochronous IN Transfer Mask	Device only	1'b0
19	R/W	OEPIntMsk	OUT Endpoints Interrupt Mask	Device only	1'b0
18	R/W	IEPIntMsk	IN Endpoints Interrupt Mask	Device only	1'b0
17	R/W	EPMisMsk	Endpoint Mismatch Interrupt Mask	Device only	1'b0

16	-	-	Reserved		1'b0
15	R/W	EOPFMsk	End of Periodic Frame Interrupt Mask	Device only	1'b0
14	R/W	ISOOutDropMsk	Isochronous OUT Packet Dropped Interrupt Mask	Device only	1'b0
13	R/W	EnumDoneMsk	Enumeration Done Mask	Device only	1'b0
12	R/W	USBRstMsk	USB Reset Mask	Device only	1'b0
11	R/W	USBSuspMsk	USB Suspend Mask	Device only	1'b0
10	R/W	ErlySuspMsk	Early Suspend Mask	Device only	1'b0
9	R/W	I2CIntMsk	I2C Interrupt Mask	Host and Device	1'b0
8	R/W	ULPICKINTMsk I2CCKINTMsk	ULPI Carkit Interrupt Mask I2C Carkit Interrupt Mask	Host and Device	1'b0
7	R/W	GOUTNakEffMsk	Global OUT NAK Effective Mask	Device only	1'b0
6	R/W	GINNakEffMsk	Global Non-periodic IN NAK Effective Mask	Device only	1'b0
5	R/W	NPTxFEmpMsk	Non-periodic Tx FIFO Empty Mask	Host and Device	1'b0
4	R/W	RxFLvIMsk	Receive FIFO Non-Empty Mask	Host and Device	1'b0
3	R/W	SofMsk	Start of (micro)Frame Mask	Host and Device	1'b0
2	R/W	OTGIntMsk	OTG Interrupt Mask	Host and Device	1'b0
1	R/W	ModeMisMsk	Mode Mismatch Interrupt Mask	Host and Device	1'b0
0	-	-	Reserved	-	1'b0

GRXSTSR/GRXSTSP: Receive Status Debug Read/Status Read and Pop Registers (offset: 0x018)

Bits	Type	Name	Description	Mode	Initial value
31:20		Reserved	Resume/Remote Wakeup Detected Interrupt Mask	-	11'h0
20:17	RO	PktSts	Packet Status Indicates the status of the received packet <ul style="list-style-type: none"> • 4'b0010: IN data packet received • 4'b0011: IN transfer completed (triggers an interrupt) • 4'b0101: Data toggle error (triggers an interrupt) • 4'b0111: Channel halted (triggers an interrupt) • Others: Reserved 	-	4'b0
16:15	R/W	DPID	Data PID Indicates the Data PID of the received packet <ul style="list-style-type: none"> • 2'b00: DATA0 • 2'b10: DATA1 • 2'b01: DATA2 • 2'b11: MDATA 	-	2'b0
14:4	RO	BCnt	Byte Count Indicates the byte count of the received IN data packet.	-	11'h0
3:0	RO	ChNum	Channel Number Indicates the channel number to which the current	-	4'h0

			received packet belongs.		
--	--	--	--------------------------	--	--

GRXSTSR/GRXSTSP: Device Mode Receive Status Debug Read/Status Read and Pop Registers

Bits	Type	Name	Description	Mode	Initial value
31:25	-	-	Reserved	-	7'h0
24:21	RO	FN	Frame Number This is the least significant 4 bits of the (micro) frame number in which the packet is received on the USB. This field is supported only when isochronous OUT endpoints are supported.	-	4'h0
20:17	RO	PktSts	Packet Status Indicates the status of the received packet <ul style="list-style-type: none"> 4'b0001: Global OUT NAK (triggers an interrupt) 4'b0010: OUT data packet received 4'b0011: OUT transfer completed (triggers an interrupt) 4'b0100: SETUP transaction completed (triggers an interrupt) 4'b0110: SETUP data packet received Others: Reserved 	-	4'h0
16:15	RO	DPID	Data PID Indicates the Data PID of the received OUT data packet <ul style="list-style-type: none"> 2'b00: DATA0 2'b10: DATA1 2'b01: DATA2 2'b11: MDATA 	-	2'b0
16:4	RO	BCnt	Byte Count Indicates the byte count of the received data packet.	-	11'h0
3:0	RO	EPNum	Endpoint Number Indicates the endpoint number to which the current received packet belongs.	-	4'h0

GRXFSIZ: Receive FIFO Size Register (offset: 0x024)

Bits	Type	Name	Description	Mode	Initial value
31:16	-	-	Reserved	-	16'h0
15:0	RO	RxFDep	Rx FIFO Depth This value is in terms of 32-bit words. <ul style="list-style-type: none"> Minimum value is 16 Maximum value is 32,768 The power-on reset value of this register is specified as the Largest Rx Data FIFO Depth (parameter OTG_RX_DFIFO_DEPTH) during coreConsultant configuration. If Enable Dynamic FIFO Sizing? was deselected in coreConsultant (parameter OTG_DFIFO_DYNAMIC = 0), these flops are optimized, and reads return the power-on value. If Enable Dynamic FIFO Sizing? was selected in coreConsultant (parameter OTG_DFIFO_DYNAMIC = 1), you can write a new value in this field. You can write a new value in this field. Programmed values must not exceed the power-on value set in coreConsultant.	-	User-selected

GNPTXFSIZ: Non-Periodic Transmit FIFO Size Register (offset: 0x028)

Bits	Type	Name	Description	Mode	Initial value
31:16	RO/R _W	NPTxFDep	<p>Non-periodic TxFIFO Depth For host mode, this field is always valid. For Device mode, this field is valid only when OTG_EN_DED_TX_FIFO = 0 This value is in terms of 32-bit words. Minimum value is 16 Maximum value is 32,768 The power-on reset value of this register is specified as the Largest Non-periodic Tx Data FIFO Depth (parameter OTG_TX_NPERIO_DFIFO_DEPTH when OTG_EN_DED_TX_FIFO = 0. parameter OTG_TX_HNPERIO_DFIFO_DEPTH when OTG_EN_DED_TX_FIFO = 1) during coreConsultant configuration. If Enable Dynamic FIFO Sizing? was deselected in coreConsultant (parameter OTG_DFIFO_DYNAMIC = 0), these flops are optimized, and reads return the power-on value. If Enable Dynamic FIFO Sizing? was selected in coreConsultant (parameter OTG_DFIFO_DYNAMIC = 1), you can write a new value in this field. Programmed values must not exceed the power-on value set in coreConsultant. IN Endpoint TxFIFO 0 Depth (INEPTxF0Dep) This field is valid only for Device mode and when OTG_EN_DED_TX_FIFO = 1 This value is in terms of 32-bit words. Minimum value is 16 Maximum value is 32,768 The power-on reset value of this register is specified as the Largest IN Endpoint FIFO 0 Depth (parameter OTG_TX_DINEP_DFIFO_DEPTH_0) during coreConsultant configuration. If Enable Dynamic FIFO Sizing? was deselected in coreConsultant (parameter OTG_DFIFO_DYNAMIC = 0), these flops are optimized, and reads return the power-on value. If Enable Dynamic FIFO Sizing? was selected in coreConsultant (parameter OTG_DFIFO_DYNAMIC = 1), you can write a new value in this field. Programmed values must not exceed the power-on value set in coreConsultant.</p>	-	User-selected
15:0	RO/R _W	NPTxFStAddr	<p>Non-periodic Transmit RAM Start Address For host mode, this field is always valid. For Device mode, this field is valid only when OTG_EN_DED_TX_FIFO = 0 This field contains the memory start address for Non-periodic Transmit FIFO RAM. The power-on reset value of this register is specified as the Largest Rx Data FIFO Depth (parameter OTG_RX_DFIFO_DEPTH) during coreConsultant configuration. If Enable Dynamic FIFO Sizing? was deselected in coreConsultant (parameter OTG_DFIFO_DYNAMIC = 0), these flops are optimized, and reads return the</p>	-	User-selected

			<p>power-on value.</p> <p>If Enable Dynamic FIFO Sizing? was selected in coreConsultant (parameter OTG_DFIFO_DYNAMIC = 1), you can write a new value in this field. Programmed values must not exceed the power-on value set in coreConsultant.</p> <p>IN Endpoint FIFO0 Transmit RAM Start Address (INEPTxF0StAddr)</p> <p>This field is valid only for Device mode and when OTG_EN_DED_TX_FIFO = 1</p> <p>This field contains the memory start address for IN Endpoint Transmit FIFO# 0.</p> <p>The power-on reset value of this register is specified as the Largest Rx Data FIFO Depth (parameter OTG_RX_DFIFO_DEPTH) during coreConsultant configuration.</p> <p>OTG_RX_DFIFO_DEPTH</p> <p>If Enable Dynamic FIFO Sizing? was deselected in coreConsultant (parameter OTG_DFIFO_DYNAMIC = 0), these flops are optimized, and reads return the power-on value.</p> <p>If Enable Dynamic FIFO Sizing? was selected in coreConsultant (parameter OTG_DFIFO_DYNAMIC = 1), you can write a new value in this field. Programmed values must not exceed the power-on value set in coreConsultant.</p>		
--	--	--	---	--	--

GNPTXSTS: Non-Periodic Transmit FIFO/Queue Status Register (offset: 0x02C)

Bits	Type	Name	Description	Mode	Initial value
31	RO	-	Reserved	-	1'b0
30:24	RO	NPTxQTop	<p>Top of the Non-periodic Transmit Request Queue Entry in the Non-periodic Tx Request Queue that is currently being processed by the MAC.</p> <ul style="list-style-type: none"> • Bits [30:27]: Channel/endpoint number • Bits [26:25]: <ul style="list-style-type: none"> - 2'b00: IN/OUT token - 2'b01: Zero-length transmit packet (device IN/host OUT) - 2'b10: PING/CSPLIT token - 2'b11: Channel halt command • Bit [24]: Terminate (last entry for selected channel/endpoint) 	-	7'h0
23:16	RO	NPTxQSpCavail	<p>Non-periodic Transmit Request Queue Space Available</p> <p>Indicates the amount of free space available in the Non-periodic Transmit Request Queue. This queue holds both IN and OUT requests in Host mode. Device mode has only IN requests.</p> <ul style="list-style-type: none"> • 8'h0: Non-periodic Transmit Request Queue is full • 8'h1: 1 location available • 8'h2: 2 locations available • n: n locations available ($0 \leq n \leq 8$) • Others: Reserved 	-	User-selected
15:0	RO	NPTxFSpcAvail	<p>Non-periodic TxFIFO Space Avail</p> <p>Indicates the amount of free space available in the Non-periodic TxFIFO.</p>	-	User-selected

			<p>Values are in terms of 32-bit words.</p> <ul style="list-style-type: none"> • 16'h0: Non-periodic Tx FIFO is full • 16'h1: 1 word available • 16'h2: 2 words available • 16'hn: n words available (where $0 \leq n \leq 32,768$) • 16'h8000: 32,768 words available • Others: Reserved 		
--	--	--	--	--	--

GI2CCTL:I2C Access Register (offset: 0x030)

Bits	Type	Name	Description	Mode	Initial value
31	R_WS _SC	BsyDne	<p>I2C Busy/Done</p> <p>The application sets this bit to 1'b1 to start a request on the I2C interface. When the transfer is complete, the core deasserts this bit to 1'b0. As long as the bit is set, indicating that the I2C interface is busy, the application cannot start another request on the interface.</p>	-	1'b0
30	R/W	RW	<p>Read/Write Indicator</p> <p>Indicates whether a read or write register transfer must be performed on the interface. Read/write bursting is not supported for registers.</p> <ul style="list-style-type: none"> • 1'b1: Read • 1'b0: Write 	-	1'b0
29	-	-	Reserved	-	1'b0
28	R/W	I2CDatSe0	<p>I2C DatSe0 USB Mode</p> <p>Selects the address of the I2C Slave on the USB 1.1 full-speed serial transceiver that the core uses for OTG signaling.</p> <ul style="list-style-type: none"> • 2'b00: 7'h2C • 2'b01: 7'h2D • 2'b10: 7'h2E • 2'b11: 7'h2F 	-	1'b1
27:26	R/W	I2CDevAdr	<p>I2C Device Address</p> <p>Selects the address of the I C Slave on the USB 1.1 full-speed serial transceiver that the core uses for OTG signaling.</p> <ul style="list-style-type: none"> • 2'b00: 7'h2C • 2'b01: 7'h2D • 2'b10: 7'h2E • 2'b11: 7'h2F 	-	2'b0
25	R/W	I2CSuspCtl	<p>I2C Suspend Control</p> <p>Selects how Suspend is connected to a full-speed transceiver in I2C mode.</p> <p>1'b0: Use the dedicated utmi_suspend_n pin 1'b1: Use an I2C write to program the Suspend bit in the PHY register</p>	-	1'b0
24	RO	Ack	<p>I2C ACK</p> <p>Indicates whether an ACK response was received from the I2C Slave. This bit is valid when BsyDne is cleared by the core, after application has initiated an I2C access.</p> <ul style="list-style-type: none"> • 1'b0: NAK • 1'b1: ACK 	-	1'b1
23	R/W	I2CEn	<p>I2C Enable</p> <p>Enables the I2C Master to initiate I2C transactions on the I2C interface.</p>	-	1'b0

22:16	R/W	Addr	I2C Address This is the 7-bit I2C device address used by software to access any external I2C Slave, including the I2C Slave on a USB 1.1 OTG full-speed serial transceiver. Software can change this address to access different I2C Slaves.	-	7'h0
15:8	R/W	RegAddr	I2C Register Addr This field programs the address of the register to be read from or written to.	-	8'h00
7:0	R/W	RWData	I2C Read/Write Data After a register read operation, this field holds the read data for the application. During a write operation, the application can use this register to program the write data to be written to a register. During writes, this field holds the write data.	-	8'h00

GPVNDCTL: PHY Vendor Control Register (offset: 0x034)

Bits	Type	Name	Description	Mode	Initial value
31	R_WS_SC	DisUlpiDrvr	Disable ULPI Drivers This field is used only if the Carkit interface was enabled in coreConsultant (parameter OTG_ULPI_CARKIT = 1). Otherwise, reads return 0. The application sets this bit when it has finished processing the ULPI Carkit Interrupt (GINTSTS.ULPICKINT). When set, the DWC_otg core disables drivers for output signals and masks input signal for the ULPI interface. DWC_otg clears this bit before enabling the ULPI interface.	-	1'b0
30:28	-	-	Reserved	-	3'h0
27	R_SS_WC_SC	VStsDone	VStatus Done The core sets this bit when the vendor control access is done. This bit is cleared by the core when the application sets the New Register Request bit (bit 25).	-	1'b0
26	RO	VStsBsy	VStatus Busy The core sets this bit when the vendor control access is in progress and clears this bit when done.	-	1'b0
25	R_WS_SC	NewRegReq	New Register Request The application sets this bit for a new vendor control access.	-	1'b0
24:23	-	-	Reserved	-	2'h0
22	R/W	RegWr	Register Write Set this bit for register writes, and clear it for register reads.	-	1'b0
21:16	R/W	RegAddr	Register Address The 6-bit PHY register address for immediate PHY Register Set access. Set to 6'h2F for Extended PHY Register Set access.	-	6'h0
15:8	R/W	VCtrl	UTMI+ Vendor Control Register Address The 4-bit register address a vendor defined 4-bit parallel output bus. Bits 11:8 of this field are placed on utmi_vcontrol [3:0]. ULPI Extended Register Address (ExtRegAddr) The 6-bit PHY extended register address.	-	8'h0
7:0	R/W	RegData	Register Data Contains the write data for register write. Read data for register read, valid when VStatus Done is set.	-	8'h0

GGPIO: General Purpose Input/Output Register (offset: 0x038)

Bits	Type	Name	Description	Mode	Initial value
31:16	R/W	GPO	General Purpose Output This field is driven as an output from the core, gp_o [15:0]. The application can program this field to determine the corresponding value on the gp_o [15:0] output.	-	16'h0
15:0	RO	GPI	General Purpose Input This field's read value reflects the gp_i [15:0] core input value.	-	16'h0

GUID: User ID Register (offset: 0x03C)

Bits	Type	Name	Description	Mode	Initial value
31:0	R/W	UserID	User ID Application-programmable ID field.	-	User-selected

GSNPSID: Synopsys ID Register (offset: 0x040)

Bits	Type	Name	Description	Mode	Initial value
31:0	RO	SynopsysID	Synopsys ID Release number of the DWC_otg core being used, currently OT2.66a.	-	32'h4F54 <version>

GHWCFG1: Synopsys ID Register (offset: 0x044)

Bits	Type	Name	Description	Mode	Initial value
31:0	RO	epdir	Endpoint Direction Two bits per endpoint represent the direction. <ul style="list-style-type: none"> • 2'b00: BIDIR (IN and OUT) endpoint • 2'b01: IN endpoint • 2'b10: OUT endpoint • 2'b11: Reserved Bits [31:30]: Endpoint 15 direction Bits [29:28]: Endpoint 14 direction ... Bits [3:2]: Endpoint 1 direction Bits [1:0]: Endpoint 0 direction (always BIDIR) (coreConsultant parameter: OTG_EP_DIR_n).	-	User-selected

GHWCFG2: User HW Config2 Register (offset: 0x048)

Bits	Type	Name	Description	Mode	Initial value
31	-	-	Reserved	-	1'b0
30:26	RO	TknQDepth	Device Mode IN Token Sequence Learning Queue Depth Range: 0–30 (coreConsultant parameter: OTG_TOKEN_QUEUE_DEPTH)	-	User-selected
25:24	RO	PTxQDepth	Host Mode Periodic Request Queue Depth <ul style="list-style-type: none"> • 2'b00: 2 • 2'b01: 4 • 2'b10: 8 • Others: Reserved (coreConsultant parameter: OTG_PERIO_TX_QUEUE_DEPTH)	-	User-selected
23:22	RO	NPTxQDepth	Non-periodic Request Queue Depth <ul style="list-style-type: none"> • 2'b00: 2 • 2'b01: 4 • 2'b10: 8 • Others: Reserved (coreConsultant parameter: OTG_NPERIO_TX_QUEUE_DEPTH)	-	User-selected

21:20	-	-	Reserved	-	2'b0
19	RO	DynFifoSizing	Dynamic FIFO Sizing Enabled <ul style="list-style-type: none"> • 1'b0: No • 1'b1: Yes (coreConsultant parameter: OTG_DFIFO_DYNAMIC)	-	User-selected
18	RO	PerioSupport	Periodic OUT Channels Supported in Host Mode <ul style="list-style-type: none"> • 1'b0: No • 1'b1: Yes (coreConsultant parameter: OTG_EN_PERIO_HOST)	-	User-selected
17:14	RO	NumHstChnl	Number of Host Channels Indicates the number of host channels supported by the core in Host mode. The range of this field is 0–15: 0 specifies 1 channel, 15 specifies 16 channels. (coreConsultant parameter: OTG_NUM_HOST_CHAN)	-	User-selected
13:10	RO	NumDevEps	Number of Device Endpoints Indicates the number of device endpoints supported by the core in Device mode in addition to control endpoint 0. The range of this field is 1–15. (coreConsultant parameter: OTG_NUM_EPS)	-	User-selected
9:8	RO	FSPhyType	Full-Speed PHY Interface Type <ul style="list-style-type: none"> • 2'b00: Full-speed interface not supported • 2'b01: Dedicated full-speed interface • 2'b10: FS pins shared with UTMI+ pins • 2'b11: FS pins shared with ULPI pins (coreConsultant parameter: OTG_FSPHY_INTERFACE)	-	User-selected
7:6	RO	HSPhyType	High-Speed PHY Interface Type <ul style="list-style-type: none"> • 2'b00: High-Speed interface not supported • 2'b01: UTMI+ • 2'b10: ULPI • 2'b11: UTMI+ and ULPI (coreConsultant parameter: OTG_HSPHY_INTERFACE)	-	User-selected
5	RO	SingPnt	Point-to-Point <ul style="list-style-type: none"> • 1'b0: Multi-point application • 1'b1: Single-point application (coreConsultant parameter: OTG_SINGLE_POINT)	-	User-selected
4:3	RO	OtgArch	Architecture <ul style="list-style-type: none"> • 2'b00: Slave-Only • 2'b01: External DMA • 2'b10: Internal DMA • Others: Reserved (coreConsultant parameter: OTG_ARCHITECTURE)	-	User-selected
2:0	RO	OtgMode	Mode of Operation <ul style="list-style-type: none"> • 3'b000: HNP- and SRP-Capable OTG (Host & Device) • 3'b001: SRP-Capable OTG (Host & Device) • 3'b010: Non-HNP and Non-SRP Capable OTG (Host & Device) • 3'b011: SRP-Capable Device • 3'b100: Non-OTG Device • 3'b101: SRP-Capable Host • 3'b110: Non-OTG Host • Others: Reserved 	-	User-selected

			(coreConsultant parameter: OTG_MODE)		
--	--	--	--------------------------------------	--	--

GHWCFG3: User HW Config3 Register (offset: 0x04C)

Bits	Type	Name	Description	Mode	Initial value
31:16	RO	DfifoDepth	DFIFO Depth This value is in terms of 32-bit words. <ul style="list-style-type: none"> • Minimum value is 32 • Maximum value is 32,768 (coreConsultant parameter: OTG_DFIFO_DEPTH)	-	User-Selected
15:12	-	-	Reserved	-	4'b0
11	RO	RstType	Reset Style for Clocked always Blocks in RTL <ul style="list-style-type: none"> • 1'b0: Asynchronous reset is used in the core • 1'b1: Synchronous reset is used in the core (coreConsultant parameter: OTG_SYNC_RESET_TYPE)	-	User-selected
10	RO	OptFeature	Optional Features Removed Indicates whether the User ID register, GPIO interface ports, and SOF toggle and counter ports were removed for gate count optimization by enabling Remove Optional Features? during coreConsultant configuration. <ul style="list-style-type: none"> • 1'b0: No • 1'b1: Yes (coreConsultant parameter: OTG_RM_OPT_FEATURES)	-	User-selected
9	RO	VndctlSupt	Vendor Control Interface Support <ul style="list-style-type: none"> • 1'b0: Vendor Control Interface is not available on the core. • 1'b1: Vendor Control Interface is available. (coreConsultant parameter: OTG_VENDOR_CTL_INTERFACE)	-	User-selected
8	RO	I2CIntSel	I2C Selection <ul style="list-style-type: none"> • 1'b0: I2C Interface is not available on the core. • 1'b1: I2C Interface is available on the core. (coreConsultant parameter: OTG_I2C_INTERFACE)	-	User-selected
7	RO	OtgEn	OTG Function Enabled The application uses this bit to indicate the DWC_otg core's OTG capabilities. <ul style="list-style-type: none"> • 1'b0: Not OTG capable • 1'b1: OTG Capable (coreConsultant parameter: OTG_MODE)	-	1'b1
6:4	RO	PktSizeWidth	Width of Transfer Size Counters <ul style="list-style-type: none"> • 4'b0000: 11 bits • 4'b0001: 12 bits ... • 4'b1000: 19 bits • Others: Reserved (coreConsultant parameter: OTG_TRANS_COUNT_WIDTH)	-	User-selected
3:0	RO	XferSizeWidth	Width of Transfer Size Counters <ul style="list-style-type: none"> • 4'b0000: 11 bits • 4'b0001: 12 bits ... 	-	User-selected

			<ul style="list-style-type: none"> • 4'b1000: 19 bits • Others: Reserved (coreConsultant parameter: OTG_TRANS_COUNT_WIDTH)		
--	--	--	--	--	--

GHWCFG4: User HW Config4 Register (offset: 0x050)

Bits	Type	Name	Description	Mode	Initial value
31:30	-	-	Reserved	-	2'h0
29:26	RO	INEps	Number of Device Mode IN Endpoints Including Control Endpoints Range 0 -15 <ul style="list-style-type: none"> • 0: 1 IN Endpoint • 1: 2 IN Endpoints • • 15: 16 IN Endpoints 	-	User Specified
25	RO	DedFifoMode	Enable Dedicated Transmit FIFO for device IN Endpoints <ul style="list-style-type: none"> • 1'b0: Dedicated Transmit FIFO Operation not enabled. • 1'b1: Dedicated Transmit FIFO Operation enabled. (coreConsultant parameter: OTG_EN_DED_TX_FIFO)	-	User Selected
24	RO	SessEndFltr	"session_end" Filter Enabled <ul style="list-style-type: none"> • 1'b0: No filter • 1'b1: Filter (coreConsultant parameter: OTG_EN_SESSIONEND_FILTER)	-	User-Selected
23	RO	BValidFltr	"b_valid" Filter Enabled <ul style="list-style-type: none"> • 1'b0: No filter • 1'b1: Filter (coreConsultant parameter: OTG_EN_B_VALID_FILTER)	-	User-Selected
22	RO	AValidFltr	"a_valid" Filter Enabled <ul style="list-style-type: none"> • 1'b0: No filter • 1'b1: Filter (coreConsultant parameter: OTG_EN_A_VALID_FILTER)	-	User-Selected
21	RO	VBusValidFltr	"vbus_valid" Filter Enabled <ul style="list-style-type: none"> • 1'b0: No filter • 1'b1: Filter (coreConsultant parameter: OTG_EN_VBUSVALID_FILTER)	-	User-Selected
20	RO	IddgFltr	"iddig" Filter Enable <ul style="list-style-type: none"> • 1'b0: No filter • 1'b1: Filter (coreConsultant parameter: OTG_EN_IDDIG_FILTER)	-	User-Selected
19:16	RO	NumCtlEps	Number of Device Mode Control Endpoints in Addition to Endpoint 0 Range: 0-15 (coreConsultant parameter: OTG_NUM_CRL_EPS)	-	User-Selected
15:14	RO	PhyDataWidth	UTMI+ PHY/ULPI-to-Internal UTMI+ Wrapper Data Width	-	User-Selected

			When a ULPI PHY is used, an internal wrapper converts ULPI to UTMI+. <ul style="list-style-type: none"> • 2'b00: 8 bits • 2'b01: 16 bits • 2'b10: 8/16 bits, software selectable • Others: Reserved (coreConsultant parameter: OTG_HSPHY_DWIDTH)		
13:6	-	-	Reserved	-	8'h0
5	RO	AhbFreq	Minimum AHB Frequency Less Than 60 MHz <ul style="list-style-type: none"> • 1'b0: No • 1'b1: Yes (coreConsultant parameter: OTG_MIN_AHB_FREQ_LESSTHAN_60)	-	User-Selected
4	RO	EnablePwrOpt	Enable Power Optimization? <ul style="list-style-type: none"> • 1'b0: No • 1'b1: Yes (coreConsultant parameter: OTG_EN_PWROPT)	-	User-Selected
3:0	RO	NumDevPerioEps	Number of Device Mode Periodic IN Endpoints Range: 0–15 (coreConsultant parameter: OTG_NUM_PERIO_EPS)		User-Selected

HPTXFSIZ: Host Periodic Transmit FIFO Size Register (offset: 0x100)

Bits	Type	Name	Description	Mode	Initial value
31:16	RO / R_W	PTxFSize	Host Periodic Tx FIFO Depth This value is in terms of 32-bit words. <ul style="list-style-type: none"> • Minimum value is 16 • Maximum value is 32,768 The power-on reset value of this register is specified as the Largest Host Mode Periodic Tx Data FIFO Depth (parameter OTG_TX_HPERIO_DFIFO_DEPTH) during coreConsultant configuration. If Enable Dynamic FIFO Sizing? was deselected in coreConsultant (parameter TG_DFIFO_DYNAMIC = 0), these flops are optimized, and reads return the power-on value. If Enable Dynamic FIFO Sizing? was selected in coreConsultant (parameter TG_DFIFO_DYNAMIC = 1), you can write a new value in this field. Programmed values must not exceed the power-on value set in coreConsultant.	-	User-selected
15:0	RO / R_W	PTxFStAddr	Host Periodic Tx FIFO Start Address The power-on reset value of this register is the sum of the Largest Rx Data FIFO Depth and Largest Non-periodic Tx Data FIFO Depth specified during coreConsultant configuration. These parameters are: In shared FIFO operation:- <ul style="list-style-type: none"> • OTG_RX_DFIFO_DEPTH + OTG_TX_NPERIO_DFIFO_DEPTH In dedicated FIFO mode:- <ul style="list-style-type: none"> • OTG_RX_DFIFO_DEPTH + OTG_TX_HNPERIO_DFIFO_DEPTH 	User-selected	RO / R_W

			<p>If Enable Dynamic FIFO Sizing? was deselected in coreConsultant (parameter OTG_DFIFO_DYNAMIC = 0), these flops are optimized, and reads return the power-on value.</p> <p>If Enable Dynamic FIFO Sizing? was selected in coreConsultant (parameter OTG_DFIFO_DYNAMIC = 1), you can write a new value in this field.</p> <p>Programmed values must not exceed the power-on value set in coreConsultant.</p>		
--	--	--	---	--	--

DPTXFSIZn: Device Periodic Transmit FIFO-n Size Register

 FIFO_number: $1 \leq n \leq 15$, (Offset: $104h + (FIFO_number - 1) * 04h$)

Bits	Type	Name	Description	Mode	Initial value
31:16	RO	DPTxFSize	Device Periodic Tx FIFO Size This value is in terms of 32-bit words. <ul style="list-style-type: none"> • Minimum value is 4 • Maximum value is 768 The value of this register is the Largest Device Mode Periodic Tx Data FIFO Depth (parameter OTG_TX_DPERIO_DFIFO_DEPTH_n), as specified during coreConsultant configuration.	-	User-selected
15:0	RO / R_W	PTxFStAddr	Host Periodic Tx FIFO Start Address The power-on reset value of this register is the sum of the Largest Rx Data FIFO Depth and Largest Non-periodic Tx Data FIFO Depth specified during coreConsultant configuration. These parameters are: In shared FIFO operation:- <ul style="list-style-type: none"> • OTG_RX_DFIFO_DEPTH + OTG_TX_NPERIO_DFIFO_DEPTH In dedicated FIFO mode:- <ul style="list-style-type: none"> • OTG_RX_DFIFO_DEPTH + OTG_TX_HNPERIO_DFIFO_DEPTH If Enable Dynamic FIFO Sizing? was deselected in coreConsultant (parameter OTG_DFIFO_DYNAMIC = 0), these flops are optimized, and reads return the power-on value. If Enable Dynamic FIFO Sizing? was selected in coreConsultant (parameter OTG_DFIFO_DYNAMIC = 1), you can write a new value in this field. Programmed values must not exceed the power-on value set in coreConsultant.	-	User-selected

DIEPTXFn: Device IN Endpoint Transmit Fifo Size Register

 FIFO_number: $1 \leq n \leq 15$

 (Offset: $104h + (FIFO_number \bar{n} 1) * 04h$)

Bits	Type	Name	Description	Mode	Initial value
31:16	RO / R_W	INEPnTxFDep	IN Endpoint Tx FIFO Depth This value is in terms of 32-bit words. Minimum value is 16 Maximum value is 32,768 The power-on reset value of this register is specified as the Largest IN Endpoint FIFO	-	User-selected

			<p>number Depth (parameter OTG_TX_DINEP_DFIFO_DEPTH_n) during coreConsultant configuration ($0 < n < = 15$).</p> <p>If Enable Dynamic FIFO Sizing? was deselected in coreConsultant (parameter OTG_DFIFO_DYNAMIC = 0), these flops are optimized, and reads return the power-on value.</p> <p>If Enable Dynamic FIFO Sizing? was selected in coreConsultant (parameter OTG_DFIFO_DYNAMIC = 1), you can write a new value in this field. Programmed values must not exceed the power-on value set in coreConsultant.</p>		
15:0	RO / R_W	INEPnTxFStAddr	<p>IN Endpoint FIFO Transmit RAM Start Address</p> <p>This field contains the memory start address for IN endpoint Transmit FIFO ($0 < n < = 15$).</p> <p>The power-on reset value of this register is specified as the Largest Rx Data FIFO Depth (parameter OTG_RX_DFIFO_DEPTH) during coreConsultant configuration.</p> <p>OTG_RX_DFIFO_DEPTH + SUM 0 to n - 1 (OTG_DINEP_TXFIFO_DEPTH_n)</p> <p>For example start address of IN endpoint FIFO 1 is OTG_RX_DFIFO_DEPTH + OTG_DINEP_TXFIFO_DEPTH_0</p> <p>The start address of IN endpoint FIFO 2 is OTG_RX_DFIFO_DEPTH + OTG_DINEP_TXFIFO_DEPTH_0 + OTG_DINEP_TXFIFO_DEPTH_1</p> <p>If Enable Dynamic FIFO Sizing? was deselected in coreConsultant (parameter OTG_DFIFO_DYNAMIC = 0), these flops are optimized, and reads return the power-on value.</p> <p>If Enable Dynamic FIFO Sizing? was selected in coreConsultant (parameter OTG_DFIFO_DYNAMIC = 1), and you have programmed a new value for RxFIFO depth, you can write that value in this field. Programmed values must not exceed the power-on value set in coreConsultant.</p>	-	User-selected

DIEPTXFn: Device IN Endpoint Transmit Fifo Size Register

FIFO_number: $1 \leq n \leq 15$

(Offset: $104h + (FIFO_number \bar{n} - 1) * 04h$)

Bits	Type	Name	Description	Mode	Initial value
31:16	RO / R_W	INEPnTxFDep	<p>IN Endpoint TxFIFO Depth</p> <p>This value is in terms of 32-bit words. Minimum value is 16 Maximum value is 32,768 The power-on reset value of this register is specified as the Largest IN Endpoint FIFO number Depth (parameter TG_TX_DINEP_DFIFO_DEPTH_n) during coreConsultant configuration ($0 < n < = 15$).</p> <p>If Enable Dynamic FIFO Sizing? was deselected in coreConsultant (parameter OTG_DFIFO_DYNAMIC = 0), these flops are optimized, and reads return the power-on value.</p> <p>If Enable Dynamic FIFO Sizing? was selected in</p>	-	User-selected

			coreConsultant (parameter OTG_DFIFO_DYNAMIC = 1), you can write a new value in this field. Programmed values must not exceed the power-on value set in coreConsultant.		
15:0	RO / R_W	INEPnTxStAddr	<p>IN Endpoint FIFO Transmit RAM Start Address</p> <p>This field contains the memory start address for IN endpoint Transmit FIFO (0 < n <= 15). The power-on reset value of this register is specified as the Largest Rx Data FIFO Depth (parameter OTG_RX_DFIFO_DEPTH) during coreConsultant configuration.</p> <p>OTG_RX_DFIFO_DEPTH + SUM 0 to n - 1 (OTG_DINEP_TXFIFO_DEPTH_n)</p> <p>For example start address of IN endpoint FIFO 1 is OTG_RX_DFIFO_DEPTH + OTG_DINEP_TXFIFO_DEPTH_0</p> <p>The start address of IN endpoint FIFO 2 is OTG_RX_DFIFO_DEPTH + OTG_DINEP_TXFIFO_DEPTH_0 + OTG_DINEP_TXFIFO_DEPTH_1</p> <p>If Enable Dynamic FIFO Sizing? was deselected in coreConsultant (parameter OTG_DFIFO_DYNAMIC = 0), these flops are optimized, and reads return the power-on value.</p> <p>If Enable Dynamic FIFO Sizing? was selected in coreConsultant (parameter OTG_DFIFO_DYNAMIC = 1), and you have programmed a new value for Rx FIFO depth, you can write that value in this field. Programmed values must not exceed the power-on value set in coreConsultant.</p>	-	User-selected

HCFG: Host Configuration Register (offset: 0x400)

Bits	Type	Name	Description	Mode	Initial value
31:3	-	-	Reserved	-	30'h0
2	R/W	FSLSSupp	<p>FS- and LS-Only Support</p> <p>The application uses this bit to control the core's enumeration speed. Using this bit, the application can make the core enumerate as a FS host, even if the connected device supports HS traffic. Do not make changes to this field after initial programming.</p> <ul style="list-style-type: none"> 1'b0: HS/FS/LS, based on the maximum speed supported by the connected device 1'b1: FS/LS-only, even if the connected device can support HS 	-	1'b0
1:0	R/W	FSLSPclkSel	<p>FS/LS PHY Clock Select</p> <p>When the core is in FS Host mode</p> <ul style="list-style-type: none"> 2'b00: PHY clock is running at 30/60 MHz 2'b01: PHY clock is running at 48 MHz Others: Reserved <p>When the core is in LS Host mode</p> <ul style="list-style-type: none"> 2'b00: PHY clock is running at 30/60 MHz. <p>When the UTMI+/ULPI PHY Low Power mode is not selected, use 30/60 MHz.</p> <ul style="list-style-type: none"> 2'b01: PHY clock is running at 48 MHz. When 	-	2'b0

			<p>the UTMI+ PHY Low Power mode is selected, use 48MHz if the PHY supplies a 48 MHz clock during LS mode.</p> <ul style="list-style-type: none"> • 2'b10: PHY clock is running at 6 MHz. In USB 1.1 FS mode, use 6 MHz when the UTMI+ PHY Low Power mode is selected and the PHY supplies a 6 MHz clock during LS mode. If you select a 6 MHz clock during LS mode, you must do a soft reset. • 2'b11: Reserved 		
--	--	--	---	--	--

HFIR: Host Frame Interval Register (offset: 0x404)

Bits	Type	Name	Description	Mode	Initial value
31:16	-	-	Reserved	-	16'h0
15:0	R/W	FrInt	<p>Frame Interval</p> <p>The value that the application programs to this field specifies the interval between two consecutive SOFs (FS) or micro-SOFs (HS) or Keep-Alive tokens (HS). This field contains the number of PHY clocks that constitute the required frame interval. The default value set in this field for a FS operation when the PHY clock frequency is 60 MHz. The application can write a value to this register only after the Port Enable bit of the Host Port Control and Status register (HPRT.PrtEnaPort) has been set. If no value is programmed, the core calculates the value based on the PHY clock specified in the FS/LS PHY Clock Select field of the Host Configuration register (HCFG.FSLSPclkSel). Do not change the value of this field after the initial configuration.</p> <ul style="list-style-type: none"> • 125 μs * (PHY clock frequency for HS) • 1 ms * (PHY clock frequency for FS/LS) 	-	16'd60000

HFNUM: Host Frame Number/Frame Time Remaining Register (offset: 0x408)

Bits	Type	Name	Description	Mode	Initial value
31:16	RO	FrRem	<p>Indicates the amount of time remaining in the current microframe (HS) or frame (FS/LS), in terms of PHY clocks. This field decrements on each PHY clock. When it reaches zero, this field is reloaded with the value in the Frame Interval register and a new SOF is transmitted on the USB.</p>	-	16'h0
15:0	RO	FrNum	<p>Frame Number</p> <p>This field increments when a new SOF is transmitted on the USB, and is reset to 0 when it reaches 16'h3FFF.</p> <p>This field is writable only if Remove Optional Features? was not selected in coreConsultant (OTG_RM_OTG_FEATURES = 0). Otherwise, reads return the frame number value.</p>	-	16'h3FFF

HPTXSTS: Host Periodic Transmit FIFO/Queue Status Register (offset: 0x410)

Bits	Type	Name	Description	Mode	Initial value
31:24	RO	PTxQTop	<p>Top of the Periodic Transmit Request Queue</p> <p>This indicates the entry in the Periodic Tx</p>	-	8'h0

			<p>Request Queue currently being processes by the MAC.</p> <p>This register is used for debugging.</p> <ul style="list-style-type: none"> • Bit [31]: Odd/Even (micro)frame <ul style="list-style-type: none"> - 1'b0: send in even (micro)frame - 1'b1: send in odd (micro)frame • Bits [30:27]: Channel/endpoint number • Bits [26:25]: Type <ul style="list-style-type: none"> - 2'b00: IN/OUT - 2'b01: Zero-length packet - 2'b10: CSPLIT - 2'b11: Disable channel command • Bit [24]: Terminate (last entry for the selected channel/endpoint). 		
23:16	RO	PTxQSpAvail	<p>Periodic Transmit Request Queue Space Available</p> <p>Indicates the number of free locations available to be written in the Periodic Transmit Request Queue. This queue holds both IN and OUT requests.</p> <ul style="list-style-type: none"> • 8'h0: Periodic Transmit Request Queue is full • 8'h1: 1 location available • 8'h2: 2 locations available • n: n locations available ($0 \leq n \leq 8$) • Others: Reserved 	-	User selected
15:0	R/W	PTxFSpAvail	<p>Periodic Transmit Data FIFO Space Available</p> <p>Indicates the number of free locations available to be written to in the Periodic Tx FIFO. Values are in terms of 32-bit words</p> <ul style="list-style-type: none"> • 16'h0: Periodic Tx FIFO is full • 16'h1: 1 word available • 16'h2: 2 words available • 16'hn: n words available (where $0 \leq n \leq 32,768$) • 16'h8000: 32,768 words available • Others: Reserved 	-	User selected

HAIINT: Host All Channels Interrupt Register (offset: 0x414)

Bits	Type	Name	Description	Mode	Initial value
31:16	-	-	Reserved	-	16'h0
15:0	RO	HAIINT	Channel Interrupts One bit per channel: Bit 0 for Channel 0, bit 15 for Channel 15	-	16'h0

HPRT: Host Port Control and Status Register (offset: 0x440)

Bits	Type	Name	Description	Mode	Initial value
31:19	RO	-	Reserved	-	12'h0
18:17	RO	PrtSpd	<p>Port Speed</p> <p>Indicates the speed of the device attached to this port.</p> <ul style="list-style-type: none"> • 2'b00: High speed • 2'b01: Full speed • 2'b10: Low speed • 2'b11: Reserved 	-	2'b0
16:13	R/W	PrtTstCtl	<p>Port Test Control</p> <p>The application writes a nonzero value to this field to put the port into a Test mode, and the</p>	-	4'h0

			corresponding pattern is signaled on the port. <ul style="list-style-type: none"> • 4'b0000: Test mode disabled • 4'b0001: Test_J mode • 4'b0010: Test_K mode • 4'b0011: Test_SEO_NAK mode • 4'b0100: Test_Packet mode • 4'b0101: Test_Force_Enable • Others: Reserved 		
12	R_W_SC	PrtPwr	Port Power The application uses this field to control power to this port, and the core clears this bit on an over current condition. <ul style="list-style-type: none"> • 1'b0: Power off • 1'b1: Power on 	-	1'b0
11:10	RO	PrtLnSts	Port Line Status Indicates the current logic level USB data lines <ul style="list-style-type: none"> • Bit [10]: Logic level of D+ • Bit [11]: Logic level of D- 	-	2'b0
9	-	-	Reserved	-	1'b0
8	R/W	PrtRst	Port Reset When the application sets this bit, a reset sequence is started on this port. The application must time the reset period and clear this bit after the reset sequence is complete. <ul style="list-style-type: none"> • 1'b0: Port not in reset • 1'b1: Port in reset The application must leave this bit set for at least a minimum duration mentioned below to start a reset on the port. The application can leave it set for another 10 ms in addition to the required minimum duration, before clearing the bit, even though there is no maximum limit set by the USB standard. <ul style="list-style-type: none"> • High speed: 50 ms • Full speed/Low speed: 10 ms 	-	1'b0
7	R_WS_SC	PrtSusp	Port Suspend The application sets this bit to put this port in Suspend mode. The core only stops sending SOFs when this is set. To stop the PHY clock, the application must set the Port Clock Stop bit, which asserts the suspend input pin of the PHY. The read value of this bit reflects the current suspend status of the port. This bit is cleared by the core after a remote wakeup signal is detected or the application sets the Port Reset bit or Port Resume bit in this register or the Resume/Remote Wakeup Detected Interrupt bit or Disconnect Detected Interrupt bit in the Core Interrupt register (GINTSTS.WkUpInt or GINTSTS.DisconnInt, respectively). <ul style="list-style-type: none"> • 1'b0: Port not in Suspend mode • 1'b1: Port in Suspend mode 	-	1'b0
6	R_W_	PrtRes	Port Resume	-	1'b0

	SS_SC		<p>The application sets this bit to drive resume signaling on the port. The core continues to drive the resume signal until the application clears this bit.</p> <p>If the core detects a USB remote wakeup sequence, as indicated by the Port Resume/Remote Wakeup Detected Interrupt bit of the Core Interrupt register (GINTSTS.WkUpInt), the core starts driving resume signaling without application intervention and clears this bit when it detects a disconnect condition. The read value of this bit indicates whether the core is currently driving resume signaling.</p> <ul style="list-style-type: none"> • 1'b0: No resume driven • 1'b1: Resume driven 		
5	R_SS_WC	PrtOvrCurrChng	<p>Port Overcurrent Change</p> <p>The core sets this bit when the status of the Port Overcurrent Active bit (bit 4) in this register changes.</p>	-	1'b0
4	RO	PrtOvrCurrAct	<p>Port Overcurrent Active</p> <p>Indicates the overcurrent condition of the port.</p> <ul style="list-style-type: none"> • 1'b0: No overcurrent condition • 1'b1: Overcurrent condition 	-	1'b0
3	R_SS_WC	PrtEnChng	<p>Port Enable/Disable Change</p> <p>The core sets this bit when the status of the Port Enable bit [2] of this register changes.</p>	-	1'b0
2	R_SS_SC_WC	PrtEna	<p>Port Enable</p> <p>A port is enabled only by the core after a reset sequence, and is disabled by an over current condition, a disconnect condition, or by the application clearing this bit. The application cannot set this bit by a register write. It can only clear it to disable the port. This bit does not trigger any interrupt to the application.</p> <ul style="list-style-type: none"> • 1'b0: Port disabled • 1'b1: Port enabled 	-	1'b0
1	R_SS_WC	PrtConnDet	<p>Port Connect Detected</p> <p>The core sets this bit when a device connection is detected to trigger an interrupt to the application using the Host Port Interrupt bit of the Core Interrupt register (GINTSTS.PrtInt). The application must write a 1 to this bit to clear the interrupt.</p>	-	1'b0
0	RO	PrtConnSts	<p>Port Connect Status</p> <ul style="list-style-type: none"> • 0: No device is attached to the port. • 1: A device is attached to the port. 		1'b0

HCCHARn: Host Channel-n Characteristics Register

 Channel_number: $0 \leq n \leq 15$

 (Offset: $500h + (\text{Channel_number} * 20h)$)

Bits	Type	Name	Description	Mode	Initial value
31	R_WS_SC	ChEna	<p>Channel Enable</p> <p>This field is set by the application and cleared by the OTG host</p> <ul style="list-style-type: none"> • 1'b0: Channel disabled 	-	1'b0

			<ul style="list-style-type: none"> • 1'b1: Channel enabled 		
30	R_WS _SC	ChDis	Channel Disable The application sets this bit to stop transmitting/receiving data on a channel, even before the transfer for that channel is complete. The application must wait for the Channel Disabled interrupt before treating the channel as disabled.	-	1'b0
29	R/W	OddFrm	Odd Frame This field is set (reset) by the application to indicate that the OTG host must perform a transfer in an odd (micro) frame. This field is applicable for only periodic (isochronous and interrupt) transactions. <ul style="list-style-type: none"> • 1'b0: Even (micro)frame • 1'b1: Odd (micro)frame 	-	1'b0
28:22	R/W	DevAddr	Device Address This field selects the specific device serving as the data source or sink.	-	7'h0
21:20	R/W	MC/ EC	Multi Count/ / Error Count When the Split Enable bit of the Host Channel-n Split Control register (HCSPLTn.SpltEna) is reset (1'b0), this field indicates to the host the number of transactions that must be executed per microframe for this periodic endpoint. For non periodic transfers, this field is used only in DMA mode, and specifies the number packets to be fetched for this channel before the internal DMA engine changes arbitration. <ul style="list-style-type: none"> • 2'b00: Reserved This field yields undefined results. • 2'b01: 1 transaction • 2'b10: 2 transactions to be issued for this endpoint per microframe • 2'b11: 3 transactions to be issued for this endpoint per microframe When HCSPLTn.SpltEna is set (1'b1), this field indicates the number of immediate retries to be performed for a periodic split transactions on transaction errors. This field must be set to at least 2'b01.	-	2'b0
19:18	R/W	EPTYPE	Endpoint Type Indicates the transfer type selected. <ul style="list-style-type: none"> • 2'b00: Control • 2'b01: Isochronous • 2'b10: Bulk • 2'b11: Interrupt 	-	2'b0
17	R/W	LSpdDev	Low-Speed Device This field is set by the application to indicate that this channel is communicating to a low-speed device.	-	1'b0
16	-	-	Reserved	-	1'b0
15	R/W	EPDir	Endpoint Direction Indicates whether the transaction is IN or OUT. <ul style="list-style-type: none"> • 1'b0: OUT 	-	1'b0

			• 1'b1: IN		
14:11	R/W	EPNum	Endpoint Number Indicates the endpoint number on the device serving as the data source or sink.	-	4'h0
10:0	R/W	MPS	Maximum Packet Size Indicates the maximum packet size of the associated endpoint.	-	11'h0

HCSPLTn: Host Channel-n Split Control Register

 Channel_number: $0 \leq n \leq 15$

 (Offset: $504h + (\text{Channel_number} * 20h)$)

Bits	Type	Name	Description	Mode	Initial value
31	R/W	SpltEna	Split Enable The application sets this field to indicate that this channel is enabled to perform split transactions.	-	1'b0
30:17	-	-	Reserved	-	14'h0
16	R/W	CompSplt	Do Complete Split The application sets this field to request the OTG host to perform a complete split transaction.	-	1'b0
15:14	R/W	XactPos	Transaction Position This field is used to determine whether to send all, first, middle, or last payloads with each OUT transaction. <ul style="list-style-type: none"> • 2'b11: All. This is the entire data payload is of this transaction (which is less than or equal to 188 bytes). • 2'b10: Begin. This is the first data payload of this transaction (which is larger than 188 bytes). • 2'b00: Mid. This is the middle payload of this transaction (which is larger than 188 bytes). • 2'b01: End. This is the last payload of this transaction (which is larger than 188 bytes). 	-	2'h0
13:7	R/W	HubAddr	Hub Address This field holds the device address of the transaction translator's hub.	-	7'h0
6:0	R/W	PrtAddr	Port Address This field is the port number of the recipient transaction translator.	-	7'h0

HCINTn: Host Channel-n Interrupt Register

 Channel_number: $0 \leq n \leq 15$

 (Offset: $508h + (\text{Channel_number} * 20h)$)

Bits	Type	Name	Description	Mode	Initial value
31:11	-	-	Reserved	-	21'h0
10	R_SS_WC	DataTglEr	Data Toggle Error	-	1'b0
9	R_SS_WC	FrmOvrn	Frame Overrun	-	1'b0
8	R_SS_WC	BblErr	Babble Error	-	1'b0
7	R_SS_WC	XactErr	Transaction Error Indicates one of the following errors occurred on the USB.	-	1'b0

			<ul style="list-style-type: none"> • CRC check failure • Timeout • Bit stuff error • False EOP 		
6	R_SS_WC	NYET	NYET Response Received Interrupt	-	1'b0
5	R_SS_WC	ACK	ACK Response Received/Transmitted Interrupt	-	1'b0
4	R_SS_WC	NAK	NAK Response Received Interrupt	-	1'b0
3	R_SS_WC	STALL	STALL Response Received Interrupt	-	1'b0
2	R_SS_WC	AHBErr	AHB Error This is generated only in Internal DMA mode when there is an AHB error during AHB read/write. The application can read the corresponding channel's DMA address register to get the error address.	-	1'b0
1	R_SS_WC	ChHltd	Channel Halted Indicates the transfer completed abnormally either because of any USB transaction error or in response to disable request by the application.	-	1'b0
0	R_SS_WC	XferCompl	Transfer Completed Transfer completed normally without any errors.	-	1'b0

HCINTMSKn: Host Channel-n Interrupt Mask Register

Channel_number: $0 \leq n \leq 15$

(Offset: $50Ch + (\text{Channel_number} * 20h)$)

Bits	Type	Name	Description	Mode	Initial value
31:11	-	-	Reserved	-	21'h0
10	R/W	DataTglErrMsk	Data Toggle Error Mask	-	1'b0
9	R/W	FrmOvrnMsk	Frame Overrun Mask	-	1'b0
8	R/W	BblErrMsk	Babble Error Mask	-	1'b0
7	R/W	XactErrMsk	Transaction Error Mask	-	1'b0
6	R/W	NyetMsk	NYET Response Received Interrupt Mask	-	1'b0
5	R/W	AckMsk	ACK Response Received/Transmitted Interrupt Mask	-	1'b0
4	R/W	NakMsk	NAK Response Received Interrupt Mask	-	1'b0
3	R/W	StallMsk	STALL Response Received Interrupt Mask	-	1'b0
2	R/W	AHBErrMsk	AHB Error Mask	-	1'b0
1	R/W	ChHltdMsk	Channel Halted Mask	-	1'b0
0	R/W	XferComplMsk	Transfer Completed Mask	-	1'b0

HCTSIZn: Host Channel-n Interrupt Mask Register

Channel_number: $0 \leq n \leq 15$

(Offset: $510h + (\text{Channel_number} * 20h)$)

Bits	Type	Name	Description	Mode	Initial value
31	R/W	DoPng	Setting this field to 1 directs the host to do PING protocol	-	1'h0
30:29	R/W	Pid	PID The application programs this field with the type of PID to use for the initial transaction. The host maintains this field for the rest of the transfer.	-	2'b0

			<ul style="list-style-type: none"> • 2'b00: DATA0 • 2'b01: DATA2 • 2'b10: DATA1 • 2'b11: MDATA (non-control)/SETUP (control) 		
28:19	R/W	PktCnt	<p>Packet Count</p> <p>This field is programmed by the application with the expected number of packets to be transmitted (OUT) or received (IN). The host decrements this count on every successful transmission or reception of an OUT/IN packet. Once this count reaches zero, the application is interrupted to indicate normal completion.</p> <p>The width of this counter is specified as Width of Packet Counters during coreConsultant configuration (parameter OTG_PACKET_COUNT_WIDTH).</p>	-	10'b0
18:0	R/W	XferSize	<p>Transfer Size</p> <p>For an OUT, this field is the number of data bytes the host sends during the transfer. For an IN, this field is the buffer size that the application has Reserved for the transfer. The application is expected to program this field as an integer multiple of the maximum packet size for IN transactions (periodic and non-periodic). The width of this counter is specified as Width of Transfer Size Counters during coreConsultant configuration (parameter OTG_TRANS_COUNT_WIDTH).</p>	-	19'b0

HCDMA: Host Channel-n DMA Address Register

 Channel_number: $0 \leq n \leq 15$

 (Offset: $514h + (\text{Channel_number} * 20h)$)

Bits	Type	Name	Description	Mode	Initial value
31:0	R/W	DMAAddr	<p>DMA Address</p> <p>This field holds the start address in the external memory from which the data for the endpoint must be fetched or to which it must be stored. This register is incremented on every AHB transaction.</p>	-	32'h0

DCFG: Device Configuration Register (offset: 0x800)

Bits	Type	Name	Description	Mode	Initial value
31:23	-	-	Reserved	-	9'h0
22:18	R/W	EPMisCnt	<p>IN Endpoint Mismatch Count</p> <p>This field is valid only in shared FIFO operation. The application programs this field with a count that determines when the core generates an Endpoint Mismatch interrupt (GINTSTS.EPMis). The core loads this value into an internal counter and decrements it. The counter is reloaded whenever there is a match or when the counter expires. The width of this counter depends on the depth of the Token Queue.</p>	-	5'h8
17:13	-	-	Reserved	-	5'h0

12:11	R/W	PerFrInt	<p>Periodic Frame Interval</p> <p>Indicates the time within a (micro) frame at which the application must be notified using the End Of Periodic Frame Interrupt. This can be used to determine if all the isochronous traffic for that (micro) frame is complete.</p> <ul style="list-style-type: none"> • 2'b00: 80% of the (micro)frame interval • 2'b01: 85% • 2'b10: 90% • 2'b11: 95% 	-	2'h0
10:4	R/W	DevAddr	<p>Device Address</p> <p>The application must program this field after every SetAddress control command.</p>	-	7'h0
3	-	-	Reserved	-	1'b0
2	R/W	NZStsOUTHShk	<p>Non-Zero-Length Status OUT Handshake</p> <p>The application can use this field to select the handshake the core sends on receiving a nonzero-length data packet during the OUT transaction of a control transfer's Status stage.</p> <ul style="list-style-type: none"> • 1'b1: Send a STALL handshake on a nonzero-length status OUT transaction and do not send the received OUT packet to the application. • 1'b0: Send the received OUT packet to the application (zero-length or nonzero-length) and send a handshake based on the NAK and STALL bits for the endpoint in the Device Endpoint Control register. 	-	1'b0
1:0	R/W	DevSpd	<p>Device Speed</p> <p>Indicates the speed at which the application requires the core to enumerate, or the maximum speed the application can support. However, the actual bus speed is determined only after the chirp sequence is completed, and is based on the speed of the USB host to which the core is connected. See "Device Initialization" on page 297 for details.</p> <ul style="list-style-type: none"> • 2'b00: High speed (USB 2.0 PHY clock is 30 MHz or 60 MHz) • 2'b01: Full speed (USB 2.0 PHY clock is 30 MHz or 60 MHz) • 2'b10: Low speed (USB 1.1 transceiver clock is 6 MHz). If you select 6 MHz LS mode, you must do a soft reset • 2'b11: Full speed (USB 1.1 transceiver clock is 48 MHz) 	-	2'b0

DCTL: Device Control Register (offset: 0x804)

Bits	Type	Name	Description	Mode	Initial value
31:12	-	-	Reserved	-	20'h0
11	R/W	PWROnPrdDone	<p>Power-On Programming Done</p> <p>The application uses this bit to indicate that register programming is completed after a wake-up from Power Down mode. For more information, see "Device Mode Suspend and Resume With Partial Power-Down" on page 422.</p>	-	1'b0

10	WO	CGOUTNak	<p>Clear Global OUT NAK A write to this field clears the Global OUT NAK.</p>	-	1'b0
9	WO	SGOUTNak	<p>Set Global OUT NAK A write to this field sets the Global OUT NAK. The application uses this bit to send a NAK handshake on all OUT endpoints. The application must set the bit only after making sure that the Global OUT NAK Effective bit in the Core Interrupt Register (GINTSTS.GOUTNakEff) is cleared.</p>	-	1'b0
8	WO	CGNPinNak	<p>Clear Global Non-periodic IN NAK A write to this field clears the Global Non-periodic IN NAK.</p>	-	1'b0
7	WO	SGNPinNak	<p>Set Global Non-periodic IN NAK A write to this field sets the Global Non-periodic IN NAK. The application uses this bit to send a NAK handshake on all non-periodic IN endpoints. The core can also set this bit when a timeout condition is detected on a non-periodic endpoint in shared FIFO operation. The application must set this bit only after making sure that the Global IN NAK Effective bit in the Core Interrupt Register (GINTSTS.GINNakEff) is cleared.</p>	-	1'b0
6:4	R/W	TstCtl	<p>Test Control</p> <ul style="list-style-type: none"> • 3'b000: Test mode disabled • 3'b001: Test_J mode • 3'b010: Test_K mode • 3'b011: Test_SEO_NAK mode • 3'b100: Test_Packet mode • 3'b101: Test_Force_Enable • Others: Reserved 	-	3'b0
3	RO	GOUTNakSts	<p>Global OUT NAK Status</p> <ul style="list-style-type: none"> • 1'b0: A handshake is sent based on the FIFO Status and the NAK and STALL bit settings. • 1'b1: No data is written to the RxFIFO, irrespective of space availability. Sends a NAK handshake on all packets, except on SETUP transactions. All isochronous OUT packets are dropped. 	-	1'b0
2	RO	GNPINNakSts	<p>Global Non-periodic IN NAK Status</p> <ul style="list-style-type: none"> • 1'b0: A handshake is sent out based on the data availability in the transmit FIFO. • 1'b1: A NAK handshake is sent out on all non-periodic IN endpoints, irrespective of the data availability in the transmit FIFO. 	-	1'b0
1	R/W	SftDiscon	<p>Soft Disconnect The application uses this bit to signal the DWC_otg core to do a soft disconnect. As long as this bit is set, the host does not see that the device is connected, and the device does not receive signals on the USB. The core stays in the disconnected state until the application clears this bit.</p>	-	1'b0

			<p>The minimum duration for which the core must keep this bit set is specified in Table 5-45.</p> <ul style="list-style-type: none"> 1'b0: Normal operation. When this bit is cleared after a soft disconnect, the core drives the phy_opmode_o signal on the UTMI+ to 2'b00, which generates a device connect event to the USB host. When the device is reconnected, the USB host restarts device enumeration. 1'b1: The core drives the phy_opmode_o signal on the UTMI+ to 2'b01, which generates a device disconnect event to the USB host. 		
0	R/W	RmtWkUpSig	<p>Remote Wakeup Signaling</p> <p>When the application sets this bit, the core initiates remote signaling to wake up the USB host.</p> <p>The application must set this bit to instruct the core to exit the Suspend state. As specified in the USB 2.0 specification, the application must clear this bit 1–15 ms after setting it.</p>	-	1'b0

DSTS: Device Status Register (offset: 0x808)

Bits	Type	Name	Description	Mode	Initial value
31:22	-	-	Reserved	-	10'h0
21:8	RO	SOFFN	<p>Frame or Microframe Number of the Received SOF</p> <p>When the core is operating at high speed, this field contains a microframe number. When the core is operating at full or low speed, this field contains a frame number.</p>	-	14'h0
7:4	-	-	Reserved	-	4'h0
3	RO	ErrticErr	<p>Erratic Error</p> <p>The core sets this bit to report any erratic errors (phy_rxvalid_i/ phy_rxvldh_i or phy_rxactive_i is asserted for at least 2 ms, due to PHY error) seen on the UTMI+ .</p> <p>Due to erratic errors, the DWC_otg core goes into Suspended state and an interrupt is generated to the application with Early Suspend bit of the Core Interrupt register (GINTSTS.ErlySusp). If the early suspend is asserted due to an erratic error, the application can only perform a soft disconnect recover</p>	-	1'b0
2:1	RO	EnumSpd	<p>Enumerated Speed</p> <p>Indicates the speed at which the DWC_otg core has come up after speed detection through a chirp sequence.</p> <ul style="list-style-type: none"> 2'b00: High speed (PHY clock is running at 30 or 60 MHz) 2'b01: Full speed (PHY clock is running at 30 or 60 MHz) 2'b10: Low speed (PHY clock is running at 6 MHz) 2'b11: Full speed (PHY clock is running at 48 MHz) Low speed is not supported for devices 	-	2'h01

			using a UTMI+ PHY.		
0	RO	SuspSts	<p>Suspend Status</p> <p>In Device mode, this bit is set as long as a Suspend condition is detected on the USB. The core enters the Suspended state when there is no activity on the phy_line_state_i signal for an extended period of time. The core comes out of the suspend:</p> <ul style="list-style-type: none"> When there is any activity on the phy_line_state_i signal When the application writes to the Remote Wakeup Signaling bit in the Device Control register (DCTL.RmtWkUpSig). 	-	1'b0

DIEPMSK: Device IN Endpoint Common Interrupt Mask Register (offset: 0x810)

Bits	Type	Name	Description	Mode	Initial value
31:9	-	-	Reserved	-	23'h0
8	R/W	TxfifoUndrnMsk	Fifo Underrun Mask	-	1'b0
7	R/W	-	Reserved	-	1'b0
6	R/W	INEPNakEffMsk	IN Endpoint NAK Effective Mask	-	1'b0
5	R/W	INTknEPMisMsk	IN Token received with EP Mismatch Mask	-	1'b0
4	R/W	INTknTXFEmpMsk	IN Token Received When Tx FIFO Empty Mask	-	1'b0
3	R/W	TimeOUTMsk	Timeout Condition Mask (Non-isochronous endpoints)	-	1'b0
2	R/W	AHBErrMsk	AHB Error Mask	-	1'b0
1	R/W	EPDisbldMsk	Endpoint Disabled Interrupt Mask	-	1'b0
0	R/W	XferComplMsk	Transfer Completed Interrupt Mask	-	1'b0

DOEPMASK: Device OUT Endpoint Common Interrupt Mask Register (offset: 0x814)

Bits	Type	Name	Description	Mode	Initial value
31:9	-	-	Reserved	-	23'h0
8	R/W	OutPktErrMsk	OUT Packet Error Mask	-	1'b0
7	-	-	Reserved	-	1'b0
6	R/W	Back2BackSETup	Back-to-Back SETUP Packets Received Mask Applies to control OUT endpoints only.	-	1'b0
5	-	-	Reserved	-	1'b0
4	R/W	OUTTknEPdisMsk	OUT Token Received when Endpoint Disabled Mask Applies to control OUT endpoints only.	-	1'b0
3	R/W	SetUPMsk	SETUP Phase Done Mask Applies to control endpoints only.	-	1'b0
2	R/W	AHBErrMsk	AHB Error	-	1'b0
1	R/W	EPDisbldMsk	Endpoint Disabled Interrupt Mask	-	1'b0
0	R/W	XferComplMsk	Transfer Completed Interrupt Mask	-	1'b0

DAINT: Device All Endpoints Interrupt Register (offset: 0x818)

Bits	Type	Name	Description	Mode	Initial value
31:16	RO	OutEPInt	OUT Endpoint Interrupt Bits One bit per OUT endpoint: Bit 16 for OUT endpoint 0, bit 31 for OUT endpoint 15	-	16'h0
15:0	RO	InEPInt	IN Endpoint Interrupt Bits One bit per IN Endpoint: Bit 0 for IN endpoint 0, bit 15 for endpoint 15	-	16'h0

DAINTMSK: Device Endpoints Interrupt Mask Register (offset: 0x81c)

Bits	Type	Name	Description	Mode	Initial value
31:16	R/W	OutEpMsk	OUT EP Interrupt Mask Bits One per OUT Endpoint: Bit 16 for OUT EP 0, bit 31 for OUT EP 15	-	16'h0
15:0	R/W	InEpMsk	IN EP Interrupt Mask Bits One bit per IN Endpoint: Bit 0 for IN EP 0, bit 15 for IN EP 15	-	16'h0

DTKNQR1: Device IN Token Sequence Learning Queue Read Register 1 (offset: 0x820)

Bits	Type	Name	Description	Mode	Initial value
31:8	RO	EPTkn	Endpoint Token Four bits per token represent the endpoint number of the token: <ul style="list-style-type: none"> • Bits [31:28]: Endpoint number of Token 5 • Bits [27:24]: Endpoint number of Token 4 • Bits [15:12]: Endpoint number of Token 1 • Bits [11:8]: Endpoint number of Token 0 	-	24'h0
7	RO	WrapBit	Wrap Bit This bit is set when the write pointer wraps. It is cleared when the learning queue is cleared.	-	1'b0
6:5	RO	-	Reserved	-	2'h0
4:0	RO	INTknWPtr	IN Token Queue Write Pointer	-	5'h0

DTKNQR2: Device IN Token Sequence Learning Queue Register 2 (offset: 0x824)

Bits	Type	Name	Description	Mode	Initial value
31:0	RO	EPTkn	Endpoint Token Four bits per token represent the endpoint number of the token: <ul style="list-style-type: none"> • Bits [31:28]: Endpoint number of Token 13 • Bits [27:24]: Endpoint number of Token 12 • Bits [7:4]: Endpoint number of Token 7 • Bits [3:0]: Endpoint number of Token 6 	-	32'h0

DTKNQR3: Device IN Token Sequence Learning Queue Register 3 (offset: 0x830)

Bits	Type	Name	Description	Mode	Initial value
31:0	RO	EPTkn	Endpoint Token Four bits per token represent the endpoint number of the token: <ul style="list-style-type: none"> • Bits [31:28]: Endpoint number of Token 21 • Bits [27:24]: Endpoint number of Token 20 • Bits [7:4]: Endpoint number of Token 15 • Bits [3:0]: Endpoint number of Token 14 	-	32'h0

DTKNQR4: Device IN Token Sequence Learning Queue Register 4 (offset: 0x834)

Bits	Type	Name	Description	Mode	Initial value
31:0	RO	EPTkn	Endpoint Token Four bits per token represent the endpoint number of the token: <ul style="list-style-type: none"> • Bits [31:28]: Endpoint number of Token 29 • Bits [27:24]: Endpoint number of Token 28 • Bits [7:4]: Endpoint number of Token 23 • Bits [3:0]: Endpoint number of Token 22 	-	32'h0

DVBUSDIS: Device VBUS Discharge Time Register (offset: 0x0828)

Bits	Type	Name	Description	Mode	Initial value
31:16	-	-	Reserved	-	16'h0
15:0	R/W	DVBUSDis	Device VBUS Discharge Time Specifies the VBUS discharge time after VBUS pulsing during SRP. This value equals: VBUS discharge time in PHY clocks / 1, 024 The value you use depends whether the PHY is operating at 30 MHz (16-bit data width) or 60 MHz (8-bit data width). Depending on your VBUS load, this value can need adjustment.	-	30 MHz: 16'h0B8F 60 MHz: 16'h17D7

DVBUSPULSE: Device VBUS Pulsing Time Register (offset: 0x082c)

Bits	Type	Name	Description	Mode	Initial value
31:12	-	-	Reserved	-	20'h0
11:0	R/W	DVBUSPulse	Device VBUS Pulsing Time Specifies the VBUS pulsing time during SRP. This value equals: VBUS pulsing time in PHY clocks / 1, 024 The value you use depends whether the PHY is operating at 30 MHz (16-bit data width) or 60 MHz (8-bit data width).	-	30 MHz: 12'h2C6 60 MHz: 12'h5B8

DTHRCTL: Device Threshold Control Register (offset: 0x830)

Bits	Type	Name	Description	Mode	Initial value
31:28	-	-	Reserved	-	4'b0
27	R/W	ArbPrkEn	Arbiter Parking Enable This bit controls internal DMA arbiter parking for IN endpoints. When thresholding is enabled and this bit is set to one, then the arbiter parks on the IN endpoint for which there is a token received on the USB. This is done to avoid getting into underrun conditions. By default the parking is enabled.	-	1'b1
26	-	-	Reserved	-	1'b1
25:17	R/W	RxThrLen	Receive Threshold Length This field specifies Receive thresholding size in DWORDS. This field also specifies the amount of data received on the USB before the core can start transmitting on the AHB. The threshold length has to be at least eight DWORDS. The recommended value for ThrLen is to be the same as the programmed AHB Burst Length (GAHB_CFG.HBstLen).	-	9'h8
16	R/W	RxThrEn	Receive Threshold Enable When this bit is set, the core enables thresholding in the receive direction.	-	1'b0
15:11	-	-	Reserved	-	5'b0
10:2	R/W	TxThrLen	Transmit Threshold Length This field specifies Transmit thresholding size in DWORDS. This field specifies the amount of data in bytes to be in the corresponding endpoint transmit FIFO, before the core can start transmit on the USB.	-	9'h8

			The threshold length has to be at least eight DWORDS. This field controls both isochronous and non-isochronous IN endpoint thresholds. The recommended value for ThrLen is to be the same as the programmed AHB Burst Length (GAHBCFG.HBstLen).		
1	R/W	ISOThrEn	ISO IN Endpoints Threshold Enable. When this bit is set, the core enables thresholding for isochronous IN endpoints.	-	1'b0
0	R/W	NonISOThrEn	Non-ISO IN Endpoints Threshold Enable. When this bit is set, the core enables thresholding for Non Isochronous IN endpoints.	-	1'b0

DIEPEMPMSK: Device IN Endpoint FIFO Empty Interrupt Mask Register (offset: 0x834)

Bits	Type	Name	Description	Mode	Initial value
31:16	RO	-	Reserved	-	16'h0
15:0	R/W	InEpTxfEmpMsk	IN EP Tx FIFO Empty Interrupt Mask Bits These bits act as mask bits for DIEPINTn. TxFEmp interrupt One bit per IN Endpoint: Bit 0 for IN EP 0, bit 15 for IN EP 15	-	16'h0

DIEPCTL0: Device Control IN Endpoint 0 Control Register (offset: 0x900)

Bits	Type	Name	Description	Mode	Initial value
31	R/WS /SC	EPEna	Endpoint Enable Indicates that data is ready to be transmitted on the endpoint. The core clears this bit before setting any of the following interrupts on this endpoint: <ul style="list-style-type: none"> • Endpoint Disabled • Transfer Completed 	-	1'b0
30	R/WS /SC	EPDis	Endpoint Disable The application sets this bit to stop transmitting data on an endpoint, even before the transfer for that endpoint is complete. The application must wait for the Endpoint Disabled interrupt before treating the endpoint as disabled. The core clears this bit before setting the Endpoint Disabled Interrupt. The application must set this bit only if Endpoint Enable is already set for this endpoint.	-	1'b0
29:28	-	-	Reserved	-	2'b0
27	WO	SNAK	Set NAK A write to this bit sets the NAK bit for the endpoint. Using this bit, the application can control the transmission of NAK handshakes on an endpoint. The core can also set this bit for an endpoint after a SETUP packet is received on that endpoint.	-	1'b0
26	WO	CNAK	Clear NAK A write to this bit clears the NAK bit for the endpoint.	-	1'b0
25:22	R/W	TxFNum	TxFIFO Number <ul style="list-style-type: none"> • For Shared FIFO operation, this value is always set to 0, indicating that control IN endpoint 0 data is always written in the Non-Periodic Transmit FIFO. 	-	4'h0

			<ul style="list-style-type: none"> For Dedicated FIFO operation, this value is set to the FIFO number that is assigned to IN Endpoint 0. 		
21	R/WS /SC	Stall	STALL Handshake The application can only set this bit, and the core clears it, when a SETUP token is received for this endpoint. If a NAK bit, Global Non-periodic IN NAK, or Global OUT NAK is set along with this bit, the STALL bit takes priority.	-	1'b0
20	-	-	Reserved	-	1'b0
19:18	RO	EPTYPE	Endpoint Type Hardcoded to 00 for control.	-	2'h0
17	RO	NAKSts	NAK Status Indicates the following: <ul style="list-style-type: none"> 1'b0: The core is transmitting non-NAK handshakes based on the FIFO status 1'b1: The core is transmitting NAK handshakes on this endpoint. When this bit is set, either by the application or core, the core stops transmitting data, even if there is data available in the TxFIFO. Irrespective of this bit's setting, the core always responds to SETUP data packets with an ACK handshake.	-	1'b0
16	-	-	Reserved	-	1'b0
15	RO	USBActEP	USB Active Endpoint This bit is always set to 1, indicating that control endpoint 0 is always active in all configurations and interfaces.	-	1'b1
14:11	R/W	NextEp	Next Endpoint Applies to non-periodic IN endpoints only. Indicates the endpoint number to be fetched after the data for the current endpoint is fetched. The core can access this field, even when the Endpoint Enable (EPEna) bit is not set. This field is not valid in Slave mode. Note: This field is valid only for Shared FIFO operations.	-	4'b0
10:2	-	-	Reserved	-	9'h0
1:0	R/W	MPS	Maximum Packet Size Applies to IN and OUT endpoints. The application must program this field with the maximum packet size for the current logical endpoint. <ul style="list-style-type: none"> 2'b00: 64 bytes 2'b01: 32 bytes 2'b10: 16 bytes 2'b11: 8 bytes 	-	2'h0

3.20 802.11n 1T1R MAC/BBP

3.20.1 Features

- 1x1 modes
- 300MHz PHY Rate Support
- Legacy and High Throughput Modes
- 20MHz/40MHz bandwidth
- Reverse Direction Data Flow and Frame Aggregation
- WEP 64/128, WPA, WPA2 Support
- QoS – WMM, WMM-PS
- Wake on Wireless LAN
- Multiple BSSID Support
- International Regulation - 802.11d+h
- Cisco CCX V1.0 V2.0 V3.0 Compliance
- Bluetooth Co-existence
- Low Power with Advanced Power Management

3.20.2 Block Diagram

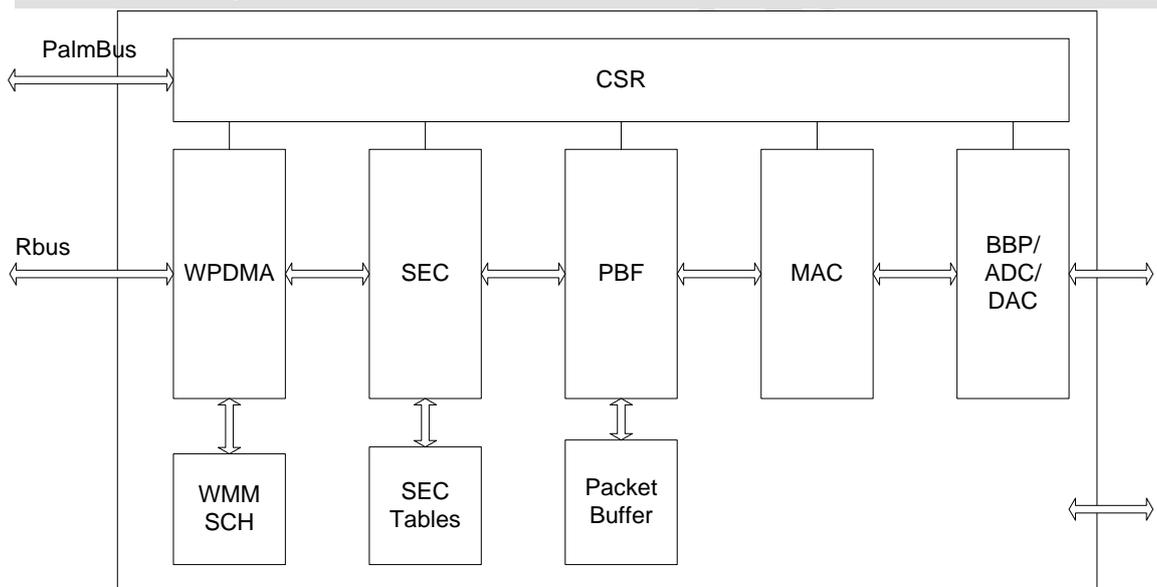

Fig. 3-20-1 802.11n 1T1R MAC/BBP Block Diagram

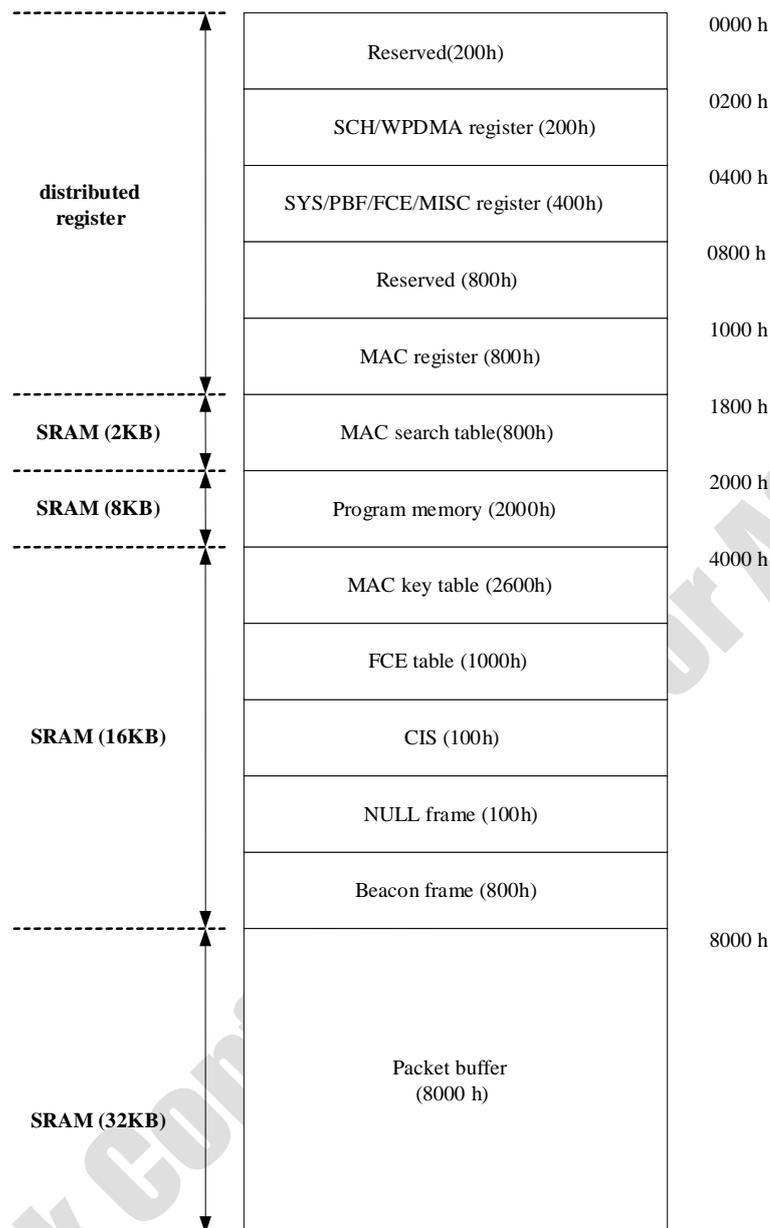

Fig. 3-20-2 802.11n 1T1R MAC/BBP Register Map

3.20.3 Register Description (base: 0x1018.0000)

3.20.3.1 Register Description - SCH/WPDMA (base: 1018.0000)

INT_STATUS: INT_STATUS Register (offset: 0x0200)

Bits	Type	Name	Description	Initial value
31:21	-	-	Reserved	0
20	R/W	RADAR_INT	BBP radar detection interrupt	0
19:18	-	-	Reserved	0
17	R/W	TX_COHERENT	TX_DMA finds data coherent event when checking ddone bit. Write 1 to clear the interrupt. Read to get the raw interrupt status	0
16	R/W	RX_COHERENT	RX_DMA finds data coherent event when checking ddone bit. Write 1 to clear the interrupt. Read to get the raw interrupt status	0
15	R/W	MAC_INT_4	MAC interrupt 4: GP timer interrupt	0

14	R/W	MAC_INT_3	MAC interrupt 3: Auto wakeup interrupt	0
13	R/W	MAC_INT_2	MAC interrupt 2: TX status interrupt	0
12	R/W	MAC_INT_1	MAC interrupt 1: Pre-TBTT interrupt	0
11	R/W	MAC_INT_0	MAC interrupt 0: TBTT interrupt	0
10	RO	TX_RX_COHERENT	When TX_COHERENT or RX_COHERENT is on, this bit is set	0
9	R/W	MCU_CMD_INT	MCU command interrupt	0
8	R/W	TX_DONE_INT5	TX Queue#5 packet transmit interrupt Write 1 to clear the interrupt.	0
7	R/W	TX_DONE_INT4	TX Queue#4 packet transmit interrupt Write 1 to clear the interrupt. Read to get the raw interrupt status	0
6	R/W	TX_DONE_INT3	TX Queue#3 packet transmit interrupt Write 1 to clear the interrupt. Read to get the raw interrupt status	0
5	R/W	TX_DONE_INT2	TX Queue#2 packet transmit interrupt Write 1 to clear the interrupt. Read to get the raw interrupt status	0
4	R/W	TX_DONE_INT1	TX Queue#1 packet transmit interrupt Write 1 to clear the interrupt. Read to get the raw interrupt status	0
3	R/W	TX_DONE_INT0	TX Queue#0 packet transmit interrupt Write 1 to clear the interrupt. Read to get the raw interrupt status	0
2	R/W	RX_DONE_INT	RX packet receive interrupt Write 1 to clear the interrupt. Read to get the raw interrupt status	0
1	R/W	TX_DLY_INT	Summary of the whole WPDMA TX related interrupts Write 1 to clear the interrupt. Read to get the raw interrupt status	0
0	R/W	RX_DLY_INT	Summary of the whole WPDMA RX related interrupts Write 1 to clear the interrupt. Read to get the raw interrupt status	0

INT_MASK: INT_MASK Register (offset: 0x0204)

Bits	Type	Name	Description	Initial value
31:18	-	-	Reserved	0
20	R/W	RADAR_INT_EN	Enable for BBP radar detection interrupt 1: Enable the interrupt 0: Disable the interrupt	0
19:18	-	-	Reserved	0
17	R/W	TX_COHERENT_EN	Enable for TX_DMA data coherent interrupt 1: Enable the interrupt 0: Disable the interrupt	0
16	R/W	RX_COHERENT_EN	Enable for RX_DMA data coherent interrupt 1: Enable the interrupt 0: Disable the interrupt	0
14	R/W	MAC_INT4_EN	MAC interrupt 4: GP timer interrupt	0
14	R/W	MAC_INT3_EN	MAC interrupt 3: Auto wakeup interrupt	0
13	R/W	MAC_INT2_EN	MAC interrupt 2: TX status interrupt	0
12	R/W	MAC_INT1_EN	MAC interrupt 1: Pre-TBTT interrupt	0
11	R/W	MAC_INT0_EN	MAC interrupt 0: TBTT interrupt	0
10	-	-	Reserved	0
9	R/W	MCU_CMD_INT_	MCU command interrupt enable	0

		MSK	1: Enable the interrupt 0: Disable the interrupt	
8	R/W	TX_DONE_INT_MSK5	TX Queue#5 packet transmit interrupt 1: Enable the interrupt 0: Disable the interrupt	0
7	R/W	TX_DONE_INT_MSK4	TX Queue#4 packet transmit interrupt 1: Enable the interrupt 0: Disable the interrupt	0
6	R/W	TX_DONE_INT_MSK 3	TX Queue#3 packet transmit interrupt 1: Enable the interrupt 0: Disable the interrupt	0
5	R/W	TX_DONE_INT_MSK 2	TX Queue#2 packet transmit interrupt 1: Enable the interrupt 0: Disable the interrupt	0
4	R/W	TX_DONE_INT_MSK 1	TX Queue#1 packet transmit interrupt 1: Enable the interrupt 0: Disable the interrupt	0
3	R/W	TX_DONE_INT_MSK 0	TX Queue#0 packet transmit interrupt 1: Enable the interrupt 0: Disable the interrupt	0
2	R/W	RX_DONE_INT_MSK	RX packet receive interrupt 1: Enable the interrupt 0: Disable the interrupt	0
1	R/W	TX_DLY_INT_MSK	Summary of the whole WPDMA TX related interrupts 1: Enable the interrupt 0: Disable the interrupt	0
0	R/W	RX_DLY_INT_MSK	Summary of the whole WPDMA RX related interrupts 1: Enable the interrupt 0: Disable the interrupt	0

WPDMA_GLO_CFG: WPDMA_GLO_CFG Register (offset: 0x0208)

Bits	Type	Name	Description	Initial value
31:16	-	-	Reserved	0
15:8		HDR_SEG_LEN	Specify the header segment size in byte to support RX header/payload scattering function, when set to a non-zero value. When set to zero, the header/payload scattering feature is disabled.	8'b0
7	R/W	BIG_ENDIAN	The endian mode selection. DMA applies the endian rule to convert payload and TX/RX information. DMA won't apply endian rule to register or descriptor. 1: big endian. 0: little endian.	0
6	R/W	TX_WB_DDONE	0:Disable TX_DMA writing back DDONE into TXD 1: Enable TX_DMA writing back DDONE into TXD	1'b1
5:4	R/W	WPDMA_BT_SIZE	Define the burst size of WPDMA 0: 4 DWORD (16bytes) 1: 8 DWORD (32 bytes) 2: 16 DWORD (64 bytes) 3: 32 DWORD (128 bytes)	2'd2
3	RO	RX_DMA_BUSY	1: RX_DMA is busy 0: RX_DMA is not busy	0
2	R/W	RX_DMA_EN	1: Enable RX_DMA 0: Disable RX_DMA (when disabled, RX_DMA will finish the current receiving packet, then stop.)	0
1	RO	TX_DMA_BUSY	1: TX_DMA is busy 0: TX_DMA is not busy	0

0	R/W	TX_DMA_EN	1: Enable TX_DMA 0: Disable TX_DMA (when disabled, TX_DMA will finish the current sending packet, then stop.)	0
---	-----	-----------	--	---

WPDMA_RST_IDX: WPDMA_RST_IDX Register (offset: 0x020C)

Bits	Type	Name	Description	Initial Value
31:17	-	-	Reserved	1'b0
16	W1C	RST_DRX_IDX0	Write 1 to reset to RX_DMARX_IDX0 to 0	1'b0
15:6	-	-	Reserved	1'b0
5	W1C	RST_DTX_IDX3	Write 1 to reset to TX_DMATX_IDX5 to 0	1'b0
4	W1C	RST_DTX_IDX2	Write 1 to reset to TX_DMATX_IDX4 to 0	1'b0
3	W1C	RST_DTX_IDX3	Write 1 to reset to TX_DMATX_IDX3 to 0	1'b0
2	W1C	RST_DTX_IDX2	Write 1 to reset to TX_DMATX_IDX2 to 0	1'b0
1	W1C	RST_DTX_IDX1	Write 1 to reset to TX_DMATX_IDX1 to 0	1'b0
0	W1C	RST_DTX_IDX0	Write 1 to reset to TX_DMATX_IDX0 to 0	1'b0

DELAY_INT_CFG: DELAY_INT_CFG Register (offset: 0x0210)

Bits	Type	Name	Description	Initial Value
31	RW	TXDLY_INT_EN	1: Enable TX delayed interrupt mechanism. 0: Disable TX delayed interrupt mechanism.	1'b0
30:24	RW	TXMAX_PINT	Specified Max # of pended interrupts. When the # of pended interrupts is equal to or greater than the value specified here, or the interrupt pending time reaches the limit (see below), a Final TX_DLY_INT is generated. Set to 0 will disable the pending interrupt count check.	7'b0
23:16	RW	TXMAX_PTIME	Specified Max pending time for the internal TX_DONE_INT0-5. When the pending time equal or greater TXMAX_PTIME x 20us or the # of pended TX_DONE_INT0-5 equal or greater than TXMAX_PINT (see above), an Final TX_DLY_INT is generated Set to 0 will disable pending interrupt time check	8'b0
15	RW	RXDLY_INT_EN	1: Enable RX delayed interrupt mechanism. 0: Disable RX delayed interrupt mechanism.	1'b0
14:8	RW	RXMAX_PINT	Specified Max # of pended interrupts. When the # of pended interrupts equal or greater than the value specified here or interrupt pending time reach the limit (See below), a Final RX_DLY_INT is generated. Set to 0 will disable pending interrupt count check	7'b0
7:0	RW	RXMAX_PTIME	Specified Max pending time for the internal RX_DONE_INT. When the pending time equal or greater RXMAX_PTIME x 20us or , the # of pended RX_DONE_INT equal or greater than RXMAX_PCNT (see above), an Final RX_DLY_INT is generated Set to 0 will disable pending interrupt time check	8'b0

WMM_AIFSN_CFG: WMM_AIFSN_CFG Register (offset: 0x0214)

Bits	Type	Name	Description	Initial Value
31:16	-	-	Reserved	16'b0
15:12	RW	AIFSN3	WMM parameter AIFSN3	4'h0
11:8	RW	AIFSN2	WMM parameter AIFSN2	4'h0
7:4	RW	AIFSN1	WMM parameter AIFSN1	4'h0
3:0	RW	AIFSN0	WMM parameter AIFSN0	4'h0

WMM_CWMIN_CFG: WMM_CWMIN_CFG Register (offset: 0x0218)

Bits	Type	Name	Description	Initial Value
31:16	-	-	Reserved	16'b0

15:12	RW	CW_MIN3	WMM parameter Cw_min3	4'h0
11:8	RW	CW_MIN2	WMM parameter Cw_min2	4'h0
7:4	RW	CW_MIN1	WMM parameter Cw_min1	4'h0
3:0	RW	CW_MIN0	WMM parameter Cw_min0	4'h0

WMM_CWMAX_CFG: WMM_CWMAX_CFG Register (offset: 0x021C)

Bits	Type	Name	Description	Initial Value
31:16	-	-	Reserved	16'b0
15:12	RW	CW_MAX3	WMM parameter Cw_max3	4'h0
11:8	RW	CW_MAX2	WMM parameter Cw_max2	4'h0
7:4	RW	CW_MAX1	WMM parameter Cw_max1	4'h0
3:0	RW	CW_MAX0	WMM parameter Cw_max0	4'h0

WMM_TXOP0_CFG: WMM_TXOP0_CFG Register (offset: 0x0220)

Bits	Type	Name	Description	Initial Value
31:16	RW	TXOP1	WMM parameter TXOP1	16'h0
15:0	RW	TXOP0	WMM parameter TXOP0	16'h0

WMM_TXOP1_CFG: WMM_TXOP1_CFG Register (offset: 0x0224)

Bits	Type	Name	Description	Initial Value
31:16	RW	TXOP3	WMM parameter TXOP3	16'h0
15:0	RW	TXOP2	WMM parameter TXOP2	16'h0

TX_BASE_PTR0: TX_BASE_PTR0 Register (offset: 0x0230)

Bits	Type	Name	Description	Initial Value
31:0	R/W	TX_BASE_PTR0	Point to the base address of TX_Ring0 (4-DWORD aligned address)	0

TX_MAX_CNT0: TX_MAX_CNT0 Register (offset: 0x0234)

Bits	Type	Name	Description	Initial Value
31:12	-	-	Reserved	20'b0
11:0	R/W	TX_MAX_CNT0	The maximum number of TXD count in TXD_Ring0.	0

TX_CTX_IDX0: TX_CTX_IDX0 Register (offset: 0x0238)

Bits	Type	Name	Description	Initial Value
31:12	-	-	Reserved	20'b0
11:0	R/W	TX_CTX_IDX0	Point to the next TXD CPU wants to use	0

TX_DTX_IDX0: TX_DTX_IDX0 Register (offset: 0x023C)

Bits	Type	Name	Description	Initial Value
31:12	-	-	Reserved	20'b0
11:0	RO	TX_DTX_IDX0	Point to the next TXD DMA wants to use	0

TX_BASE_PTR1 (offset:0x0240,default:0x00000000)

TX_MAX_CNT1 (offset:0x0244,default:0x00000000)

TX_CTX_IDX1 (offset:0x0248,default:0x00000000)

TX_DTX_IDX1 (offset:0x024C,default:0x00000000)

TX_BASE_PTR2 (offset:0x0250,default:0x00000000)

TX_MAX_CNT2 (offset:0x0254,default:0x00000000)

TX_CTX_IDX2 (offset:0x0258,default:0x00000000)

TX_DTX_IDX2 (offset:0x025C,default:0x00000000)

TX_BASE_PTR3 (offset:0x0260,default:0x00000000)

TX_MAX_CNT3 (offset:0x0264,default:0x00000000)

TX_CTX_IDX3 (offset:0x0268,default:0x00000000)

TX_DTX_IDX3 (offset:0x026C,default:0x00000000)

TX_BASE_PTR4 (offset:0x0270,default:0x00000000)

TX_MAX_CNT4 (offset:0x0274,default:0x00000000)

TX_CTX_IDX4 (offset:0x0278,default:0x00000000)

TX_DTX_IDX4 (offset:0x027C,default:0x00000000)

TX_BASE_PTR5 (offset:0x0280,default:0x00000000)

TX_MAX_CNT5 (offset:0x0284,default:0x00000000)

TX_CTX_IDX5 (offset:0x0288,default:0x00000000)

TX_DTX_IDX5 (offset:0x028C,default:0x00000000)

RX_BASE_PTR: RX_BASE_PTR Register (offset: 0x0290)

Bits	Type	Name	Description	Initial Value
31:0	R/W	RX_BASE_PTR0	Point to the base address of RXD Ring. It should be a 4-DWORD aligned address	0

RX_MAX_CNT: RX_MAX_CNT Register (offset: 0x0294)

Bits	Type	Name	Description	Initial Value
31:12	-	-	Reserved	0
11:0	R/W	RX_MAX_CNT0	The maximum number of RXD count in RXD Ring #0.	0

RX_CALC_IDX: RX_CALC_IDX Register (offset: 0x0298)

Bits	Type	Name	Description	Initial Value
31:12	-	-	Reserved	0
11:0	R/W	RX_CALC_IDX0	Point to the next RXD CPU wants to allocate to RXD Ring #0.	0

FS_DRX_IDX: FS_DRX_IDX Register (offset: 0x029C)

Bits	Type	Name	Description	Initial Value
31:12	-	-	Reserved	0
11:0	R/W	RX_DRX_IDX0	Point to the next RXD DMA wants to use in FDS Ring#0. It should be a 4-DWORD aligned address.	0

US_CYC_CNT: US_CYC_CNT Register (offset: 0x02A4)

Bits	Type	Name	Description	Initial Value
31:25	-	-	Reserved	0
24	R/W	TEST_EN	Test mode enable	0
23:16	R/W	TEST_SEL	Test mode selection	8'hf0
15:9	-	-	Reserved	0
8	R/W	BT_MODE_EN	Blue-tooth mode enable	0
7:0	RW	US_CYC_CNT	Clock cycle count in 1us. It's dependent on the system clock rate. For system clock rate = 125Mhz, set 8'h7D For system clock rate = 133Mhz, set 8'h85	8'h21

3.20.3.2 Register Description - PBF (base: 1018.0000)

SYS_CTRL: SYS_CTRL Register (offset: 0x0400)

Bits	Type	Name	Description	Initial Value
31:17	-	-	Reserved	0
18	-	-	Reserved	0
16	R/W	HST_PM_SEL	Host program ram write selection.	0
15	-	-	Reserved	
14	R/W	CAP_MODE	Packet buffer capture mode. 0: packet buffer in normal mode. 1: packet buffer in BBP capture mode.	0
13	-	-	Reserved	1
12	R/W	CLKSELECT	MAC/PBF clock source selection. 0: from PLL 1: from 40MHz clock input	0

11	R/W	PBF_CLKEN	PBF clock enable.	0
10	R/W	MAC_CLK_EN	MAC clock enable.	0
9	R/W	DMA_CLK_EN	DMA clock enable.	0
8	-	-	Reserved	0
7	R/W	MCU_READY	MCU ready. 8051 writes '1' to this bit to inform host internal MCU is ready.	0
6:5	-	-	Reserved	0
4	R/W	ASY_RESET	ASYNC interface reset. Write '1' to this bit will put ASYNC into reset state.	0
3	R/W	PBF_RESET	PBF hardware reset. Write '1' to this bit will put PBF into reset state.	0
2	R/W	MAC_RESET	MAC hardware reset. Write '1' to this bit will put MAC into reset state.	0
1	R/W	DMA_RESET	DMA hardware reset. Write '1' to this bit will put DMA into reset state.	0
0	W1C	MCU_RESET	MCU hardware reset. This bit will be auto-cleared after several clock cycles.	0

HOST_CMD: HOST_CMD Register (offset: 0x0404)

Bits	Type	Name	Description	Initial Value
31:0	R/W	HST_CMD	Host command code. Host write this register will trigger interrupt to 8051.	0

PBF_CFG: PBF_CFG Register (offset: 0x0408)

Bits	Type	Name	Description	Initial Value
31:24	-	-	Reserved	0
23:21	R/W	TX1Q_NUM	Queue depth of Tx1Q. The maximum number is 7.	3'h7
20:16	R/W	TX2Q_NUM	Queue depth of Tx2Q. The maximum number is 20.	5'h14
15	R/W	NULL0_MODE	HCCA NULL0 frame auto mode. In this mode, NULL0 frame will be automatically transmitted if TXQ1 is enabled but empty. After NULL0 frame transmitted, TXQ1 will be disabled. 0: disable 1: enable	0
14	R/W	NULL1_MODE	HCCA NULL1 frame auto mode. In this mode, all TXQ (0/1/2) will be disabled after NULL1 frame transmitted. 0: disable 1: enable	0
13	R/W	RX_DROP_MODE	Rx drop mode. When set, PBF will drop Rx packet before into DMA. 0: normal mode 1: drop mode	0
12	R/W	TX0Q_MODE	Tx0Q operation mode. 0: auto mode 1: manual mode	0
11	R/W	TX1Q_MODE	Tx1Q operation mode. 0: auto mode 1: manual mode	0
10	R/W	TX2Q_MODE	Tx2Q operation mode. 0: auto mode 1: manual mode	0
9	R/W	RX0Q_MODE	Rx0Q operation mode. 0: auto mode 1: manual mode	0
8	R/W	HCCA_MODE	HCCA auto mode. In this mode, TXQ1 will be enabled when	0

			CF-POLL arriving. 0: disable 1: enable	
7:5	-	-	Reserved	0
4	R/W	TX0Q_EN	Tx0Q enable 0: disable 1: enable	1
3	R/W	TX1Q_EN	Tx1Q enable 0: disable 1: enable	0
2	R/W	TX2Q_EN	Tx2Q enable 0: disable 1: enable	1
1	R/W	RX0Q_EN	Rx0Q enable 0: disable 1: enable	1
0	-	-	Reserved	0

MAX_PCNT: MAX_PCNT Register (offset: 0x040C)

Bits	Type	Name	Description	Initial Value
31:24	R/W	MAX_TX0Q_PCNT	Maximum buffer page count of Tx0Q.	8'h1f
23:16	R/W	MAX_TX1Q_PCNT	Maximum buffer page count of Tx1Q.	8'h3f
15:8	R/W	MAX_TX2Q_PCNT	Maximum buffer page count of Tx2Q.	8'h9f
7:0	R/W	MAX_RX0Q_PCNT	Maximum buffer page count of Rx0Q.	8'h9f

BUF_CTRL: BUF_CTRL Register (offset: 0x0410)

Bits	Type	Name	Description	Initial Value
31:12	-	-	Reserved	0
11	W1C	WRITE_TX0Q	Manual write Tx0Q.	0
10	W1C	WRITE_TX1Q	Manual write Tx1Q.	0
9	W1C	WRITE_TX2Q	Manual write Tx2Q	0
8	W1C	WRITE_RX0Q	Manual write Rx0Q	0
7	W1C	NULL0_KICK	Kick out NULL0 frame. This bit will be cleared after NULL0 frame is transmitted.	0
6	W1C	NULL1_KICK	Kick out NULL1 frame. This bit will be cleared after NULL1 frame is transmitted.	0
5	W1C	BUF_RESET	Buffer reset.	0
4	-	-	Reserved	0
3	W1C	READ_TX0Q	Manual read Tx0Q.	0
2	W1C	READ_TX1Q	Manual read Tx1Q.	0
1	W1C	READ_TX2Q	Manual read Tx2Q	0
0	W1C	READ_RX0Q	Manual read Rx0Q	0

MCU_INT_STA: MCU_INT_STA Register (offset:0x0414)

Bits	Type	Name	Description	Initial Value
31:28	-	-	Reserved	0
27	R/W	MAC_INT_11	MAC interrupt 11: Reserved	0
26	R/W	MAC_INT_10	MAC interrupt 10: Reserved	0
25	R/W	MAC_INT_9	MAC interrupt 9: Reserved	0
24	R/W	MAC_INT_8	MAC interrupt 8: RX QoS CF-Poll interrupt	0
23	R/W	MAC_INT_7	MAC interrupt 7: TXOP early termination interrupt	0
22	R/W	MAC_INT_6	MAC interrupt 6: TXOP early timeout interrupt	0
21	R/W	MAC_INT_5	MAC interrupt 5: Reserved	0

20	R/W	MAC_INT_4	MAC interrupt 4: GP timer interrupt	0
19	R/W	MAC_INT_3	MAC interrupt 3: Auto wakeup interrupt	0
18	R/W	MAC_INT_2	MAC interrupt 2: TX status interrupt	0
17	R/W	MAC_INT_1	MAC interrupt 1: Pre-TBTT interrupt	0
16	R/W	MAC_INT_0	MAC interrupt 0: TBTT interrupt	0
15:12	-	-	Reserved	0
11	R/W	DTX0_INT	DMA to TX0Q frame transfer complete interrupt.	0
10	R/W	DTX1_INT	DMA to TX1Q frame transfer complete interrupt.	0
9	R/W	DTX2_INT	DMA to TX2Q frame transfer complete interrupt.	0
8	R/W	DRX0_INT	RX0Q to DMA frame transfer complete interrupt.	0
7	R/W	HCMD_INT	Host command interrupt.	0
6	R/W	NOTX_INT	NULL0 frame Tx complete interrupt.	0
5	R/W	N1TX_INT	NULL1 frame Tx complete interrupt.	0
4	R/W	BCNTX_INT	Beacon frame Tx complete interrupt.	0
3	R/W	MTX0_INT	TX0Q to MAC frame transfer complete interrupt.	0
2	R/W	MTX1_INT	TX1Q to MAC frame transfer complete interrupt.	0
1	R/W	MTX2_INT	TX2Q to MAC frame transfer complete interrupt.	0
0	R/W	MRX0_INT	MAC to RX0Q frame transfer complete interrupt.	0

*This register is only for 8051.

MCU_INT_ENA: MCU_INT_ENA Register (offset: 0x0418)

Bits	Type	Name	Description	Initial Value
31:28	-	-	Reserved	0
27	R/W	MAC_INT11_EN	MAC interrupt 11 enable	0
26	R/W	MAC_INT10_EN	MAC interrupt 10 enable	0
25	R/W	MAC_INT9_EN	MAC interrupt 9 enable	0
24	R/W	MAC_INT8_EN	MAC interrupt 8 enable	0
23	R/W	MAC_INT7_EN	MAC interrupt 7 enable	0
22	R/W	MAC_INT6_EN	MAC interrupt 6 enable	0
21	R/W	MAC_INT5_EN	MAC interrupt 5 enable	0
20	R/W	MAC_INT4_EN	MAC interrupt 4 enable	0
19	R/W	MAC_INT3_EN	MAC interrupt 3 enable	0
18	R/W	MAC_INT2_EN	MAC interrupt 2 enable	0
17	R/W	MAC_INT1_EN	MAC interrupt 1 enable	0
16	R/W	MAC_INT0_EN	MAC interrupt 0 enable	0
15:12	-	-	Reserved	0
11	R/W	DTX0_INT_EN	DMA to TX0Q frame transfer complete interrupt enable.	0
10	R/W	DTX1_INT_EN	DMA to TX1Q frame transfer complete interrupt enable.	0
9	R/W	DTX2_INT_EN	DMA to TX2Q frame transfer complete interrupt enable.	0
8	R/W	DRX0_INT_EN	RX0Q to DMA frame transfer complete interrupt enable.	0
7	R/W	HCMD_INT_EN	Host command interrupt enable.	0
6	R/W	NOTX_INT_EN	NULL0 frame Tx complete interrupt enable.	0
5	R/W	N1TX_INT_EN	NULL1 frame Tx complete interrupt enable.	0
4	R/W	BCNTX_INT_EN	Beacon frame Tx complete interrupt enable.	0
3	R/W	MTX0_INT_EN	TX0Q to MAC frame transfer complete interrupt enable.	0
2	R/W	MTX1_INT_EN	TX1Q to MAC frame transfer complete interrupt enable.	0
1	R/W	MTX2_INT_EN	TX2Q to MAC frame transfer complete interrupt enable.	0
0	R/W	MRX0_INT_EN	MAC to RX0Q frame transfer complete interrupt enable.	0

*This register is only for 8051.

TX0Q_IO: TX0Q_IO Register (offset: 0x041C)

Bits	Type	Name	Description	Initial Value
31:16	-	-	Reserved	0
15:0	R/W	TX0Q_IO	TX0Q IO port. This register is used in manual mode.	0

TX1Q_IO: TX1Q_IO Register (offset: 0x0420)

Bits	Type	Name	Description	Initial Value
31:16	-	-	Reserved	0
15:0	R/W	TX1Q_IO	TX1Q IO port. This register is used in manual mode.	0

TX2Q_IO: TX2Q_IO Register (offset: 0x0424)

Bits	Type	Name	Description	Initial Value
31:16	-	-	Reserved	0
15:0	R/W	TX2Q_IO	TX2Q IO port. This register is used in manual mode.	0

RX0Q_IO: RX0Q_IO Register (offset: 0x0428)

Bits	Type	Name	Description	Initial Value
31:16	-	-	Reserved	0
15:0	R/W	RX0Q_IO	RX0Q IO port. This register is used in manual mode.	0

BCN_OFFSET0: BCN_OFFSET0 Register (offset: 0x042C)

Bits	Type	Name	Description	Initial Value
31:24	R/W	BCN3_OFFSET	Beacon #3 address offset in shared memory. Unit is 64 byte.	8'hec
23:16	R/W	BCN2_OFFSET	Beacon #2 address offset in shared memory. Unit is 64 byte.	8'he8
15:8	R/W	BCN1_OFFSET	Beacon #1 address offset in shared memory. Unit is 64 byte.	8'he4
7:0	R/W	BCN0_OFFSET	Beacon #0 address offset in shared memory. Unit is 64 byte.	8'he0

BCN_OFFSET1: BCN_OFFSET1 Register (offset: 0x0430)

Bits	Type	Name	Description	Initial Value
31:24	R/W	BCN7_OFFSET	Beacon #7 address offset in shared memory. Unit is 64 byte.	8'hfc
23:16	R/W	BCN6_OFFSET	Beacon #6 address offset in shared memory. Unit is 64 byte.	8'hf8
15:8	R/W	BCN5_OFFSET	Beacon #5 address offset in shared memory. Unit is 64 byte.	8'hf4
7:0	R/W	BCN4_OFFSET	Beacon #4 address offset in shared memory. Unit is 64 byte.	8'hf0

TXRXQ_STA: TXRXQ_STA Register (offset: 0x0434)

Bits	Type	Name	Description	Initial Value
31:24	RO	RX0Q_STA	RxQ status	8'h22
23:16	RO	TX2Q_STA	Tx2Q status	8'h02
15:8	RO	TX1Q_STA	Tx1Q status	8'h02
7:0	RO	TX0Q_STA	Tx0Q status	8'h02

TXRXQ_PCNT: TXRXQ_PCNT Register (offset: 0x0438)

Bits	Type	Name	Description	Initial Value
31:24	RO	RX0Q_PCNT	Page count in RxQ	8'h00
23:16	RO	TX2Q_PCNT	Page count in Tx2Q	8'h00
15:8	RO	TX1Q_PCNT	Page count in Tx1Q	8'h00
7:0	RO	TX0Q_PCNT	Page count in Tx0Q	8'h00

PBF_DBG: PBF_DBG Register (offset: 0x043C)

Bits	Type	Name	Description	Initial Value
31:8	-	-	Reserved	0
7:0	RO	FREE_PCNT	Free page count	8'hFE

CAP_CTRL: CAP_CTRL Register (offset: 0x0440)

Bits	Type	Name	Description	Initial Value
31	R/W	CAP_ADC_FEQ	Data source. 0: data from the ADC output 1: Data from the FEQ output	0
30	WC	CAP_START	Data capture start 0: No action	0

			1: Start data capture (cleared automatically after capture finished)	
29	W1C	MAN_TRIG	Manual capture trigger	0
28:16	R/W	TRIG_OFFSET	Starting address offset before trigger point.	13'h140
15:13	-	-	Reserved	0
12:0	RO	START_ADDR	Starting address of captured data.	13'h000

3.20.3.3 Register Description – RF CFG (base: 1018.0000)

RF_CSR_CFG: RF_CSR_CFG Register (offset: 0x0500)

Bits	Type	Name	Description	Init Value
31:18	R	-	Reserved	0
17	R/W1	RF_CSR_KICK	Write – kick RF register read/write 0: do nothing 1: kick read/write process Read – Polling RF register read/write 0: idle 1: busy	0
16	R/W	RF_CSR_WR	0: read 1: write	0
15:13	R	-	Reserved	0
12:8	R/W	TESTCSR_RFACC_REGNUM	RF register ID 0 for R0, 1 for R1 and so on.	0
7:0	R/W	RF_CSR_DATA	Write – DATA written to RF Read – DATA read from RF	0

RF_SETTING: RF_SETTING Register (offset: 0x0504)

Bits	Type	Name	Description	Init Value
31:26	R	-	Reserved	0
25	R/W	TEST_RF_PA_PE_G1	RF_PA_PE_G0 value for Rx path 1 in test mode	0
24	R/W	TEST_RF_DC_CAL_EN1	RF_DC_CAL_EN value for Rx path 1 in test mode	0
23	R	-	Reserved	
22:21	R/W	TEST_RF_LNA1	RF_LNA value for Rx path 1 in test mode	0
20:16	R/W	TEST_RF_VGA1	RF VGA value for Rx path 1 in test mode	0
15:13	R	-	Reserved	
12	R/W	TESTCSR_RF_PE	RF_PE value in test mode	0
11	R/W	TESTCSR_RF_TR	RF_TR value in test mode	0
10	R/W	TEST_RF_LDO123_PE	LDO123_PE value in test mode	0
9	R/W	TEST_RF_PA_PE_G0	RF_PA_PE_G0 value for Rx path 0 in test mode	0
8	R/W	TEST_RF_DC_CAL_EN0	RF_DC_CAL_EN value for Rx path 0 in test mode	0
7	R	-	Reserved	
6:5	R/W	TEST_RF_LNA0	RF_LNA value for Rx path 0 in test mode	0
4:0	R/W	TEST_RF_VGA0	RF VGA value for Rx path 0 in test mode	0

RF_TEST_CONTROL: RF_TEST_CONTROL Register (offset: 0x0508)

Bits	Type	Name	Description	Init Value
31:1	R	-	Reserved	0
0	R/W	BYPASS_RF	When set, RF control signals come from RF_SETTING instead of MAC/BBP in normal operation mode	0

3.20.3.4 Register Description - MAC (base: 1018.0000)

ASIC_VER_ID: ASIC_VER_ID Register (offset: 0x1000)

Bits	Type	Name	Description	Initial value
31:16	R	VER_ID	ASIC version ID	16'h2860
15:0	R	REV_ID	ASIC reversion ID	16'h0101

MAC_SYS_CTRL: MAC_SYS_CTRL Register (offset: 0x1004)

Bits	Type	Name	Description	Initial value
31:8	-	-	Reserved	0
7	R/W	RX_TS_EN	Write 32-bit hardware RX timestamp instead of (RXWI->RSSI), and write (RXWI->RSSI) instead of (RXWI->SNR). Note: For QA RX sniffer mode only. 1: enable 0: disable	0
6	R/W	WLAN_HALT_EN	Enable external WLAN halt control signal 1: enable 0: disable	0
5	R/W	PBF_LOOP_EN	Packet buffer loop back enable (TX->RX) 1: enable 0: disable	0
4	R/W	CONT_TX_TEST	Continuous TX production test; override MAC_RX_EN, MAC_TX_EN 1: enable 0: disable	0
3	R/W	MAC_RX_EN	MAC RX enable 1: enable 0: disable	0
2	R/W	MAC_TX_EN	MAC TX enable 1: enable 0: disable	0
1	R/W	BBP_HRST	BBP hard-reset 1: BBP in reset state 0: BBP in normal state Note: Whole BBP including BBP registers will be reset.	1
0	R/W	MAC_SRST	MAC soft-reset 1: MAC in reset state 0: MAC in normal state Note: MAC registers and tables will NOT be reset.	1

Note: MAC hard-reset is outside the scope of MAC registers.

MAC_ADDR_DW0: MAC_ADDR_DW0 Register (offset: 0x1008)

Bits	Type	Name	Description	Initial value
31:24	R/W	MAC_ADDR_3	MAC address byte3	0
23:16	R/W	MAC_ADDR_2	MAC address byte2	0
15:8	R/W	MAC_ADDR_1	MAC address byte1	0
7:0	R/W	MAC_ADDR_0	MAC address byte0	0

MAC_ADDR_DW1: MAC_ADDR_DW1 Register (offset: 0x100C)

Bits	Type	Name	Description	Initial value
31:16	-	-	Reserved	0
15:8	R/W	MAC_ADDR_5	MAC address byte5	0
7:0	R/W	MAC_ADDR_4	MAC address byte4	0

Note: Byte0 is the first byte on network. Its LSB bit is the first bit on network. For a MAC address captured on the network with order 00:01:02:03:04:05, byte0=00, byte1=01 etc.

MAC_BSSID_DW0: MAC_BSSID_DW0 Register (offset: 0x1010)

Bits	Type	Name	Description	Initial value
31:24	R/W	BSSID_3	BSSID byte3	0
23:16	R/W	BSSID_2	BSSID byte2	0
15:8	R/W	BSSID_1	BSSID byte1	0
7:0	R/W	BSSID_0	BSSID byte0	0

MAC_BSSID_DW1: MAC_BSSID_DW1 Register (offset: 0x1014)

Bits	Type	Name	Description	Initial value
31:21	-	-	Reserved	0
20:18	R/W	MULTI_BCN_NUM	Multiple BSSID Beacon number 0: one back-off beacon 1-7: SIFS-burst beacon count	0
17:16	R/W	MULTI_BSSID_MODE	Multiple BSSID mode In multiple-BSSID AP mode, BSSID shall be the same as MAC_ADDR, that is, this device owns multiple MAC_ADDR in this mode. The multiple MAC_ADDR/BSSID are distinguished by [bit2: bit0] of byte5. 0: 1-BSSID mode (BSS index = 0) 1: 2-BSSID mode (byte5.bit0 as BSS index) 2: 4-BSSID mode (byte5.bit1:0 as BSS index) 3: 8-BSSID mode (byte5.bit2:0 as BSS index)	0
15:8	R/W	BSSID_5	BSSID byte5	0
7:0	R/W	BSSID_4	BSSID byte4	0

MAX_LEN_CFG: MAX_LEN_CFG Register (offset: 0x1018)

Bits	Type	Name	Description	Initial value
31:20	-	-	Reserved	0
19:16	R/W	MIN_MPDU_LEN	Minimum MPDU length (unit: bytes) MAC will drop the MPDU if the length is less than this limitation. Applied only in MAC RX.	10
15:14	-	-	Reserved	0
13:12	R/W	MAX_PSDU_LEN	Maximum PSDU length (power factor) 0: 2 ¹³ = 8K bytes 1: 2 ¹⁴ = 16K bytes 2: 2 ¹⁵ = 32K bytes 3: 2 ¹⁶ = 64K bytes MAC will NOT generate A-MPDU with length greater than this limitation. Applied only in MAC TX.	0
11:0	R/W	MAX_MPDU_LEN	Maximum MPDU length (unit: bytes) MAC will drop the MPDU if the length is greater than this limitation. Applied only in MAC RX.	4095

BBP_CSR_CFG: BBP_CSR_CFG Register (offset: 0x101C)

Bits	Type	Name	Description	Initial value
31:20	-	-	Reserved	0
19	R/W	BBP_RW_MODE	BBP Register R/W mode	1

			1: parallel mode 0: serial mode	
18	R/W	BBP_PAR_DUR	BBP Register parallel R/W pulse width 0: pulse width = 62.5ns 1: pulse width = 112.5ns Note: Please set BBP_PAR_DUR=1 in 802.11J mode.	0
17	R/W	BBP_CSR_KICK	Write - kick BBP register read/write 0: do nothing 1: kick read/write process Read - Polling BBP register read/write progress 0: idle, 1: busy	0
16	R/W	BBP_CSR_RW	0: Write 1: Read	0
15:8	R/W	BBP_ADDR	BBP register ID 0 for R0, 1 for R1, and so on.	0
7:0	R/W	BBP_DATA	Write - Data written to BBP Read - Data read from BBP	0

RF_CSR_CFG0: RF_CSR_CFG0 Register (offset: 0x1020)

Bits	Type	Name	Description	Initial value
31	R/W	RF_REG_CTRL	Write: 1 - RF_REG0/1/2 to RF chip Read: 0 - idle, 1 - busy	0
30	R/W	RF_LE_SEL	RF_LE selection 0: RF_LE0 activate 1: RF_LE1 activate	0
29	R/W	RF_LE_STBY	RF_LE standby mode 0: RF_LE is high when standby 1: RF_LE is low when standby	0
28:24	R/W	RF_REG_WIDTH	RF register bit width Default: 22	22
23:0	R/W	RF_REG_0	RF register0 ID and content	0

RF_CSR_CFG1: RF_CSR_CFG1 Register (offset: 0x1024)

Bits	Type	Name	Description	Initial value
31:25	-	-	Reserved	0
24	R/W	RF_DUR	Gap between BB_CONTROL_RF and RF_LE 0: 3 system clock cycle (37.5μsec) 1: 5 system clock cycle (62.5μsec)	0
23:0	R/W	RF_REG_1	RF register1 ID and content	0

RF_CSR_CFG2: RF_CSR_CFG2 Register (offset: 0x1028)

Bits	Type	Name	Description	Initial value
31:24	-	-	Reserved	0
23:0	R/W	RF_REG_2	RF register2 ID and content	0

Note: Software should make sure the first bit (MSB in the specified bit number) written to RF is 0 for RF chip mode selection)

LED_CFG: LED_CFG Register (offset: 0x102C)

Bits	Type	Name	Description	Initial value
31	-	-	Reserved	0
30	R/W	LED_POL	LED polarity	0

			0: active low 1: active high	
29:28	R/W	Y_LED_MODE	Yellow LED mode 0: off 1: blinking upon TX 2: periodic slow blinking 3: always on	0
27:26	R/W	G_LED_MODE	Green LED mode 0: off 1: blinking upon TX 2: periodic slow blinking 3: always on	2
25:24	R/W	R_LED_MODE	Red LED mode 0: off 1: blinking upon TX 2: periodic slow blinking 3: always on	1
23:22	-	-	Reserved	0
21:16	R/W	SLOW_BLK_TIME	Slow blinking period (unit: 1sec)	3
15:8	R/W	LED_OFF_TIME	TX blinking off period (unit: 1ms)	30
7:0	R/W	LED_ON_TIME	TX blinking on period (unit: 1ms)	70

AMPDU_MAX_LEN_20M1S: AMPDU_MAX_LEN_20M1S Register (offset: 0x1030)

Bits	Type	Name	Description	Initial value
31:28	R/W	AMPDU_MAX_BW20_MCS7	Maximum AMPDU for BW20 MCS7*	7
27:24	R/W	AMPDU_MAX_BW20_MCS6	Maximum AMPDU for BW20 MCS6*	7
23:20	R/W	AMPDU_MAX_BW20_MCS5	Maximum AMPDU for BW20 MCS5*	7
19:16	R/W	AMPDU_MAX_BW20_MCS4	Maximum AMPDU for BW20 MCS4*	7
15:12	R/W	AMPDU_MAX_BW20_MCS3	Maximum AMPDU for BW20 MCS3*	7
11:08	R/W	AMPDU_MAX_BW20_MCS2	Maximum AMPDU for BW20 MCS2*	7
07:04	R/W	AMPDU_MAX_BW20_MCS1	Maximum AMPDU for BW20 MCS1*	7
03:00	R/W	AMPDU_MAX_BW20_MCS0	Maximum AMPDU for BW20 MCS0*	7

Note1*: 0-2: 2K bytes, 3: 4K bytes, 4: 8K, 5: 16K, 6: 32K, 7: 64K

Note2: The value applied together with 0x1018 MAX_PSDU_LEN.

AMPDU_MAX_LEN_20M2S: AMPDU_MAX_LEN_20M2S Register (offset: 0x1034)

Bits	Type	Name	Description	Initial value
31:28	R/W	AMPDU_MAX_BW20_MCS15	Maximum AMPDU for BW20 MCS15*	7
27:24	R/W	AMPDU_MAX_BW20_MCS14	Maximum AMPDU for BW20 MCS14*	7
23:20	R/W	AMPDU_MAX_BW20_MCS13	Maximum AMPDU for BW20 MCS13*	7
19:16	R/W	AMPDU_MAX_BW20_MCS12	Maximum AMPDU for BW20 MCS12*	7
15:12	R/W	AMPDU_MAX_BW20_MCS11	Maximum AMPDU for BW20 MCS11*	7
11:08	R/W	AMPDU_MAX_BW20_MCS10	Maximum AMPDU for BW20 MCS10*	7
07:04	R/W	AMPDU_MAX_BW20_MCS9	Maximum AMPDU for BW20 MCS9*	7
03:00	R/W	AMPDU_MAX_BW20_MCS8	Maximum AMPDU for BW20 MCS8*	7

Note1*: 0-2: 2K bytes, 3: 4K bytes, 4: 8K, 5: 16K, 6: 32K, 7: 64K

Note2: The value applied together with 0x1018 MAX_PSDU_LEN.

AMPDU_MAX_LEN_40M1S: AMPDU_MAX_LEN_40M1S Register (offset: 0x1038)

Bits	Type	Name	Description	Initial value
31:28	R/W	AMPDU_MAX_BW40_MCS7	Maximum AMPDU for BW40 MCS7*	7
27:24	R/W	AMPDU_MAX_BW40_MCS6	Maximum AMPDU for BW40 MCS6*	7
23:20	R/W	AMPDU_MAX_BW40_MCS5	Maximum AMPDU for BW40 MCS5*	7
19:16	R/W	AMPDU_MAX_BW40_MCS4	Maximum AMPDU for BW40 MCS4*	7
15:12	R/W	AMPDU_MAX_BW40_MCS3	Maximum AMPDU for BW40 MCS3*	7
11:08	R/W	AMPDU_MAX_BW40_MCS2	Maximum AMPDU for BW40 MCS2*	7
07:04	R/W	AMPDU_MAX_BW40_MCS1	Maximum AMPDU for BW40 MCS1*	7
03:00	R/W	AMPDU_MAX_BW40_MCS0	Maximum AMPDU for BW40 MCS0*	7

Note1*: 0-2: 2K bytes, 3: 4K bytes, 4: 8K, 5: 16K, 6: 32K, 7: 64K

Note2: The value applied together with 0x1018 MAX_PSDU_LEN.

AMPDU_MAX_LEN_40M2S: AMPDU_MAX_LEN_40M2S Register (offset: 0x103C)

Bits	Type	Name	Description	Initial value
31:28	R/W	AMPDU_MAX_BW40_MCS15	Maximum AMPDU for BW40 MCS15*	7
27:24	R/W	AMPDU_MAX_BW40_MCS14	Maximum AMPDU for BW40 MCS14*	7
23:20	R/W	AMPDU_MAX_BW40_MCS13	Maximum AMPDU for BW40 MCS13*	7
19:16	R/W	AMPDU_MAX_BW40_MCS12	Maximum AMPDU for BW40 MCS12*	7
15:12	R/W	AMPDU_MAX_BW40_MCS11	Maximum AMPDU for BW40 MCS11*	7
11:08	R/W	AMPDU_MAX_BW40_MCS10	Maximum AMPDU for BW40 MCS10*	7
07:04	R/W	AMPDU_MAX_BW40_MCS9	Maximum AMPDU for BW40 MCS9*	7
03:00	R/W	AMPDU_MAX_BW40_MCS8	Maximum AMPDU for BW40 MCS8*	7

Note1*: 0-2: 2K bytes, 3: 4K bytes, 4: 8K, 5: 16K, 6: 32K, 7: 64K

Note2: The value applied together with 0x1018 MAX_PSDU_LEN.

AMPDU_BA_WINSIZE: AMPDU_BA_WINSIZE Register ((offset: 0x1040)

Bits	Type	Name	Description	Initial value
31:07	R	-	Reserved	0
--:06	R/W	FORCE_BA_WINSIZE_EN	Enable forced BA window size over BA window size value in TXWI 0: disable, 1: enable	0
05:00	R/W	FORCE_BA_WINSIZE	Forced BA window size	0

XIFS_TIME_CFG: XIFS_TIME_CFG Register (offset:0x1100)

Bits	Type	Name	Description	Initial value
31:30	-	-	Reserved	
29	R/W	BB_RXEND_EN	BB_RX_END signal enable Refer BB_RX_END signal from BBP RX logic to start SIFS defer. 0: disable 1: enable	1
28:20	R/W	EIFS_TIME	EIFS time (unit: 1us) EIFS is the defer time after reception of a CRC error packet. After deferring EIFS, the normal back-off process may proceed.	314
19:16	R/W	OFDM_XIFS_TIME	Delayed OFDM SIFS time compensator (unit: 1us) When BB_RX_END from BBP is a delayed version the SIFS deferred will be (OFDM_SIFS_TIME - OFDM_XIFS_TIME)	4
15:8	R/W	OFDM_SIFS_TIME	OFDM SIFS time (unit: 1us) Applied after OFDM TX/RX.	16
7:0	R/W	CCK_SIFS_TIME	CCK SIFS time (unit: 1us) Applied after CCK TX/RX.	10

Note1: EIFS = SIFS + ACK @ 1Mbps + DIFS = 10us (SIFS) + 192us (long preamble) + 14*8us (ACK) + 50us (DIFS) = 364. However, MAC should start back-off procedure after (EIFS-DIFS).

Note2: EIFS is not applied if MAC is a TXOP initiator that owns the channel.

Note3: EIFS is not started if AMPDU is only partial corrupted.

Caution: It is recommended that both (CCK_SIFS_TIME) and (OFDM_SIFS_TIME) are no less than TX/RX transition time. If the SIFS value is not long enough, a SIFS burst transmission may be replaced with a PIFS burst one.

BKOFF_SLOT_CFG: BKOFF_SLOT_CFG Register (offset: 0x1104)

Bits	Type	Name	Description	Initial value
31:12	-	-	Reserved	0
11:8	R/W	CC_DELAY_TIME	Channel clear delay (unit: 1-us) This value specified the TX guard time after channel is clear.	2
7:0	R/W	SLOT_TIME	Slot time (unit: 1-us) This value specified the slot boundary after deferring SIFS time. Note: Default 20us is for 11b/g. 11a and 11g-short-slot-mode is 9us.	20

NAV_TIME_CFG: NAV_TIME_CFG Register (offset: 0x1108)

Bits	Type	Name	Description	Initial value
31	WC	NAV_UPD	NAV timer manual update command 0: Do nothing 1: Update NAV timer with NAV_UPD_VAL	0
30:16	R/W	NAV_UPD_VAL	NAV timer manual update value (unit: 1us)	0
15	R/W	NAV_CLR_EN	NAV timer auto-clear enable When enabled, MAC will auto clear NAV timer after the reception of CF-End frame from previous NAV holder STA. 0: disable 1: enable	1
14:0	R	NAV_TIMER	NAV timer (unit: 1us) The timer is set by other STA and will auto countdown to zero. The STA who set the NAV timer is called the NAV holder. When NAV timer is nonzero, MAC will not send any packet.	0

CH_TIME_CFG: CH_TIME_CFG Register (offset: 0x110C)

Bits	Type	Name	Description	Initial value
31:5	-	-	Reserved	0
4	R/W	EIFS_AS_CH_BUSY	Count EIFS as channel busy 0: disable 1: enable	1
3	R/W	NAV_AS_CH_BUSY	Count NAV as channel busy 0: disable 1: enable	1
2	R/W	RX_AS_CH_BUSY	Count RX busy as channel busy 0: disable 1: enable	1
1	R/W	TX_AS_CH_BUSY	Count TX busy as channel busy 0: disable 1: enable	1
0	R/W	CH_STA_TIMER_EN	Channel statistic timer enable 0: disable 1: enable	0

PBF_LIFE_TIMER: PBF_LIFE_TIMER Register (offset: 0x1110)

Bits	Type	Name	Description	Initial value
31:0	R	PBF_LIFE_TIMER	TX/RX MPDU timestamp timer (free run) Unit: 1us	0

BCN_TIME_CFG: BCN_TIME_CFG Register (offset: 0x1114)

Bits	Type	Name	Description	Initial value
31:24	R/W	TSF_INS_COMP	TSF insertion compensation value (unit: 1us) When inserting TSF, add this value with local TSF timer as the TX timestamp.	0
23:21	-	-	Reserved	0
20	R/W	BCN_TX_EN	BEACON frame TX enable When enabled, MAC sends BEACON frame at TBTT interrupt. 0: disable 1: enable	0
19	R/W	TBTT_TIMER_EN	TBTT timer enable When enabled, TBTT interrupt will be issued periodically with period specified in (BCN_INTVAL). 0: disable 1: enable	0
18:17	R/W	TSF_SYNC_MODE	Local 64-bit TSF timer synchronization mode 00: disable 01: (STA infra-structure mode) Upon the reception of BEACON frame from associated BSS, local TSF is always updated with remote TSF. 10: (STA ad-hoc mode) Upon the reception of BEACON frame from associated BSS, local TSF is updated with remote TSF only if the remote TSF is greater than local TSF. 11: (AP mode) SYNC with nobody	0
16	R/W	TSF_TIMER_EN	Local 64-bit TSF timer enable When enabled, TSF timer will re-start from zero. 0: disable 1: enable	0
15:0	R/W	BCN_INTVAL	BEACON interval (unit: 64us) This value specified the interval between Maximum beacon interval is about 4sec.	1600

TBTT_SYNC_CFG: TBTT_SYNC_CFG Register (offset: 0x1118)

Bits	Type	Name	Description	Initial value
31:24	-	-	Reserved	0
23:20	R/W	BCN_CWMIN	Beacon transmission CWMIN after TBTT interrupt (unit: slot)	4
19:16	R/W	BCN_AIFSN	Beacon transmission AIFSN after TBTT interrupt (unit: slot)	2
15:8	R/W	BCN_EXP_WIN	Beacon expecting window duration (unit: 64us) The window starts from TBTT interrupt. The phase of "TBTT interrupt train" will NOT be adjusted by the beacon arrived within the window.	32
7:0	R/W	TBTT_ADJUST	IBSS mode TBTT phase adaptive adjustment step (unit: 1us), default value is 16us. In IBSS mode (Ad hoc), if consecutive TX beacon failures (or consecutive success) happened, TBTT timer will adjust it phase to meet the external Ad hoc TBTT time.	16

TSF_TIMER_DW0: TSF_TIMER_DW0 Register (offset: 0x111C)

Bits	Type	Name	Description	Initial value
31:0	R	TSF_TIMER_DW0	Local TSF timer LSB 32 bits (unit: 1us)	0

TSF_TIMER_DW1: TSF_TIMER_DW1 Register (offset: 0x1120)

Bits	Type	Name	Description	Initial value
31:0	R	TSF_TIMER_DW1	Local TSF timer MSB 32 bits (unit: 1us)	0

TBTT_TIMER: TBTT_TIMER_DW0 Register (offset: 0x1124)

Bits	Type	Name	Description	Initial value
31:17	-	-	Reserved	0
16:0	R	TBTT_TIMER	TBTT Timer (unit: 32us) The time remains till next TBTT. When TBTT_TIMER_EN is enabled, the timer will down count from BCN_INTVAL to zero. When TBTT_TIMER_EN is disabled, the timer will stay in zero.	0

INT_TIMER_CFG: INT_TIMER_CFG Register (offset: 0x1128)

Bits	Type	Name	Description	Initial value
31:16	R/W	GP_TIMER	Period of general purpose interrupt timer (Unit: 64us)	0
15:0	R/W	PRE_TBTT_TIMER	Pre-TBTT interrupt time (unit: 64us) The value specified the interrupt timing before TBTT interrupt.	0

INT_TIMER_EN: INT_TIMER_EN Register (offset: 0x112C)

Bits	Type	Name	Description	Initial value
31:2	-	-	Reserved	0
1	R/W	GP_TIMER_EN	Periodic general purpose interrupt timer enable 0: disable 1: enable	0
0	R/W	PRE_TBTT_INT_EN	Pre-TBTT interrupt enable 0: disable 1: enable	0

CH_IDLE_STA: CH_IDLE_STA Register (offset: 0x1130)

Bits	Type	Name	Description	Initial value
31:0	RC	CH_IDLE_TIME	Channel idle time Unit: 1us	0

In application, the channel busy time can be derived by the equation:

$$CH_BUSY_TIME = \text{host polling period} - CH_IDLE_TIME.$$

Reserved: Reserved Register (offset: 0x1134)

Bits	Type	Name	Description	Initial value
31:0	RC	Reserved	Reserved	0

MAC_STATUS_REG: MAC_STATUS_REG Register (offset: 0x1200)

Bits	Type	Name	Description	Initial value
31:2	-	-	Reserved	0
1	R	RX_STATUS	RX status 0: Idle 1: Busy	0
0	R	TX_STATUS	TX status 0: Idle 1: Busy	0

PWR_PIN_CFG: PWR_PIN_CFG Register (offset: 0x1204)

Bits	Type	Name	Description	Initial value
31:4	-	-	Reserved	0

3	R/W	IO_ADDA_PD	AD/DA power down	0
2	R/W	IO_PLL_PD	PLL power down	0
1	R/W	IO_RA_PE	RA_PE	1
0	R/W	IO_RF_PE	RF_PE	1

AUTO_WAKEUP_CFG: AUTO_WAKEUP_CFG Register (offset:0x1208)

Bits	Type	Name	Description	Initial value
31:16	-	-	Reserved	0
15	R/W	AUTO_WAKEUP_EN	Auto wakeup interrupt enable Auto wakeup interrupt will be issued after #(SLEEP_TBTT_NUM) TBTTs' at WAKEUP_LEAD_TIME before the target wakeup TBTT. 0: disable 1: enable Note: Please make sure TBTT_TIMER_EN is enabled.	0
14:8	R/W	SLEEP_TBTT_NUM	Number of sleeping TBTT	0
7:0	R/W	WAKEUP_LEAD_TIME	Auto wakeup lead time (unit: 1TU=1024us)	20

3.20.3.5 MAC TX configuration registers (base: 1018.0000)

EDCA_AC0_CFG (BE): EDCA_AC0_CFG (BE) Register (offset: 0x1300)

Bits	Type	Name	Description	Initial value
31:20	-	-	Reserved	0
19:16	R/W	AC0_CWMAX	AC0 CWMAX (unit: power of 2)	7
15:12	R/W	AC0_CWMIN	AC0 CWMIN (unit: power of 2)	3
11:8	R/W	AC0_AIFSN	AC0 AIFSN (unit: # of slot time)	2
7:0	R/W	AC0_TXOP	AC0 TXOP limit (unit: 32us)	0

EDCA_AC1_CFG (BK): EDCA_AC1_CFG (BK) Register (offset: 0x1304)

Bits	Type	Name	Description	Initial value
31:20	-	-	Reserved	0
19:16	R/W	AC1_CWMAX	AC1 CWMAX (unit: power of 2)	7
15:12	R/W	AC1_CWMIN	AC1 CWMIN (unit: power of 2)	3
11:8	R/W	AC1_AIFSN	AC1 AIFSN (unit: # of slot time)	2
7:0	R/W	AC1_TXOP	AC1 TXOP limit (unit: 32us)	0

EDCA_AC2_CFG (VI): EDCA_AC2_CFG (VI) Register (offset: 0x1308)

Bits	Type	Name	Description	Initial value
31:20	-	-	Reserved	0
19:16	R/W	AC2_CWMAX	AC2 CWMAX (unit: power of 2)	7
15:12	R/W	AC2_CWMIN	AC2 CWMIN (unit: power of 2)	3
11:8	R/W	AC2_AIFSN	AC2 AIFSN (unit: # of slot time)	2
7:0	R/W	AC2_TXOP	AC2 TXOP limit (unit: 32us)	0

EDCA_AC3_CFG (VO): EDCA_AC3_CFG (VO) Register (offset: 0x130C)

Bits	Type	Name	Description	Initial value
31:20	-	-	Reserved	0
19:16	R/W	AC3_CWMAX	AC3 CWMAX (unit: power of 2)	7
15:12	R/W	AC3_CWMIN	AC3 CWMIN (unit: power of 2)	3
11:8	R/W	AC3_AIFSN	AC3 AIFSN (unit: # of slot time)	2
7:0	R/W	AC3_TXOP	AC3 TXOP limit (unit: 32us)	0

EDCA_TID_AC_MAP: EDCA_TID_AC_MAP Register (offset: 0x1310)

Bits	Type	Name	Description	Initial value
31:16	-	-	Reserved	0
15:14	R/W	TID7_AC_MAP	AC value as TID=7	3
13:12	R/W	TID6_AC_MAP	AC value as TID=6	3
11:10	R/W	TID5_AC_MAP	AC value as TID=5	2

9:8	R/W	TID4_AC_MAP	AC value as TID=4	2
7:6	R/W	TID3_AC_MAP	AC value as TID=3	0
5:4	R/W	TID2_AC_MAP	AC value as TID=2	1
3:2	R/W	TID1_AC_MAP	AC value as TID=1	1
1:0	R/W	TID0_AC_MAP	AC value as TID=0	0

Note: default according 802.11e Table 20.23—User priority to Access Category mappings.

TX_PWR_CFG_0: TX_PWR_CFG_0 Register (offset: 0x1314, default: 0x6666_6666)

Bits	Type	Name	Description	Initial value
31:24	R/W	TX_PWR_OFDM_12	TX power for OFDM 12M/18M	0x66
23:16	R/W	TX_PWR_OFDM_6	TX power for OFDM 6M/9M	0x66
15:8	R/W	TX_PWR_CCK_5	TX power for CCK5.5M/11M	0x66
7:0	R/W	TX_PWR_CCK_1	TX power for CCK1M/2M	0x66

TX_PWR_CFG_1: TX_PWR_CFG_1 Register (offset: 0x1318)

Bits	Type	Name	Description	Initial value
31:24	R/W	TX_PWR_MCS_2	TX power for HT MCS=2,3	0x66
23:16	R/W	TX_PWR_MCS_0	TX power for HT MCS=0,1	0x66
15:8	R/W	TX_PWR_OFDM_48	TX power for OFDM 48M/54M	0x66
7:0	R/W	TX_PWR_OFDM_24	TX power for OFDM 24M/36M	0x66

TX_PWR_CFG_2: TX_PWR_CFG_2 Register (offset: 0x131C)

Bits	Type	Name	Description	Initial value
31:24	R/W	TX_PWR_MCS_10	TX power for HT MCS=10,11	0x66
23:16	R/W	TX_PWR_MCS_8	TX power for HT MCS=8,9	0x66
15:8	R/W	TX_PWR_MCS_6	TX power for HT MCS=6,7	0x66
7:0	R/W	TX_PWR_MCS_4	TX power for HT MCS=4,5	0x66

TX_PWR_CFG_3: TX_PWR_CFG_3 Register (offset: 0x1320)

Bits	Type	Name	Description	Initial value
31:24	R/W	-	Reserved	0x66
23:16	R/W	-	Reserved	0x66
15:8	R/W	TX_PWR_MCS_14	TX power for HT MCS=14,15	0x66
7:0	R/W	TX_PWR_MCS_12	TX power for HT MCS=12,13	0x66

TX_PWR_CFG_4: TX_PWR_CFG_4 Register (offset: 0x1324)

Bits	Type	Name	Description	Initial value
31:16	-	-	Reserved	0
15:8	R/W	-	Reserved	0x66
7:0	R/W	-	Reserved	0x66

TX_PIN_CFG: TX_PIN_CFG Register (offset: 0x1328)

Bits	Type	Name	Description	Initial value
31:20	-	-	Reserved	0
19	R/W	TRSW_POL	TRSW_EN polarity	0
18	R/W	TRSW_EN	TRSW_EN enable	1
17	R/W	RFTR_POL	RF_TR polarity	0
16	R/W	RFTR_EN	RF_TR enable	1
15	R/W	LNA_PE_G1_POL	LNA_PE_G1 polarity	0
14	R/W	LNA_PE_A1_POL	LNA_PE_A1 polarity	0
13	R/W	LNA_PE_G0_POL	LNA_PE_G0 polarity	0
12	R/W	LNA_PE_A0_POL	LNA_PE_A0 polarity	0
11	R/W	LNA_PE_G1_EN	LNA_PE_G1 enable	1
10	R/W	LNA_PE_A1_EN	LNA_PE_A1 enable	1
9	R/W	LNA_PE_G0_EN	LNA_PE_G0 enable	1
8	R/W	LNA_PE_A0_EN	LNA_PE_A0 enable	1
7	R/W	PA_PE_G1_POL	PA_PE_G1 polarity	0
6	R/W	PA_PE_A1_POL	PA_PE_A1 polarity	0
5	R/W	PA_PE_G0_POL	PA_PE_G0 polarity	0

4	R/W	PA_PE_A0_POL	PA_PE_A0 polarity	0
3	R/W	PA_PE_G1_EN	PA_PE_G1 enable	1
2	R/W	PA_PE_A1_EN	PA_PE_A1 enable	1
1	R/W	PA_PE_G0_EN	PA_PE_G0 enable	1
0	R/W	PA_PE_A0_EN	PA_PE_A0 enable	1

TX_BAND_CFG: TX_BAND_CFG Register (offset: 0x132C)

Bits	Type	Name	Description	Initial value
31:3	-	-	Reserved	0
2	R/W	5G_BAND_SEL_N	5G band selection PIN (complement of 5G_BAND_SEL_P)	1
1	R/W	5G_BAND_SEL_P	5G band selection PIN	0
0	R/W	TX_BAND_SEL	0: use lower 40Mhz band in 20Mhz TX 1: use upper 40Mhz band in 20Mhz TX	0

Note1: TX_BAND_SEL is effective only when TX/RX bandwidth control register R4 of BBP is set to 40Mhz.

TX_SW_CFG0: TX_SW_CFG0 Register (offset: 0x1330)

Bits	Type	Name	Description	Initial value
31:24	R/W	DLY_RFTR_EN	Delay of RF_TR assertion	0x0
23:16	R/W	DLY_TRSW_EN	Delay of TR_SW assertion	0x4
15:8	R/W	DLY_PAPE_EN	Delay of PA_PE assertion	0x8
7:0	R/W	DLY_TXPE_EN	Delay of TX_PE assertion	0xC

Note1: The timing unit is 0.25us.

Note2: SIFS_TIME should compensate with DLY_TXPE_EN.

TX_SW_CFG1: TX_SW_CFG1 Register (offset: 0x1334)

Bits	Type	Name	Description	Initial value
31:24	-	-	Reserved	0
23:16	R/W	DLY_RFTR_DIS	Delay of RF_TR de-assertion	0xC
15:8	R/W	DLY_TRSW_DIS	Delay of TR_SW de-assertion	0x8
7:0	R/W	DLY_PAPE_DIS	Delay of PA_PE de-assertion	0x8

Note1: The timing unit is 0.25us.

Note2: The delay is started from TX_END event of BBP.

Note3: TX_PE is de-asserted automatically as last data byte passed to BBP.

TX_SW_CFG2: TX_SW_CFG2 Register (offset: 0x1338)

Bits	Type	Name	Description	Initial value
31:24	R/W	DLY_LNA_EN	Delay of LNA* assertion	0x0
23:16	R/W	DLY_LNA_DIS	Delay of LNA* de-assertion	0xC
15:8	R/W	DLY_DAC_EN	Delay of DAC_PE assertion	0x4
7:0	R/W	DLY_DAC_DIS	Delay of DAC_PE de-assertion	0x8

Note1: The timing unit is 0.25us.

Note 2: LNA* includes LNA_A0, LNA_A1, LNA_G0, and LNA_G1.

TXOP_THRES_CFG: TXOP_THRES_CFG Register (offset: 0x133C)

Bits	Type	Name	Description	Initial value
31:24	R/W	TXOP_REM_THRES	Remaining TXOP threshold, unit: 32us As the remaining TXOP is less than the threshold, the TXOP is passed silently.	0
23:16	R/W	CF_END_THRES	CF-END threshold, unit: 32us As the remaining TXOP is greater than the threshold, the CF-END will be sent to release the remaining TXOP reserved by long NAV. Set 0xFF to disable CF_END transmission.	0
15:8	R/W	RDG_IN_THRES	RX RDG threshold, unit: 32us As the remaining TXOP (specified in the duration field of the RX frame with RDG=1) is greater than or equal to the threshold, the granted reverse direction TXOP may be used.	0

7:0	R/W	RDG_OUT_THRES	TX RDG threshold, unit: 32us As the remaining TXOP is greater than or equal to the threshold, RDG in the TX frame may be set to one.	0
-----	-----	---------------	---	---

TXOP_CTRL_CFG: TXOP_CTRL_CFG Register (offset: 0x1340)

Bits	Type	Name	Description	Initial value
31:20	-	-	Reserved	0
19:16	R/W	EXT_CW_MIN	Cwmin for extension channel backoff When EXT_CCA_EN is enabled, 40Mhz transmission will be suppressed to 20Mhz if the extension CCA is busy or extension channel backoff is not finished. Default: Cwmin=0, disable.	0
15:8	R/W	EXT_CCA_DLY	Extension CCA signal delay time (unit: usec) Create delayed version of extension CCA signal reference time for extension channel IFS. Default: (ofdm SIFS) + (long slot time) = 16 + 20 = 36 (usec)	36
7	R/W	EXT_CCA_EN	Extension CCA reference enable When transmit in 40Mhz mode, defer until extension CCA is also clear. 0: disable 1: enable	0
6	R/W	LSIG_TXOP_EN	L-SIG TXOP protection enable Extension of mix mode L-SIG protection range to following ACK/CTS.	0
5:0	R/W	TXOP_TRUN_EN	TXOP truncation enable Bit5: reserved Bit4: truncation for MIMO power save RTS/CTS Bit3: truncation for user TXOP mode Bit2: truncation for TX rate group change Bit1: truncation for AC change Bit0: TXOP timeout truncation 0: disable 1: enable	0x3F

TX_RTS_CFG: TX_RTS_CFG Register (offset: 0x1344)

Bits	Type	Name	Description	Initial value
31:24	-	-	Reserved	0
24	R/W	RTS_FBK_EN	RTS rate fallback enable	0
23:8	R/W	RTS_THRES	RTS threshold (unit: byte) MPDU or AMPDU with length greater than RTS threshold will be protected with RTS/CTS exchange at the beginning of the TXOP.	65535
7:0	R/W	RTS_RTY_LIMIT	Auto RTS retry limit	7

TX_TIMEOUT_CFG: TX_TIMEOUT_CFG Register (offset: 0x1348)

Bits	Type	Name	Description	Initial value
31:24	-	-	Reserved	0
23:16	R/W	TXOP_TIMEOUT	TXOP timeout value for TXOP truncation Unit: 1usec Note: It is recommended that (SLOT_TIME) > (TXOP_TIMEOUT) > (RX_ACK_TIMEOUT) Default: For 20us long slot time.	15
15:8	R/W	RX_ACK_TIMEOUT	RX ACK/CTS timeout value for TX procedure Unit: 1usec Note: It is recommended that (SLOT_TIME) >	10

			(TXOP_TIMEOUT) > (RX_ACK_TIMEOUT) Default: For 20us long slot time.	
7:4	R/W	MPDU_LIFE_TIME	TX MPDU expiration time Expiration time = 2^(9+MPDU_LIFE_TIME) us Default value is 2^(9+9) ~= 256ms	9
3:0	-	-	Reserved	0

TX_RTY_CFG: TX_RTY_CFG Register (offset: 0x134C)

Bits	Type	Name	Description	Initial value
31	-	-	Reserved	0
30	R/W	TX_AUTOFB_EN	TX retry PHY rate auto fallback enable 0: disable 1: enable	0
29	R/W	AGG_RTY_MODE	Aggregate MPDU retry mode 0: expired by retry limit 1: expired by MPDU life timer	1
28	R/W	NAG_RTY_MODE	Non-aggregate MPDU retry mode 0: expired by retry limit 1: expired by MPDU life timer	0
27:16	R/W	LONG_RTY_THRES	Long retry threshold MPDU with length over this threshold is applied with long retry limit.	3000
15:8	R/W	LONG_RTY_LIMIT	Long retry limit	4
7:0	R/W	SHORT_RTY_LIMIT	Short retry limit	7

TX_LINK_CFG: TX_LINK_CFG Register (offset: 0x1350)

Bits	Type	Name	Description	Initial value
31:24	R	REMOTE_MFS	Remote MCS feedback sequence number	*
23:16	R	REMOTE_MFB	Remote MCS feedback	0x7F
15:13	-	-	Reserved	0
12	R/W	TX_CFACK_EN	Piggyback CF-ACK enable 0: disable 1: enable	0
11	R/W	TX_RDG_EN	RDG TX enable 0: disable 1: enable	0
10	R/W	TX_MRQ_EN	MCS request TX enable 0: disable 1: enable	0
9	R/W	REMOTE_UMFS_EN	Remote un-solicit MFB enable 0: do not apply remote un-solicit MFB (MFS=7) 1: apply un-solicit MFB	0
8	R/W	TX_MFB_EN	TX apply remote MFB 0: disable 1: enable	0
7:0	R/W	REMOTE_MFB_LITE TIME	Remote MFB life time Unit: 32us	32

HT_FBK_CFG0: HT_FBK_CFG0 Register (offset: 0x1354)

Bits	Type	Name	Description	Initial value
31:28	R/W	HT_MCS7_FBK	Auto fall back MCS as HT MCS =7	6
27:24	R/W	HT_MCS6_FBK	Auto fall back MCS as HT MCS =6	5
23:20	R/W	HT_MCS5_FBK	Auto fall back MCS as HT MCS =5	4
19:16	R/W	HT_MCS4_FBK	Auto fall back MCS as HT MCS =4	3
15:12	R/W	HT_MCS3_FBK	Auto fall back MCS as HT MCS =3	2

11:8	R/W	HT_MCS2_FBK	Auto fall back MCS as HT MCS =2	1
7:4	R/W	HT_MCS1_FBK	Auto fall back MCS as HT MCS =1	0
3:0	R/W	HT_MCS0_FBK	Auto fall back MCS as HT MCS =0	0

HT_FBK_CFG1: HT_FBK_CFG1 Register (offset: 0x1358)

Bits	Type	Name	Description	Initial value
31:28	R/W	HT_MCS15_FBK	Auto fall back MCS as HT MCS =15	14
27:24	R/W	HT_MCS14_FBK	Auto fall back MCS as HT MCS =14	13
23:20	R/W	HT_MCS13_FBK	Auto fall back MCS as HT MCS =13	12
19:16	R/W	HT_MCS12_FBK	Auto fall back MCS as HT MCS =12	11
15:12	R/W	HT_MCS11_FBK	Auto fall back MCS as HT MCS =11	10
11:8	R/W	HT_MCS10_FBK	Auto fall back MCS as HT MCS =10	9
7:4	R/W	HT_MCS9_FBK	Auto fall back MCS as HT MCS =9	8
3:0	R/W	HT_MCS8_FBK	Auto fall back MCS as HT MCS =8	8

Note1. The MCS is a fallback stopping state, as the fallback MCS is the same as current MCS.

Note2. HT TX PHY rates will not fallback to legacy PHY rates.

LG_FBK_CFG0: LG_FBK_CFG0 Register (offset: 0x135C)

Bits	Type	Name	Description	Initial value
31:28	R/W	OFDM7_FBK	Auto fall back MCS as previous TX rate is OFDM 54Mbps.	14
27:24	R/W	OFDM6_FBK	Auto fall back MCS as previous TX rate is OFDM 48Mbps.	13
23:20	R/W	OFDM5_FBK	Auto fall back MCS as previous TX rate is OFDM 36Mbps.	12
19:16	R/W	OFDM4_FBK	Auto fall back MCS as previous TX rate is OFDM 24Mbps.	11
15:12	R/W	OFDM3_FBK	Auto fall back MCS as previous TX rate is OFDM 18Mbps.	10
11:8	R/W	OFDM2_FBK	Auto fall back MCS as previous TX rate is OFDM 12Mbps.	9
7:4	R/W	OFDM1_FBK	Auto fall back MCS as previous TX rate is OFDM 9Mbps.	8
3:0	R/W	OFDM0_FBK	Auto fall back MCS as previous TX rate is OFDM 6Mbps.	8

LG_FBK_CFG1: LG_FBK_CFG1 Register (offset: 0x1360)

Bits	Type	Name	Description	Initial value
31:16	-	-	Reserved	0
15:12	R/W	CCK3_FBK	Auto fall back MCS as previous TX rate is CCK 11Mbps.	2
11:8	R/W	CCK2_FBK	Auto fall back MCS as previous TX rate is CCK 5.5Mbps.	1
7:4	R/W	CCK1_FBK	Auto fall back MCS as previous TX rate is CCK 2Mbps.	0
3:0	R/W	CCK0_FBK	Auto fall back MCS as previous TX rate is CCK 1Mbps.	0

Note1. Bit3 of each legacy fallback rate is selection of OFDM/CCK. 0=CCK, 1=OFDM.

CCK_PROT_CFG: CCK_PROT_CFG Register (offset: 0x1364)

Bits	Type	Name	Description	Initial value
31:27	-	-	Reserved	0
26	R/W	CCK_RTSTH_EN	RTS threshold enable on CCK TX 0: disable 1: enable	0
25:20	R/W	CCK_TXOP_ALLOW	CCK TXOP allowance (0: disallow, 1: allow) Bit25: allow GF-40 TX Bit24: allow GF-20 TX Bit23: allow MM-40 TX Bit22: allow MM-20 TX Bit21: allow OFDM TX Bit20: allow CCK TX	1
19:18	R/W	CCK_PROT_NAV	TXOP protection type for CCK TX 0: None 1: Short NAV protection 2: Long NAV protection 3: Reserved (None)	0

17:16	R/W	CCK_PROT_CTRL	Protection control frame type for CCK TX 0: None 1: RTS/CTS 2: CTS-to-self 3: Reserved (None)	0
15:0	R/W	CCK_PROT_RATE	Protection control frame rate for CCK TX (Including RTS/CTS-to-self/CF-END) Default: CCK 11M	0x0003

OFDM_PROT_CFG: OFDM_PROT_CFG Register (offset: 0x1368)

Bits	Type	Name	Description	Initial value
31:27	-	-	Reserved	0
26	R/W	OFDM_RTSTH_EN	RTS threshold enable on OFDM TX 0: disable 1: enable	0
25:20	R/W	OFDM_PROT_TXOP	OFDM TXOP allowance (0: disallow, 1: allow) Bit25: allow GF-40 TX Bit24: allow GF-20 TX Bit23: allow MM-40 TX Bit22: allow MM-20 TX Bit21: allow OFDM TX Bit20: allow CCK TX	2
19:18	R/W	OFDM_PROT_NAV	TXOP protection type for OFDM TX 0: None 1: Short NAV protection 2: Long NAV protection 3: Reserved (None)	0
17:16	R/W	OFDM_PROT_CTRL	Protection control frame type for OFDM TX 0: None 1: RTS/CTS 2: CTS-to-self 3: Reserved (None)	0
15:0	R/W	OFDM_PROT_RATE	Protection control frame rate for OFDM TX (Including RTS/CTS-to-self/CF-END) Default: CCK 11M	0x0003

MM20_PROT_CFG: MM20_PROT_CFG Register (offset: 0x136C)

Bits	Type	Name	Description	Initial value
31:27	-	-	Reserved	0
26	R/W	MM20_RTSTH_EN	RTS threshold enable on MM20 TX 0: disable 1: enable	0
25:20	R/W	MM20_PROT_TXOP	MM20 TXOP allowance (0: disallow, 1: allow) Bit25: allow GF-40 TX Bit24: allow GF-20 TX Bit23: allow MM-40 TX Bit22: allow MM-20 TX Bit21: allow OFDM TX Bit20: allow CCK TX	4
19:18	R/W	MM20_PROT_NAV	TXOP protection type for MM20 TX 0: None 1: Short NAV protection 2: Long NAV protection 3: Reserved (None)	0

17:16	R/W	MM20_PROT_CTRL	Protection control frame type for MM20 TX 0: None 1: RTS/CTS 2: CTS-to-self 3: Reserved (None)	0
15:0	R/W	MM20_PROT_RATE	Protection control frame rate for MM20 TX (Including RTS/CTS-to-self/CF-END) Default: OFDM 24M	0x4004

MM40_PROT_CFG: MM40_PROT_CFG Register (offset: 0x1370)

Bits	Type	Name	Description	Initial value
31:27	-	-	Reserved	0
26	R/W	MM40_RTSTH_EN	RTS threshold enable on MM40 TX 0: disable 1: enable	0
25:20	R/W	MM40_PROT_TXOP	MM40 TXOP allowance (0: disallow, 1: allow) Bit25: allow GF-40 TX Bit24: allow GF-20 TX Bit23: allow MM-40 TX Bit22: allow MM-20 TX Bit21: allow OFDM TX Bit20: allow CCK TX	8
19:18	R/W	MM40_PROT_NAV	TXOP protection type for MM40 TX 0: None 1: Short NAV protection 2: Long NAV protection 3: Reserved (None)	0
17:16	R/W	MM40_PROT_CTRL	Protection control frame type for MM40 TX 0: None 1: RTS/CTS 2: CTS-to-self 3: Reserved (None)	0
15:0	R/W	MM40_PROT_RATE	Protection control frame rate for MM40 TX (Including RTS/CTS-to-self/CF-END) Default: duplicate OFDM 24M	0x4084

GF20_PROT_CFG: GF20_PROT_CFG Register (offset: 0x1374)

Bits	Type	Name	Description	Initial value
31:27	-	-	Reserved	0
26	R/W	GF20_RTSTH_EN	RTS threshold enable on GF20 TX 0: disable 1: enable	0
25:20	R/W	GF20_PROT_TXOP	GF20 TXOP allowance (0: disallow, 1: allow) Bit25: allow GF-40 TX Bit24: allow GF-20 TX Bit23: allow MM-40 TX Bit22: allow MM-20 TX Bit21: allow OFDM TX Bit20: allow CCK TX	16
19:18	R/W	GF20_PROT_NAV	TXOP protection type for GF20 TX 0: None 1: Short NAV protection 2: Long NAV protection 3: Reserved (None)	0
17:16	R/W	GF20_PROT_CTRL	Protection control frame type for GF20 TX	0

			0: None 1: RTS/CTS 2: CTS-to-self 3: Reserved (None)	
15:0	R/W	GF20_PROT_RATE	Protection control frame rate for GF20 TX (Including RTS/CTS-to-self/CF-END) Default: OFDM 24M	0x4004

GF40_PROT_CFG: GF40_PROT_CFG Register (offset: 0x1378)

Bits	Type	Name	Description	Initial value
31:27	-	-	Reserved	0
26	R/W	GF40_RTSTH_EN	RTS threshold enable on GF40 TX 0: disable 1: enable	0
25:20	R/W	GF40_PROT_TXOP	GF40 TXOP allowance (0: disallow, 1: allow) Bit25: allow GF-40 TX Bit24: allow GF-20 TX Bit23: allow MM-40 TX Bit22: allow MM-20 TX Bit21: allow OFDM TX Bit20: allow CCK TX	16
19:18	R/W	GF40_PROT_NAV	TXOP protection type for GF40 TX 0: None 1: Short NAV protection 2: Long NAV protection 3: Reserved (None)	0
17:16	R/W	GF40_PROT_CTRL	Protection control frame type for GF40 TX 0: None 1: RTS/CTS 2: CTS-to-self 3: Reserved (None)	0
15:0	R/W	GF40_PROT_RATE	Protection control frame rate for GF40 TX (Including RTS/CTS-to-self/CF-END) Default: duplicate OFDM 24M	0x4084

EXP_CTS_TIME: EXP_CTS_TIME Register (offset: 0x137C)

Bits	Type	Name	Description	Initial value
31	-	-	Reserved	0
30:16	R/W	EXP_OFDM_CTS_TIME	Expected time for OFDM CTS response (unit: 1us) Used for outgoing NAV setting. Default: SIFS + 6Mbps CTS	56
15	R	-	Reserved	0
14:0	R/W	EXP_CCK_CTS_TIME	Expected time for CCK CTS response (unit: 1us) Used for outgoing NAV setting. Default: SIFS + 1Mbps CTS	314

EXP_ACK_TIME: EXP_ACK_TIME Register (offset: 0x1380)

Bits	Type	Name	Description	Initial value
31	-	-	Reserved	0
30:16	R/W	EXP_OFDM_ACK_TIME	Expected time for OFDM ACK response (unit: 1us) Used for outgoing NAV setting. Default: SIFS + 6Mbps ACK preamble	36
15	-	-	Reserved	0
14:0	R/W	EXP_CCK_ACK_TIME	Expected time for OFDM ACK response (unit: 1us)	202

		E	Used for outgoing NAV setting. Default: SIFS + 1Mbps ACK preamble	
--	--	---	--	--

3.20.3.6 MAC RX configuration registers (base: 1018.0000)

RX_FILTR_CFG: RX_FILTR_CFG Register (offset: 0x1400)

Bits	Type	Name	Description	Initial value
31:17	-	-	Reserved	0
16	R/W	DROP_CTRL_RSV	Drop reserve control subtype	1
15	R/W	DROP_BAR	Drop BAR	0
14	R/W	DROP_BA	Drop BA	1
13	R/W	DROP_PSPOLL	Drop PS-Poll	0
12	R/W	DROP_RTS	Drop RTS	1
11	R/W	DROP_CTS	Drop CTS	1
10	R/W	DROP_ACK	Drop ACK	1
9	R/W	DROP_CFEND	Drop CF-END	1
8	R/W	DROP_CFAK	Drop CF-END + CF-ACK	1
7	R/W	DROP_DUPL	Drop duplicated frame	1
6	R/W	DROP_BC	Drop broadcast frame	0
5	R/W	DROP_MC	Drop multicast frame	0
4	R/W	DROP_VER_ERR	Drop 802.11 version error frame	1
3	R/W	DROP_NOT_MYBSS	Drop frame that is not my BSSID	1
2	R/W	DROP_UC_NOME	Drop not to me unicast frame	1
1	R/W	DROP_PHY_ERR	Drop physical error frame	1
0	R/W	DROP_CRC_ERR	Drop CRC error frame	1

Note: 1: enable, 0: disable.

AUTO_RSP_CFG: AUTO_RSP_CFG Register (offset: 0x1404)

Bits	Type	Name	Description	Initial value
31:8	-	-	Reserved	0
7	R/W	CTRL_PWR_BIT	Power bit value in control frame	0
6	R/W	BAC_ACK_POLICY	BA frame -> BAC -> Ack policy bit value	0
5	-	-	Reserved	0
4	R/W	CCK_SHORT_EN	CCK short preamble auto response enable 0: disable 1: enable	0
3	R/W	CTS_40M_REF	In duplicate legacy CTS response mode, refer to extension CCA to decide duplicate or not. 0: disable 1: enable	0
2	R/W	CTS_40M_MODE	Duplicate legacy CTS response mode 0: disable 1: enable	0
1	R/W	BAC_ACKPOLICY_EN	BAC ACK policy bit enable 0: disable; don't care this bit 1: enable; no BA auto responding upon reception of BAR with no ACK policy	1
0	R/W	AUTO_RSP_EN	Auto responder enable	1

LEGACY_BASIC_RATE: LEGACY_BASIC_RATE Register (offset: 0x1408)

Bits	Type	Name	Description	Initial value
31: 12	-	-	Reserved	0
11: 0	R/W	LEGACY_BASIC_RATE	Legacy basic rate bit mask Bit0: 1 Mbps is basic rate Bit1: 2 Mbps is basic rate	0

			Bit2: 5.5 Mbps is basic rate Bit3: 11 Mbps is basic rate Bit4: 6 Mbps is basic rate Bit5: 9 Mbps is basic rate Bit6: 12 Mbps is basic rate Bit7: 18 Mbps is basic rate Bit8: 24 Mbps is basic rate Bit9: 36 Mbps is basic rate Bit10: 48 Mbps is basic rate Bit11: 54 Mbps is basic rate 0: disable 1: enable	
--	--	--	--	--

HT_BASIC_RATE: HT_BASIC_RATE Register (offset: 0x140C)

Bits	Type	Name	Description	Initial value
31: 16	R/W	-	Reserved	0
15: 0	R/W	HT_BASIC_RATE	HT basic rate for auto responding control frame Bit15 =1, enable MCS feedback	0

HT_CTRL_CFG: HT_CTRL_CFG Register (offset: 0x1410)

Bits	Type	Name	Description	Initial value
31: 9	-	-	Reserved	0
8: 0	R/W	HT_CTRL_THRES	Remaining TXOP threshold for HT control frame auto responding (unit: us)	256

SIFS_COST_CFG: SIFS_COST_CFG Register (offset: 0x1414)

Bits	Type	Name	Description	Initial value
31:16	-	-	Reserved	0
15:8	R/W	OFDM_SIFS_COST	OFDM SIFS time (unit: 1us) Applied after OFDM TX/RX.	16
7:0	R/W	CCK_SIFS_COST	CCK SIFS time (unit: 1us) Applied after CCK TX/RX.	10

Note: The OFDM_SIFS_COST and CCK_SIFS_COST are used only for duration field calculation. It will not affect the responding timing.

RX_PARSER_CFG: RX_PARSER_CFG Register (offset: 0x1418)

Bits	Type	Name	Description	Initial value
31:16	-	-	Reserved	0
0	R/W	NAV_ALL_EN	Set NAV for all received frames 0: disable (unicast to me frame will not set the NAV) 1: enable	0

3.20.3.7 MAC Security Configuration Registers (base: 1018.0000)

TX_SEC_CNT0: TX_SEC_CNT0 Register (offset: 0x1500)

Bits	Type	Name	Description	Initial value
31:16	RC	TX_SEC_ERR_CNT	TX SEC packet error count	0
15:0	RC	TX_SEC_CPL_CNT	TX SEC packet complete count	0

RX_SEC_CNT0: RX_SEC_CNT0 Register (offset: 0x1504)

Bits	Type	Name	Description	Initial value
31:16	-	-	Reserved	0
15:0	RC	RX_SEC_CPL_CNT	RX SEC packet complete count	0

CCMP_FC_MUTE: CCMP_FC_MUTE Register (offset: 0x1508)

Bits	Type	Name	Description	Initial value
31:16	R/W	HT_CCMP_FC_MUTE	HT rate CCMP FC mute	0xc78f
15:0	R/W	LG_CCMP_FC_MUTE	Legacy rate CCMP FC mute	0xc78f

3.20.3.8 MAC HCCA/PSMP CSR (base: 1018.0000)

TXOP_HLDR_ADDR0: TXOP_HLDR_ADDR0 Register (offset: 0x1600)

Bits	Type	Name	Description	Initial value
31:24	R/W	TXOP_HOL_3	TXOP holder MAC address byte3	0
23:16	R/W	TXOP_HOL_2	TXOP holder MAC address byte2	0
15:8	R/W	TXOP_HOL_1	TXOP holder MAC address byte1	0
7:0	R/W	TXOP_HOL_0	TXOP holder MAC address byte0	0

TXOP_HLDR_ADDR1: TXOP_HLDR_ADDR1 Register (offset: 0x1604)

Bits	Type	Name	Description	Initial value
31:16	-	-	Reserved	0
15:8	R/W	TXOP_HOL_5	TXOP holder MAC address byte5	0
7:0	R/W	TXOP_HOL_4	TXOP holder MAC address byte4	0

Note: Byte0 is the first byte on the network. Its LSB bit is the first bit on network. For a MAC address captured on the network with order 00:01:02:03:04:05, byte0=00, byte1=01 etc.

TXOP_HLDR_ET: TXOP_HLDR_ET Register (offset: 0x1608)

Bits	Type	Name	Description	Initial value
31:26	-	-	Reserved	0
25	R/W	TXOP_ETM1_EN	TXOP holder early termination interrupt enable (Type 1) Upon the reception of QoS data frame from TXOP_HLDR_ADDR (A2) and Queue size (QS) in QOS control field (QC) is equal to zero, "TXOP holder early termination interrupt" will be issued. 0: disable 1: enable	0
24	R/W	TXOP_ETM0_EN	TXOP holder early termination interrupt enable (Type 0) When RX packet is from TXOP holder specified in QOS_CSR0,1 (match with Addr2) and duration value is less than or equal to early termination duration threshold specified below, "TXOP holder early termination" interrupt will be issued after CRC check is ok. Upon the reception of QoS data frame from TXOP_HLDR_ADDR (A2) and Duration (DUR) is less than or equal to early termination duration threshold (TXOP_ETM_THRES), "TXOP holder early termination interrupt" will be issue. 0: disable 1: enable	0
23:16	R/W	TXOP_ETM_THRES	TXOP early termination duration threshold Unit: 1usec	0
15:9	-	-	Reserved	0

8	WC	TXOP_ETO_EN	TXOP holder early timeout enable Write 1 to enable early timeout check. (interrupt when timeout) When enabled, hardware will expect CCA event. If hardware didn't sense CCA over the TXOP holder early timeout threshold (TXOP_ETO_THRES), the "TXOP holder early timeout interrupt" will then be issued.	0
7:1	R/W	TXOP_ETO_THRES	TXOP holder early timeout threshold Unit: 1usec	0
0	R/W	PER_RX_RST_EN	Baseband RX_PE per RX reset enable 0: disable, 1: enable	0

Note1: TXOP holder early timeout interrupt (TXOP_ETO_INT) is used by AP for HC purpose.

Note2: TXOP holder early termination interrupt (TXOP_ETM_INT) is used by STA (both AP and non-AP STA) for HC purpose.

QOS_CFPOLL_RA_DW0: QOS_CFPOLL_RA_DW0 Register (offset: 0x160C)

Bits	Type	Name	Description	Initial value
31:24	R	CFPOLL_A1_BYTE3	Byte3 of A1 of received QoS Data (+) CF-Poll frame	X
23:16	R	CFPOLL_A1_BYTE2	Byte2 of A1 of received QoS Data (+) CF-Poll frame	X
15:8	R	CFPOLL_A1_BYTE1	Byte1 of A1 of received QoS Data (+) CF-Poll frame	X
7:0	R	CFPOLL_A1_BYTE0	Byte0 of A1 of received QoS Data (+) CF-Poll frame	X

QOS_CFPOLL_A1_DW1: QOS_CFPOLL_RA_DW1 Register (offset: 0x1610)

Bits	Type	Name	Description	Initial value
31:24	-	-	Reserved	0
16	R	CFPOLL_A1_TOME	1: QoS CF-Poll to me 0: Qos CF-Poll not to me	X
15:8	R	CFPOLL_A1_BYTE5	Byte5 of A1 of received QoS Data (+) CF-Poll frame	X
7:0	R	CFPOLL_A1_BYTE4	Byte4 of A1 of received QoS Data (+) CF-Poll frame	X

QOS_CFPOLL_QC: QOS_CFPOLL_QC Register (offset: 0x1614)

Bits	Type	Name	Description	Initial value
31:24	-	-	Reserved	0
15:8	R	CFPOLL_QC_BYTE1	Byte1 of QC of received QoS Data (+) CF-Poll frame	X
7:0	R	CFPOLL_QC_BYTE0	Byte0 of QC of received QoS Data (+) CF-Poll frame	X

Note: CFPOLL_RA_DW0, CFPOLL_RA_DW1, and CFPOLL_QC are updated after the reception of QoS Data (+) CF-Poll frame and RX QoS CF-Poll interrupt (RX_QOS_CFPOLL_INT) is launched then

3.20.3.9 MAC Statistic Counters (base: 1018.0000)

RX_STA_CNT0: RX_STA_CNT0 Register (offset: 0x1700)

Bits	Type	Name	Description	Initial value
31:16	RC	PHY_ERRCNT	RX PHY error frame count	0
15:0	RC	CRC_ERRCNT	RX CRC error frame count	0

Note1: An RX PHY error means PSDU length is shorter than indicated by PLCP.

Note2: An RX PHY error is also treated as CRC error.

RX_STA_CNT1: RX_STA_CNT1 Register (offset: 0x1704)

Bits	Type	Name	Description	Initial value
31:16	RC	PLPC_ERRCNT	RX PLCP error count	0
15:0	RC	CCA_ERRCNT	CCA false alarm count	0

Note1: CCA false alarm means there is no PLCP after CCA indication.

Note2: RX PLCP error means there is no PSDU after PLCP indication.

RX_STA_CNT2: RX_STA_CNT2 Register (offset: 0x1708)

Bits	Type	Name	Description	Initial value
31:16	RC	RX_OVFL_CNT	RX FIFO overflow frame count	0
15:0	RC	RX_DUPL_CNT	RX duplicated filtered frame count	0

Note: MAC will NOT auto respond ACK/BA to the frame originator when frame is lost due to RXFIFO overflow. However, MAC will respond when frame is duplicated filtered.

TX_STA_CNT0: TX_STA_CNT0 Register (offset: 0x170C)

Bits	Type	Name	Description	Initial value
31:16	RC	TX_BCN_CNT	TX beacon count	0
15:0	RC	TX_FAIL_CNT	Failed TX count	0

TX_STA_CNT1: TX_STA_CNT1 Register (offset: 0x1710)

Bits	Type	Name	Description	Initial value
31:16	RC	TX_RTY_CNT	TX retransmission count	0
15:0	RC	TX_SUCC_CNT	Successful TX count	0

TX_STA_CNT2: TX_STA_CNT2 Register (offset: 0x1714)

Bits	Type	Name	Description	Initial value
31:16	RC	TX_UDFL_CNT	TX underflow count	0
15:0	RC	TX_ZERO_CNT	TX zero length frame count	0

TX_STAT_FIFO: TX_STAT_FIFO Register (offset: 0x1718)

Bits	Type	Name	Description	Initial value
31:16	R	TXQ_RATE	TX success rate	*
15:8	R	TXQ_WCID	TX WCID	*
7	R	TXQ_ACKREQ	TX acknowledge required 0: not required 1: required	*
6	R	TXQ_AGG	TX aggregate 0: non-aggregated 1: aggregated	*
5	R	TXQ_OK	TX success 0: failed 1: success	*
4:1	R	TXQ_PID	TX Packet ID (Latched from TXWI)	*
0	RC	TXQ_VLD	TX status queue valid 0: queue empty, 1: valid	0

Note: TX status FIFO size = 16.

TX_NAG_AGG_CNT: TX_NAG_AGG_CNT Register (offset: 0x171C)

Bits	Type	Name	Description	Initial value
31:16	RC	TX_AGG_CNT	Aggregate TX count	0
15:0	RC	TX_NAG_CNT	Non-aggregate TX count	0

TX_AGG_CNT0: TX_AGG_CNT0 Register (offset: 0x1720)

Bits	Type	Name	Description	Initial value
31:16	RC	TX_AGG_2_CNT	Aggregate Size = 2 MPDU count	0
15:0	RC	TX_AGG_1_CNT	Aggregate Size = 1 MPDU count	0

TX_AGG_CNT1: TX_AGG_CNT1 Register (offset: 0x1724)

Bits	Type	Name	Description	Initial value
31:16	RC	TX_AGG_4_CNT	Aggregate Size = 4 MPDU count	0
15:0	RC	TX_AGG_3_CNT	Aggregate Size = 3 MPDU count	0

TX_AGG_CNT2: TX_AGG_CNT2 Register (offset: 0x1728)

Bits	Type	Name	Description	Initial value
31:16	RC	TX_AGG_6_CNT	Aggregate Size = 6 MPDU count	0
15:0	RC	TX_AGG_5_CNT	Aggregate Size = 5 MPDU count	0

TX_AGG_CNT3: TX_AGG_CNT3 Register (offset: 0x172C)

Bits	Type	Name	Description	Initial value
31:16	RC	TX_AGG_8_CNT	Aggregate Size = 8 MPDU count	0
15:0	RC	TX_AGG_7_CNT	Aggregate Size = 7 MPDU count	0

TX_AGG_CNT4: TX_AGG_CNT4 Register (offset: 0x1730)

Bits	Type	Name	Description	Initial value
31:16	RC	TX_AGG_10_CNT	Aggregate Size = 10 MPDU count	0
15:0	RC	TX_AGG_9_CNT	Aggregate Size = 9 MPDU count	0

TX_AGG_CNT5: TX_AGG_CNT5 Register (offset: 0x1734)

Bits	Type	Name	Description	Initial value
31:16	RC	TX_AGG_12_CNT	Aggregate Size = 12 MPDU count	0
15:0	RC	TX_AGG_11_CNT	Aggregate Size = 11 MPDU count	0

TX_AGG_CNT6: TX_AGG_CNT6 Register (offset: 0x1738)

Bits	Type	Name	Description	Initial value
31:16	RC	TX_AGG_14_CNT	Aggregate Size = 14 MPDU count	0
15:0	RC	TX_AGG_13_CNT	Aggregate Size = 13 MPDU count	0

TX_AGG_CNT7: TX_AGG_CNT7 Register (offset: 0x173C)

Bits	Type	Name	Description	Initial value
31:16	RC	TX_AGG_16_CNT	Aggregate Size > 16 MPDU count	0
15:0	RC	TX_AGG_15_CNT	Aggregate Size = 15 MPDU count	0

MPDU_DENSITY_CNT: MPDU_DENSITY_CNT Register (offset: 0x1740)

Bits	Type	Name	Description	Initial value
31:16	RC	RX_ZERO_DEL_CNT	RX zero length delimiter count	0
15:0	RC	TX_ZERO_DEL_CNT	TX zero length delimiter count	0

3.20.3.10 MAC search table (base: 0x1018.0000)

RX_WC_SEF: RX WCID Search Entry Format (8 bytes)

Offset	Type	Name	Description	Initial value
0x00	R/W	WC_MAC_ADDR0	Client MAC address byte0	0x00
0x01	R/W	WC_MAC_ADDR1	Client MAC address byte1	0x00
0x02	R/W	WC_MAC_ADDR2	Client MAC address byte2	0x00
0x03	R/W	WC_MAC_ADDR3	Client MAC address byte3	0x00
0x04	R/W	WC_MAC_ADDR4	Client MAC address byte4	0x00
0x05	R/W	WC_MAC_ADDR5	Client MAC address byte5	0x00
0x06	R/W	BA_SESS_MASK0	BA session mask (lower) Bit0 for TID0 Bit7 for TID7	0x00
0x07	R/W	BA_SESS_MASK1	BA session mask (upper) Bit8 for TID8 Bit15 for TID15	0x00

RX_WC_ST: RX WCID Search Table (offset: 0x1800)

Offset	Type	Name	Description	Initial value
0x1800	R/W	WC_ENTRY_0	WC MAC address with WCID=0	0
0x1808	R/W	WC_ENTRY_1	WC MAC address with WCID=1	0
....	R/W	WC MAC address with WCID=2~253	0
0x1FF0	R/W	WC_ENTRY_254	WC MAC address with WCID=254	0
0x1FF8	R/W	WC_ENTRY_255	Reserved (shall not be used)	0

Note1: WCID=Wireless Client ID.

3.20.3.11 Security table/CIS/Beacon/NULL frame (base: 0x1018.0000, offset: 0x4000)

SKF: Security Key Format (8DW)

Offset	Type	Name	Description	Initial value
0x00	R/W	SECKEY_DW0	Security key byte3~0	*
0x04	R/W	SECKEY_DW1	Security key byte7~4	*
0x08	R/W	SECKEY_DW2	Security key byte11~8	*
0x0C	R/W	SECKEY_DW3	Security key byte15~12	*
0x10	R/W	TXMIC_DW0	TX MIC key byte3~0	*
0x14	R/W	TXMIC_DW1	TX MIC key byte7~4	*
0x18	R/W	RXMIC_DW0	RX MIC key byte3~0	*
0x1C	R/W	RXMIC_DW1	RX MIC key byte7~4	*

- Note: 1. For WEP40, CKIP40, only byte 4 ~ 0 of security key are valid.
 2. For WEP104, CKIP104, only byte 12 ~ 0 of security key are valid.
 3. For TKIP, AES, all the bytes of security key are valid.
 4. TX/RX MIC key is used only for TKIP MIC calculation.

IV/EIV_F: IV/EIV format (2 DW)

When TXINFO.WIV=0, hardware will auto lookup IV/EIV from this table and update IV/EIV after encryption is finished.

Offset	Type	Name	Description	Initial value
0x00	R/W	IV_FIELED	IV field	*
0x04	R/W	EIV_FIELED	EIV field	*

Note1: The key index and extension IV bit shall be initialized by software. The MSB octet of IV will not be modified by hardware

Note2: IV/EIV packet number (PN) counter modes:

- For WEP40, WEP104, CKIP40, CKIP104, CKIP128 mode, PN=IV[23:0]. EIV[31:0] is not used.
- For TKIP mode, PN = {EIV[31:0], IV[7:0], IV[23:16]}, IV[15:8]=(IV[7:0] | 0x20) & 0x7f is generated by hardware.
- For AES-CCMP, PN = {EIV[31:0], IV[15:0]}
- PN = PN + 1 after each encryption.

Note3: Software may initialize the PN counter to any value.

WCID_AEF: WCID Attribute Entry Format (1DW)

Offset	Type	Name	Description	Initial value
31:10	-	-	Reserved	*
9:7	R/W	RXWI_UDF	RXWI user define field This field is tagged in the RXWI.UDF fields for the WCID.	*
6:4	R/W	BSS_IDX	Multiple-BSS index for the WCID	*
3:1	R/W	RX_PKEY_MODE	Pair-wise key security mode 0: No security 1: WEP40 2: WEP104 3: TKIP 4: AES-CCMP 5: CKIP40 6: CKIP104 7: CKIP128	*
0	R/W	RX_PKEY_EN	Key table selection 0: shared key table 1: pair-wise key table	*

SKME: Share Key Mode Entry Format (1DW)

Bits	Type	Name	Description	Initial value
31	-	-	Reserved	*
30:28	R/W	SKEY_MODE_7+	Shared key7+(8x) mode, x=0~3	*

27	-	-	Reserved	*
26:24	R/W	SKEY_MODE_6+	Shared key6+(8x) mode, x=0~3	*
23	-	-	Reserved	*
22:20	R/W	SKEY_MODE_5+	Shared key5+(8x) mode, x=0~3	*
19	-	-	Reserved	*
18:16	R/W	SKEY_MODE_4+	Shared key4+(8x) mode, x=0~3	*
15	-	-	Reserved	*
14:12	R/W	SKEY_MODE_3+	Shared key3+(8x) mode, x=0~3	*
11	-	-	Reserved	*
10:8	R/W	SKEY_MODE_2+	Shared key2+(8x) mode, x=0~3	*
7	-	-	Reserved	*
6:4	R/W	SKEY_MODE_1+	Shared key1+(8x) mode, x=0~3	*
3	-	-	Reserved	*
2:0	R/W	SKEY_MODE_0+	Shared key0+(8x) mode, x=0~3	*

Key mode definition:

- 0: No security
- 1: WEP40
- 2: WEP104
- 3: TKIP
- 4: AES-CCMP
- 5: CKIP40
- 6: CKIP104
- 7: CKIP128

3.20.3.12 Security Table

PWKT: Pair-Wise Key Table (offset: 0x4000)

Offset	Type	Name	Description	Initial value
0x4000	R/W	PKEY_0	Pair-wise key for WCID0	*
0x4020	R/W	PKEY_1	Pair-wise key for WCID1	*
....	R/W	Pair-wise key for WCID2~253	*
0x5FC0	R/W	PKEY_254	Pair-wise key for WCID254	*
0x5FE0	R/W	PKEY_255	Pair-wise key for WCID255 (not used)	*

IV/EIV_T: IV/EIV table (offset: 0x6000)

Offset	Type	Name	Description	Initial value
0x6000	R/W	IVEIV_0	IV/EIV for WCID0	*
0x6008	R/W	IVEIV_1	IV/EIV for WCID1	*
....	R/W	IV/EIV for WCID2~253	*
0x67F0	R/W	IVEIV_254	IV/EIV for WCID254	*
0x67F8	R/W	IVEIV_255	IV/EIV for WCID255 (not used)	*

WCID_AT: WCID Attribute Table (offset: 0x6800)

Offset	Type	Name	Description	Initial value
0x6800	R/W	WCID_ATTR_0	WCID Attribute for WCID0	*
0x6804	R/W	WCID_ATTR_1	WCID Attribute for WCID1	*
....	R/W	WCID Attribute for WCID2~253	*
0x6BF8	R/W	WCID_ATTR_254	WCID Attribute for WCID254	*
0x6BFC	R/W	WCID_ATTR_255	WCID Attribute for WCID255	*

SKT: Shared Key Table (offset: 0x6C00)

Offset	Type	Name	Description	Initial value
0x6C00	R/W	SKEY_0	Shared key for BSS_IDX=0, KEY_IDX=0	*
0x6C20	R/W	SKEY_1	Shared key for BSS_IDX=0, KEY_IDX=1	*
0x6C40	R/W	SKEY_2	Shared key for BSS_IDX=0, KEY_IDX=2	*

0x6C60	R/W	SKEY_3	Shared key for BSS_IDX=0, KEY_IDX=3	*
0x6C80	R/W	SKEY_4	Shared key for BSS_IDX=1, KEY_IDX=0	*
0x6CA0	R/W	SKEY_5	Shared key for BSS_IDX=1, KEY_IDX=1	*
0x6CC0	R/W	SKEY_6	Shared key for BSS_IDX=1, KEY_IDX=2	*
0x6CE0	R/W	SKEY_7	Shared key for BSS_IDX=1, KEY_IDX=3	*
0x6D00	R/W	SKEY_8	Shared key for BSS_IDX=2, KEY_IDX=0	*
0x6D20	R/W	SKEY_9	Shared key for BSS_IDX=2, KEY_IDX=1	*
0x6D40	R/W	SKEY_10	Shared key for BSS_IDX=2, KEY_IDX=2	*
0x6D60	R/W	SKEY_11	Shared key for BSS_IDX=2, KEY_IDX=3	*
0x6D80	R/W	SKEY_12	Shared key for BSS_IDX=3, KEY_IDX=0	*
0x6DA0	R/W	SKEY_13	Shared key for BSS_IDX=3, KEY_IDX=1	*
0x6DC0	R/W	SKEY_14	Shared key for BSS_IDX=3, KEY_IDX=2	*
0x6DE0	R/W	SKEY_15	Shared key for BSS_IDX=3, KEY_IDX=3	*
0x6E00	R/W	SKEY_16	Shared key for BSS_IDX=4, KEY_IDX=0	*
0x6E20	R/W	SKEY_17	Shared key for BSS_IDX=4, KEY_IDX=1	*
0x6E40	R/W	SKEY_18	Shared key for BSS_IDX=4, KEY_IDX=2	*
0x6E60	R/W	SKEY_19	Shared key for BSS_IDX=4, KEY_IDX=3	*
0x6E80	R/W	SKEY_20	Shared key for BSS_IDX=5, KEY_IDX=0	*
0x6EA0	R/W	SKEY_21	Shared key for BSS_IDX=5, KEY_IDX=1	*
0x6EC0	R/W	SKEY_22	Shared key for BSS_IDX=5, KEY_IDX=2	*
0x6EE0	R/W	SKEY_23	Shared key for BSS_IDX=5, KEY_IDX=3	*
0x6F00	R/W	SKEY_24	Shared key for BSS_IDX=6, KEY_IDX=0	*
0x6F20	R/W	SKEY_25	Shared key for BSS_IDX=6, KEY_IDX=1	*
0x6F40	R/W	SKEY_26	Shared key for BSS_IDX=6, KEY_IDX=2	*
0x6F60	R/W	SKEY_27	Shared key for BSS_IDX=6, KEY_IDX=3	*
0x6F80	R/W	SKEY_28	Shared key for BSS_IDX=7, KEY_IDX=0	*
0x6FA0	R/W	SKEY_29	Shared key for BSS_IDX=7, KEY_IDX=1	*
0x6FC0	R/W	SKEY_30	Shared key for BSS_IDX=7, KEY_IDX=2	*
0x6FE0	R/W	SKEY_31	Shared key for BSS_IDX=7, KEY_IDX=3	*

SKM: Shared Key Mode (offset: 0x7000)

Offset	Type	Name	Description	Initial value
0x7000	R/W	SKEY_MODE_0_7	Shared mode for SKEY0-SKEY7	*
0x7004	R/W	SKEY_MODE_8_15	Shared mode for SKEY8-SKEY15	*
0x7008	R/W	SKEY_MODE_16_23	Shared mode for SKEY16-SKEY23	*
0x700C	R/W	SKEY_MODE_24_31	Shared mode for SKEY24-SKEY31	*

3.20.3.13 Descriptor and Wireless information

3.20.3.13.1 TX frame information

To transmit a frame, the driver needs to prepare the TX frame information for hardware. The TX frame information contains the transmission control, the header, and the payload. The transmission control information (the “**TXWI**”) is used by the MAC and BBP and is applied for the associated TX frame when transmission. The header and payload is the content of an 802.11 packet. The TX information could be scattered in several segments. The TX descriptor (the “**TXD**”) specifies the location and length of the TX frame information segment. TX frame information could be linked by use of several TXD. These TXD are arranged in a TXD ring in serial. Below diagram illustrates the linking between TXD and TX frame information.

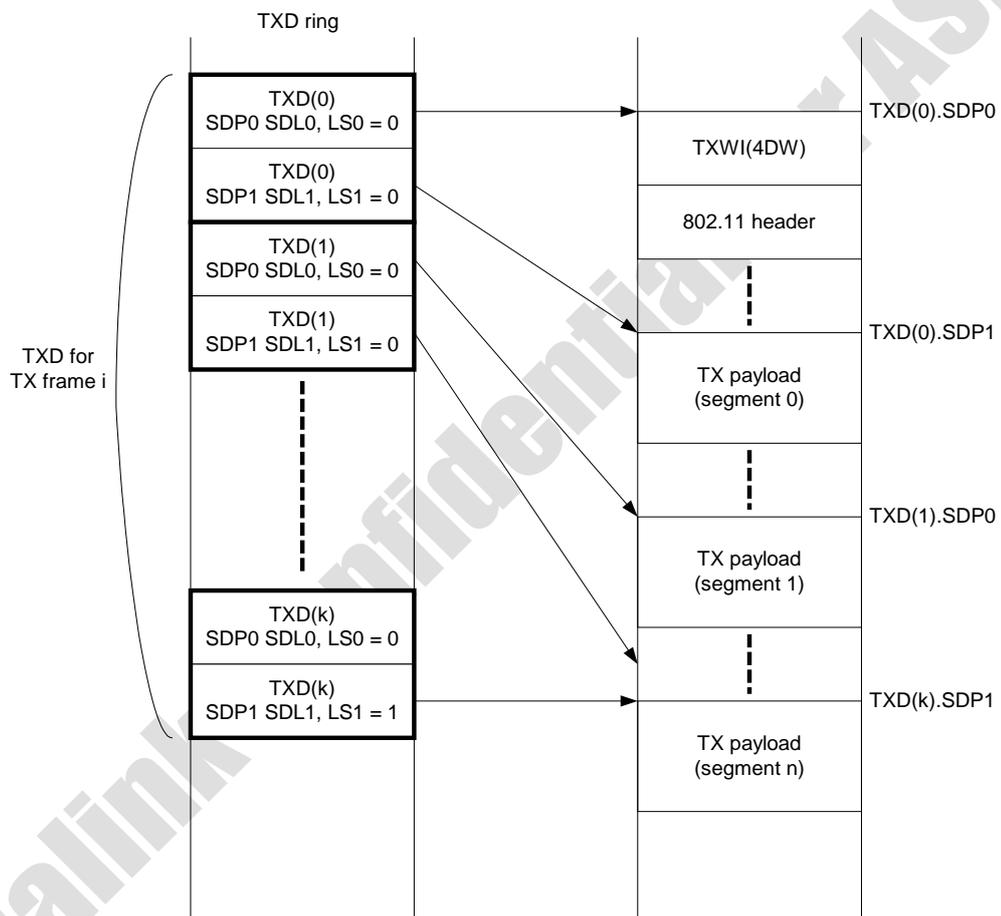

Fig. 3-20-3 TX frame Information

3.20.3.13.2 TX descriptor format

Fig. 3-20-4 TX Descriptor Format

- ◆ **SDP0**: Segment Data Pointer 0
- ◆ **SDL0**: Segment Data Length for the data pointed by SDP0.
- ◆ **SDP1**: Segment Data Pointer 1.
- ◆ **SDL1**: Segment Data Length for the data pointed by SDP1.
- ◆ **LS0**: data pointed by SDP0 is the last segment
- ◆ **LS1**: data pointed by SDP1 is the last segment
- ◆ **DDONE**: DMA Done. DMA has transferred the segments pointed by this TX descriptor

3.20.3.13.3 TXWI format

Fig. 3-20-5 TXWI Format

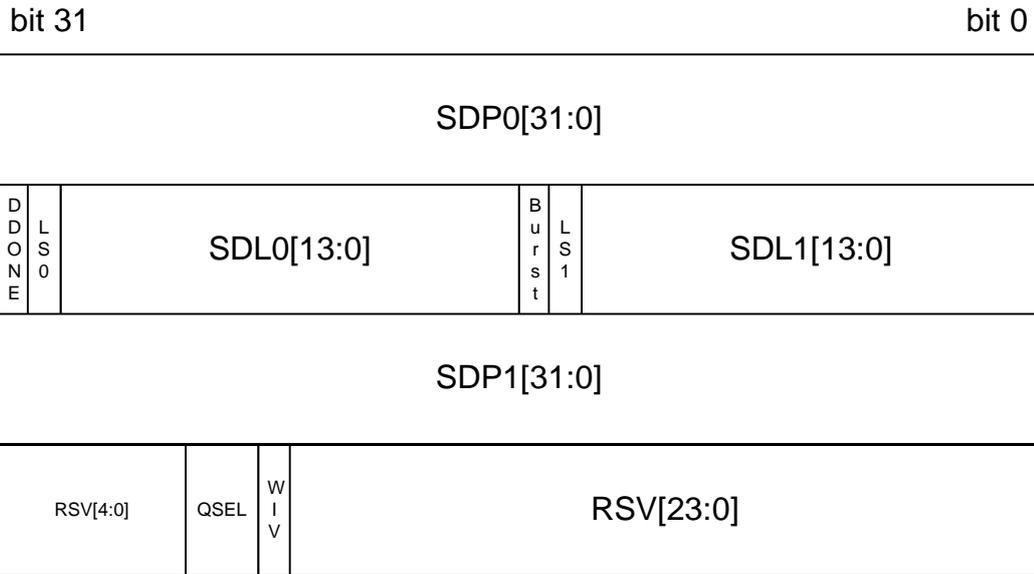
- **FRAG**: 1: to inform TKIP engine this is a fragment, so that TKIP MIC is appended by driver at the last fragment; hardware TKIP engine only need to insert IV/EIV and ICV
- **MMPS**: 1: the remote peer is in dynamic MIMO-PS mode

- **CFAIL:** 1: if an ACK is required to the same peer as this outgoing DATA frame, then MAC TX will send a single DATA+CFAIL frame instead of separate ACK and DATA frames. 0: no piggyback ACK allowed for the RA of this frame.
- **TS:** 1: This is a BEACON or ProbeResponse frame and MAC needs to auto insert 8-byte timestamp after 802.11 WLAN header.
- **AMPDU:** this frame is eligible for AMPDU. MAC TX will aggregate subsequent outgoing frames having <same RA, same TID, AMPDU=1> whenever TXOP allows. Even there's only one DATA frame to be sent, as long as the AMPDU bit in TXWI is ON, MAC will still package it as AMPDU with implicit BAR. This adds only 4-byte AMPDU delimiter overhead into the outgoing frame and implies the response frame is a BA instead of ACK. NOTE: driver should set AMPDU=1 only after a BA session is successfully negotiated, because Block ACK is the only way to acknowledge in AMPDU case.
- **MPDU density:** 1/4usec ~ 16usec per-peer parameter used in outgoing A-MPDU. (This field complies with the "minimum MDPDU Starting Spacing" of the A-MPDU parameter field of draft 1.08).
 - 000- no restriction
 - 001- 1/4 μ sec
 - 010- 1/2 μ sec
 - 011- 1 μ sec
 - 100- 2 μ sec
 - 101- 4 μ sec
 - 110- 8 μ sec
 - 111- 16 μ sec
- **TXOP: TX back off mode.** 0: HT TXOP rule; 1: PIFS TX; 2: SIFS (only when previous frame exchange is successful); 3: Back off.
- **"MCS/BW/ShortGI/OFDM/MIMO":** TX data rate & MIMO parameters for this outgoing frame to be filled into BBP.
- **ACK:** this bit informs MAC to wait for ACK or not after transmission of the frame. Even though QOD DATA frame has ACK policy in its QOS CONTROL field, MAC TX solely depends on this ACK bit to decide waiting of ACK or not.
- **NSEQ:** 1: to use the special h/w SEQ number register in MAC block.
- **BA window size:** tell MAC the maximum number of to-be-BAed frames is allowed of the RA (RA's BA re-ordering buffer size)
- **WCID (Wireless Client Index):** lookup result of ADDR1 in the peer table (255=not found). This index is also used to find all the attributes of the wireless peer (e.g. TX rate, TX power, pair-wise KEY, IV, EIV,). This index has consistent meaning in both driver and hardware.
- **MSDU total byte count:** total length of this frame.
- **Packet ID:** as a cookie specified by driver and will be latched into the TX result register stack. Driver use this field to identify special frame's TX result.
- **IV:** used by encryption engine.
- **EIV:** used by encryption engine.

3.20.3.13.4 RX descriptor ring

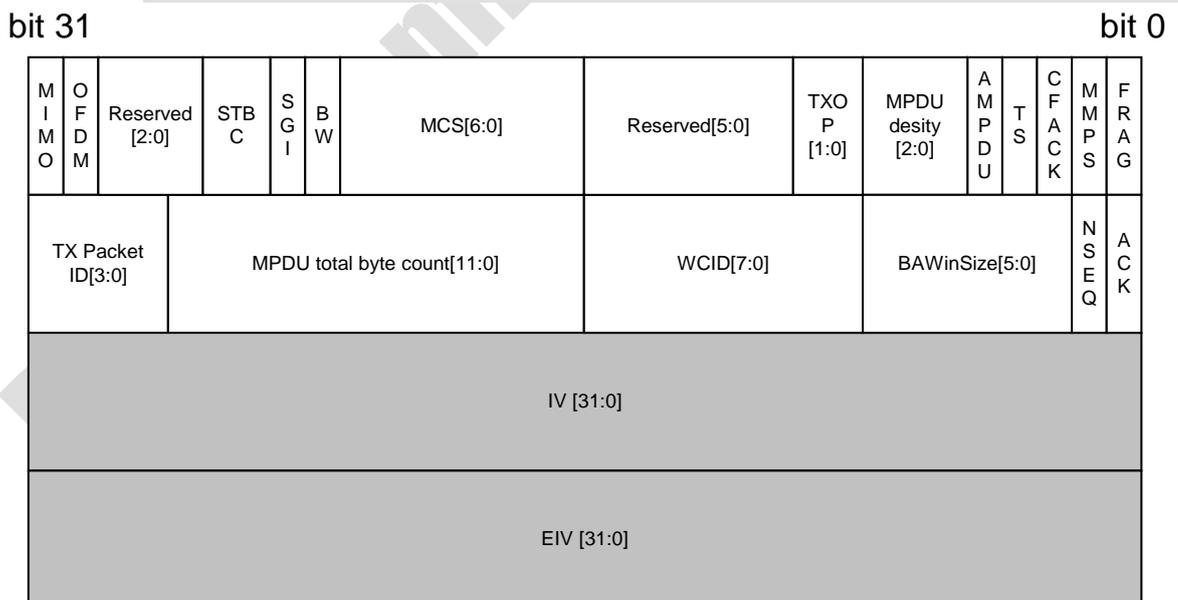
The RX descriptor (the “*RXD*”) specifies the location to place the payload of the received frame (the RX payload) and the associated receiving information (the “*RXWI*”). One RXD serves for one receiving frame. Only SDP0 and SDL0 are useful in the RXD. The RXD is arranged in the RXD ring in serial. The hardware links the RXWI and RX payload in serial and place it to the location specified in SDP0. See below diagram.

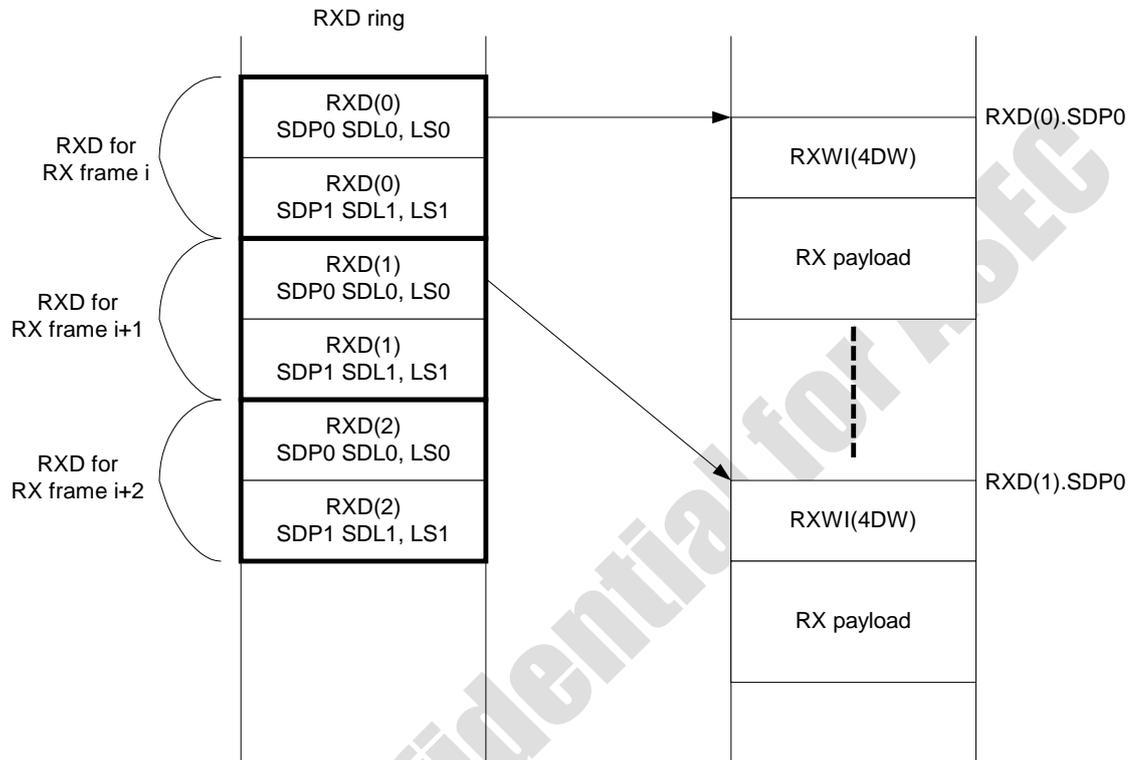

Fig. 3-20-6 RX Descriptor Ring

3.20.3.13.5 RX descriptor format

Fig. 3-20-7 RX Descriptor Format

Following fields are driver-specified.

- ◆ **SDP0**: Segment Data Pointer 0.
- ◆ **SDL0**: Segment Data Length for the data pointed by SDP0.
- ◆ **SDP1**: Segment Data Pointer 1.
- ◆ **SDL1**: Segment Data Length for the data pointed by SDP1.
- ◆ **DDONE**: DMA Done. DMA has moved the RX frame to the specified location. Set by hardware and cleared by driver.

Following fields are filled by hardware.

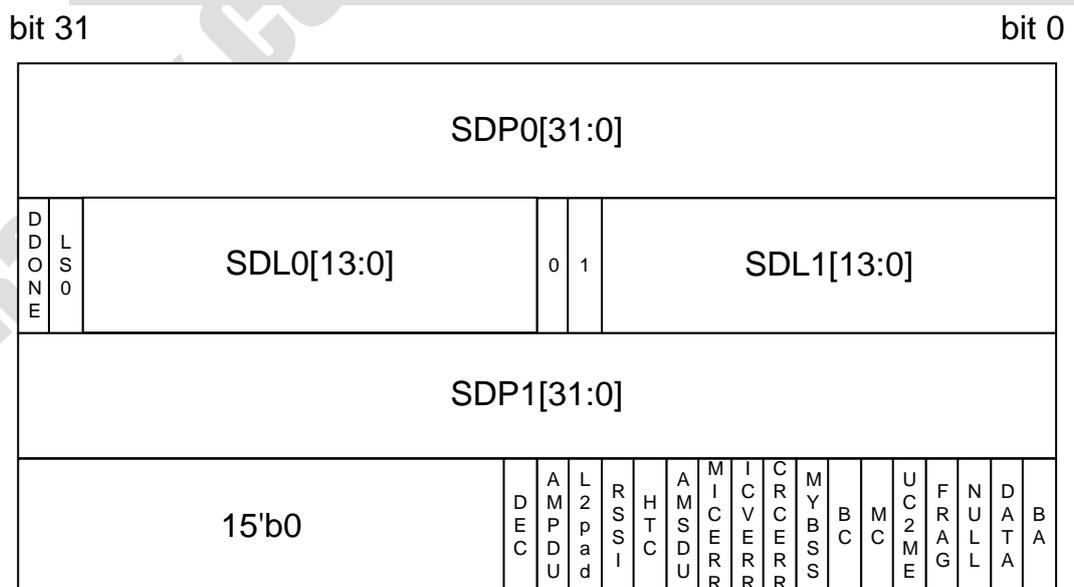
- ◆ **BA**: the received frame is part of BA session, need to do re-ordering.
- ◆ **DATA**: 1: the received frame is DATA type.
- ◆ **NULL**: 1: the received frame has sub-type NULL/QOS-NULL.
- ◆ **FRAG**: 1: the receive frame is a fragment
- ◆ **UC2ME**: 1: the received frame ADDR1 = my MAC address
- ◆ **MC**: 1: the received frame ADDR1 = multicast
- ◆ **BC**: 1: the received frame ADDR1 = ff:ff:ff:ff:ff:ff
- ◆ **MyBSS**: 1: the received frame BSSID is one of my BSS (as an AP, max 4 BSSID supported)
- ◆ **CRC error**: 1: the received frame is CRC error
- ◆ **ICV error**: 1: the received frame is ICV error
- ◆ **MIC error**: 1: the received frame is MIC error (RX CNRL register should support individual pass-up error frame to driver in order to implement MIC error detection feature)
- ◆ **AMSDU**: the received frame is in A-MSDU sub frame format which is <802.3 + MSDU + padding>
- ◆ **HTC**: 1: this received frame came with HTC field, 0: no HTC field
- ◆ **RSSI**: 1: RSSI information available in RSSI0, RSSI1, RSSI2 fields
- ◆ **L2Pad**: 1: the L2 header is recognizable and been 2-byte-padded to ensure payload to align at 4-byte boundary. 0: L2 header not extra padded
- ◆ **AMPDU**: 1: this is an AMPDU segregated frame
- ◆ **DEC**: 1: this is a decrypted frame

3.20.3.13.6 RXWI format

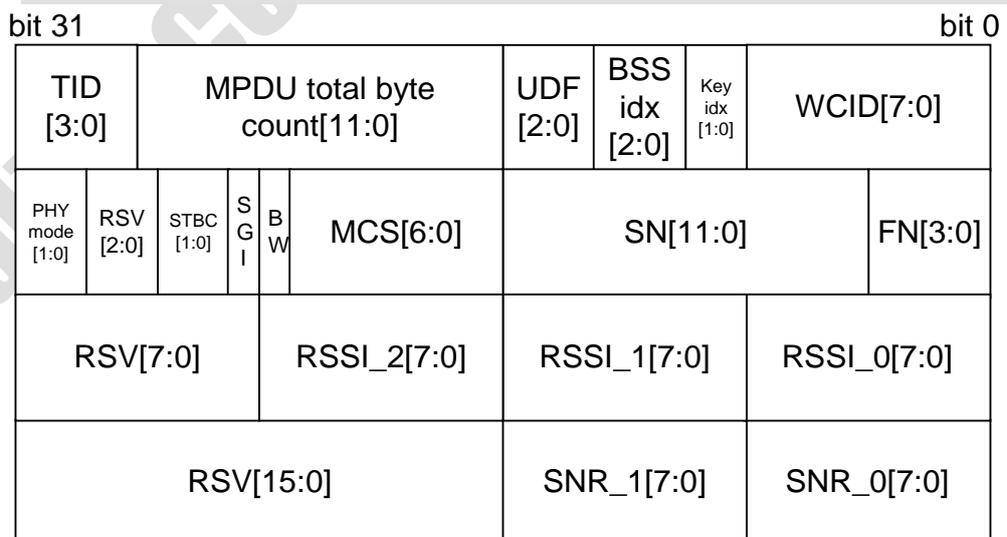

Fig. 3-20-8 RXWI Format

- ◆ **WCID**: index of ADDR2 in the pair wise KEY table. This value uniquely identifies the TA. WCID=255 means not found.
- ◆ **KEY Index**: 0~3 extracted from IV field. For driver reference only, no particular usage so far.
- ◆ **BSSID index**: 0~7 for BSSID0~7. Extract from 802.11 header (the last three bits of BSSID field)
- ◆ **UDF**: User Defined Field.
- ◆ **MPDU total byte count**: the entire MPDU length.
- ◆ **TID**: extracted from 8002.11 QOS control field.
- ◆ **FN**: fragment number of the received MPDU. Extract from 802.11 headers.
- ◆ **SN**: sequence number of the received MPDU. Used for BA re-ordering especially that AMSDU are auto segregated by hardware and lost the 802.11 header.
- ◆ **"MCS/BW/SGI/PHYmode"**: RX data rate & related MIMO parameters of this frame got from PLCP header. See next section for the detail.
- ◆ **RSSI0, RSSI1, and RSSI2**: BBP reported RSSI information of the received frame.
- ◆ **SNR0, SNR1**: BBP reported SNR information of the received frame.

3.20.3.13.7 Brief PHY rate format and definition

A 16-bit brief PHY rate is used in MAC hardware.

It is the same PHY rate field described in TXWI and RXWI.

Bit	Name	Description
15:14	PHY MODE	Preamble mode 0: Legacy CCK, 1: Legacy OFDM, 2: HT mix mode, 3: HT green field
13:11	-	Reserved
10:9	-	Reserved
8	SGI	Short Guard Interval, only support for HT mode 0: 800ns, 1: 400ns
7	BW	Bandwidth Support both legacy and HT modes 40Mhz in legacy mode means duplicate legacy 0: 20Mhz, 1: 40Mhz
6:0	MCS	Modulation Coding Scheme

Table. Brief PHY rate format

MODE = Legacy CCK	
MCS = 0	Long Preamble CCK 1Mbps
MCS = 1	Long Preamble CCK 2Mbps
MCS = 2	Long Preamble CCK 5.5Mbps
MCS = 3	Long Preamble CCK 11Mbps
MCS = 8	Short Preamble CCK 1Mbps * illegal rate
MCS = 9	Short Preamble CCK 2Mbps
MCS = 10	Short Preamble 5.5Mbps
MCS = 11	Short Preamble 11Mbps
Other MCS codes are reserved in legacy CCK mode. BW and SGI are reserved in legacy CCK mode.	
MODE = Legacy OFDM	
MCS = 0	6Mbps
MCS = 1	9Mbps
MCS = 2	12Mbps

MCS = 3	18Mbps
MCS = 4	24Mbps
MCS = 5	36Mbps
MCS = 6	48Mbps
MCS = 7	54Mbps
Other MCS code in legacy CCK mode are reserved	
When BW = 1, duplicate legacy OFDM is sent.	
SGI is reserved in legacy OFDM mode.	
MODE = HT mix mode / HT green field	
MCS = 0 (1S)	(BW=0, SGI=0) 6.5Mbps
MCS = 1	(BW=0, SGI=0) 13Mbps
MCS = 2	(BW=0, SGI=0) 19.5Mbps
MCS = 3	(BW=0, SGI=0) 26Mbps
MCS = 4	(BW=0, SGI=0) 39Mbps
MCS = 5	(BW=0, SGI=0) 52Mbps
MCS = 6	(BW=0, SGI=0) 58.5Mbps
MCS = 7	(BW=0, SGI=0) 65Mbps
MCS = 8 (2S)	(BW=0, SGI=0) 13Mbps
MCS = 9	(BW=0, SGI=0) 26Mbps
MCS = 10	(BW=0, SGI=0) 39Mbps
MCS = 11	(BW=0, SGI=0) 52Mbps
MCS = 12	(BW=0, SGI=0) 78Mbps
MCS = 13	(BW=0, SGI=0) 104Mbps
MCS = 14	(BW=0, SGI=0) 117Mbps
MCS = 15	(BW=0, SGI=0) 130Mbps
MCS = 32	(BW=1, SGI=0) HT duplicate 6Mbps
When BW=1, PHY_RATE = PHY_RATE * 2	
When SGI=1, PHY_RATE = PHY_RATE * 10/9	
The effects of BW and SGI are accumulative.	
When MCS=0~7(1S), SGI option is supported. BW option is supported.	
When MCS=8~15(2S), SGI option is supported. BW option is supported.	
When MCS=32, only SGI option is supported. BW option is not supported. (BW =1)	
Other MCS code in HT mode are reserved	

3.20.3.14 Driver implementation note

3.20.3.14.1 instructions of down load 8051 firmware

1. Select on-chip program memory
 - i. SYS_CTRL.HST_PM_SEL (0x0400.bit[16]) =1
2. Write firmware into program memory space, which starts at 0x2000.
3. Close on-chip program memory.
 - i. SYS_CTRL.HST_PM_SEL (0x0400.bit[16]) =0
4. 8051 starts

3.20.3.14.2 Instruction of initialize DMA

1. Set base addresses and total number of descriptors:
 - i. TX_BASE_PTR0~TX_BASE_PTR5
 - ii. RX_BASE_PTR
 - iii. TX_MAX_CNT0~TX_MAX_CNT
 - iv. RX_MAX_CNT
2. Set WMM parameters
 - i. WMM_AIFSN_CFG
 - ii. WMM_CWMIN_CFG
 - iii. WMM_CWMAX_CFG
 - iv. WMM_TXOP0_CFG and WMM_TXOP1_CFG
3. Set DMA global configuration except TX_DMA_EN and RX_DMA_EN bits:
 - i. WPDMA_GLO_CFG
4. Set interrupt configuration:
 - i. DELAY_INT_CFG
5. Enable DMA interrupt:
 - i. INT_MASK
6. Enable DMA:
 - i. WPDMA_GLO_CFG.TX_DMA_EN = 1
 - WPDMA_GLO_CFG.RX_DMA_EN = 1

3.20.3.14.3 Instruction of clock control

3.20.3.14.3.1 Clock turn-off sequence

1. Switch 80MHz main clock to PLL clock:
 - i. Set SYS_CTRL.CLKSELECT = 1
2. Turn clock off:
 - i. Set SYS_CTRL.MAC_CLK_EN = 0
 - ii. Set SYS_CTRL.DMA_CLK_EN = 0
3. Turn off PLL:
 - i. Set PWR_PIN_CFG.IO_PLL_PD = 1.

3.20.3.14.3.2 Clock turn-on sequence

1. Turn on PLL:
 - i. Set PWR_PIN_CFG.IO_PLL_PD = 0
2. Waiting at least \$bbp_pll_ready for PLL clock stable:
3. Turn on clock:
 - i. Set SYS_CTRL.MAC_CLK_EN = 1
 - ii. Set SYS_CTRL.DMA_CLK_EN = 1

3.20.3.14.4 Instruction of TX/RX control

3.20.3.14.4.1 Freeze TX and RX sequence

1. Disable DMA TX:
 - i. Set WPDMA_GLO_CFG..TX_DMA_EN = 0
2. Polling until DMA TX becomes idle and PBF TX queue becomes empty:
 - i. Polling WPDMA_GLO_CFG. TX_DMA_BUSY = 0
 - ii. Polling TXRXQ_STA.TX0Q_STA = 2, TXRXQ_STA.TX1Q_STA = 2, polling TXRXQ_STA.TX2Q_STA = 2.
 - iii. If the polling period > \$dma_tx_polling_timeout, abort power saving procedure.
3. Disable MAC TX and RX:
 - i. Set MAC_SYS_CTRL.MAC_RX_EN = 0
 - ii. MAC_SYS_CTRL.MAC_TX_EN = 0
4. Polling until MAC TX and RX is disabled:
 - i. Polling MAC_STATUS_REG. TX_STATUS = 0, MAC_STATUS_REG. RX_STATUS = 0
 - ii. If the polling period > \$mac_polling_timeout, abort power saving procedure.
5. Disable DMA RX:
 - i. Set WPDMA_GLO_CFG..RX_DMA_EN = 0.
6. Polling until both DMA RX becomes idle and PBF RX queue becomes empty:
 - i. Polling WPDMA_GLO_CFG. RX_DMA_BUSY = 0.
 - ii. Polling TXRXQ_STA.RX0Q_STA = 0x22.
 - iii. If the polling period > \$dma_rx_polling_timeout, abort power saving procedure.

3.20.3.14.4.2 Recover TX and RX sequence

1. Enable DMA TX and RX:
 - i. Set WPDMA_GLO_CFG..RX_DMA_EN = 1
 - ii. Set WPDMA_GLO_CFG..TX_DMA_EN = 1
2. Enable MAC TX and RX:
 - i. Set MAC_SYS_CTRL.MAC_RX_EN = 1
 - ii. Set MAC_SYS_CTRL.MAC_TX_EN = 1

3.20.3.14.5 Instruction of RF power on/off sequence

1. Power down RF components sequence
 - i. Power down RF component
2. Set PWR_PIN_CFG.IO_ADDA_PD = 1.
3. Set PWR_PIN_CFG.IO_RF_PE = 0.
4. Set TX_PIN_CFG.TRSW_EN = 0.
5. Set TX_PIN_CFG.RFTR_EN = 0.
6. Set TX_PIN_CFG.LNA_PE*EN = 0.
7. Set TX_PIN_CFG.PA_PE*EN = 0.
8. Enable RF components sequence
 - i. Recover the registers in previous sequence.
 - ii. Wait \$rf_pll_ready for RF PLL becomes stable.

3.20.3.14.6 Power saving procedure

1. Freeze TX and RX
2. Power down LED and RF components
3. Clock turn-off

3.20.3.14.7 Power recovery procedure

1. Clock turn-on
2. Enable LED and RF components
3. Recover TX and RX

3.20.3.14.8 Parameters

1. \$rf_pll_ready = TBD.
2. \$bbp_pll_ready = 500 us.
3. \$dma_rx_polling_timeout = TBD.
4. \$dma_tx_polling_timeout = TBD.
5. \$mac_polling_timeout = TBD.

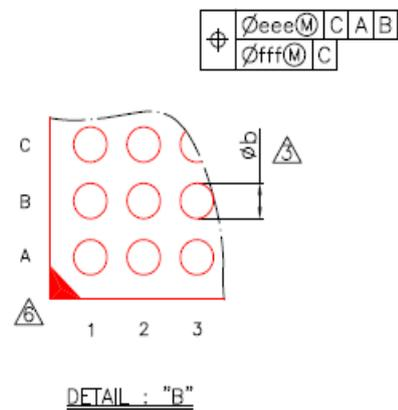
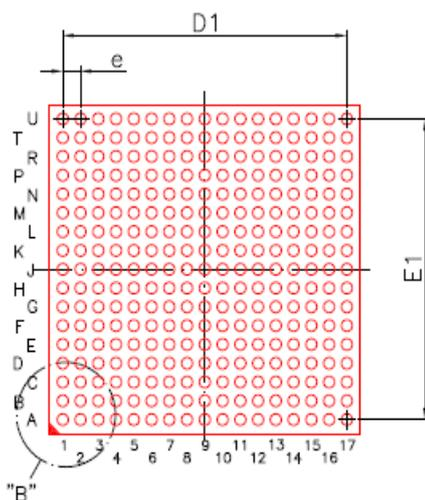
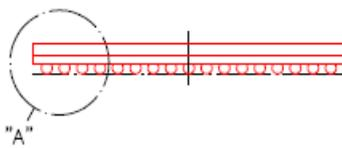
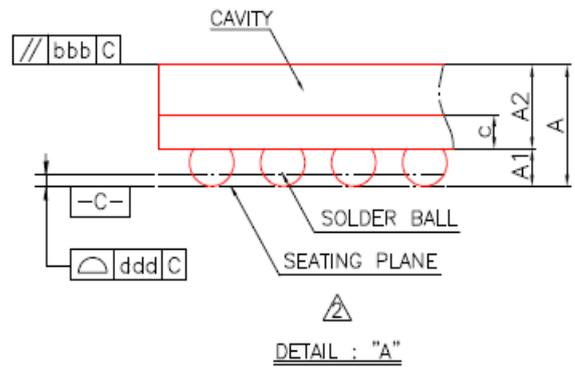
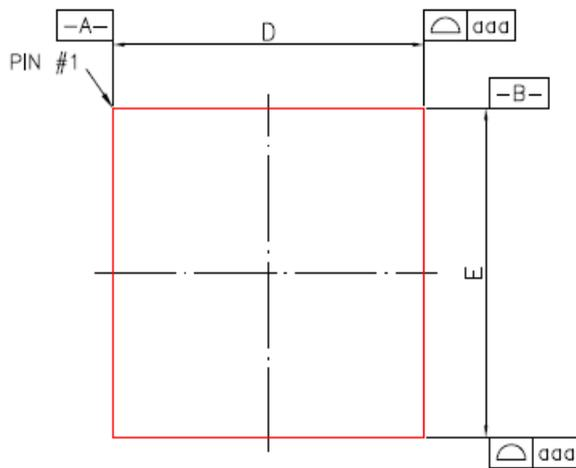
4 Package Physical Dimension TFBGA 289B (14x14x1.4mm)

Symbol	Dimension in mm			Dimension in inch		
	MIN	NOM	MAX	MIN	NOM	MAX
A	---	---	1.40	---	---	0.055
A1	0.35	0.40	0.45	0.014	0.016	0.018
A2	0.84	0.89	0.94	0.033	0.035	0.037
c	0.32	0.36	0.40	0.013	0.014	0.016
D	13.90	14.00	14.10	0.547	0.551	0.555
E	13.90	14.00	14.10	0.547	0.551	0.555
D1	---	12.80	---	---	0.504	---
E1	---	12.80	---	---	0.504	---
e	---	0.80	---	---	0.031	---
b	0.45	0.50	0.55	0.018	0.020	0.022
aaa	0.15			0.006		
bbb	0.20			0.008		
ddd	0.20			0.008		
eee	0.15			0.006		
fff	0.08			0.003		
MD/ME	17/17			17/17		

NOTE :

1. CONTROLLING DIMENSION : MILLIMETER.
- △ PRIMARY DATUM C AND SEATING PLANE ARE DEFINED BY THE SPHERICAL CROWNS OF THE SOLDER BALLS.
- △ DIMENSION b IS MEASURED AT THE MAXIMUM SOLDER BALL DIAMETER, PARALLEL TO PRIMARY DATUM C.
4. THERE SHALL BE A MINIMUM CLEARANCE OF 0.25mm BETWEEN THE EDGE OF THE SOLDER BALL AND THE BODY EDGE.
5. REFERENCE DOCUMENT : JEDEC MO-205.
- △ THE PATTERN OF PIN 1 FIDUCIAL IS FOR REFERENCE ONLY.
7. SPECIAL CHARACTERISTICS C CLASS: bbb, ddd

5 Revision History

Rev	Date	From	Description
2.0	2008/8/14	Frank Lu	Initial Release
2.1	2009/4/15	Frank Lu	<ol style="list-style-type: none"> 1. Revise 3.9.1 Feature 2. Add 3.18.5 Flow control settings 3. Add 3.18.6 VID and VLAN member set 4. Add Table 3-19-3 Parameter value in 3.19.3 5. Add TFBGA 314B (16×16×0.94mm) package 6. Update GPIO pin definition 7. Update 2.Maximum Ratings and Operating 8. Revise SGC2: Switch Global Control 2 (offset: 0xE4) 9. Update Fig. 3-17-4 PDMA RX Descriptor Format 10. Revise MA21 of Boot strapping Signal description 11. Revise the descriptions of related LDO 12. Revise 3.17.3.2 GDMA_FWD_CFG
2.2	2009/8/6	Frank Lu	<ol style="list-style-type: none"> 1. Revise 2.6.1 SDRAM Interface 2. Revise 3.16.3 CTRL: NAND Flash Control Register (offset: 0x00). 3. Update figure (3-18-3)
2.3	2009/10/15	James Hu Frank Lu John Chang	<ol style="list-style-type: none"> 1. Remove "GMAC" in page 1 2. Remove "note 2 describe" in page 10 3. Change RGMII_GPIO_MODE in page 25 4. Modify 2.5.1DC characteristics for GPIO pins operated @3.3v 5. Revise 3.18.3 - Register Description (base: 0x1011.0000) 6. Modify 2.5 DC Electrical Characteristics from 1.2V Supply Voltage to 1.5 V Supply Voltage (Vcc12 to Vcc15) 7. Modify 2.5 DC Electrical Characteristics from 1.2V Current consumption to 1.5V Current consumption (Icc12 to Icc15) 8. Modify 2.2 thermal information

This product is not designed for use in medical, life support applications. Do not use this product in these types of equipments or applications. This document is subject to change without notice and Ralink assumes no responsibility for any inaccuracies that may be contained in this document. Ralink reserves the right to make change in the products to improve function, performance, reliability, and to attempt to supply the best product possible.

Ralink Confidential for ASEC