



TO-251 Plastic-Encapsulate Transistors

**13003** TRANSISTOR (NPN)

**FEATURE**

- power switching applications

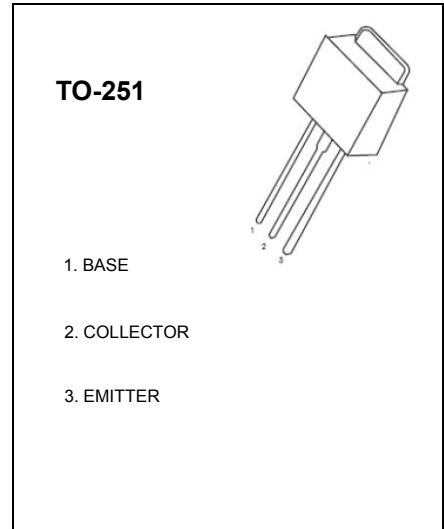

**MAXIMUM RATINGS(T<sub>a</sub>=25°C unless otherwise noted)**

Symbol	Parameter	Value	Unit
V <sub>CB0</sub>	Collector -Base Voltage	700	V
V <sub>CEO</sub>	Collector-Emitter Voltage	400	V
V <sub>EBO</sub>	Emitter-Base Voltage	9	V
I <sub>C</sub>	Collector Current -Continuous	1.2	A
P <sub>C</sub>	Total Power Dissipation	20	W
T <sub>J</sub>	Junction Temperature	150	°C
T <sub>stg</sub>	Storage Temperature	-55~150	°C

**ELECTRICAL CHARACTERISTICS (T<sub>a</sub>=25°C unless otherwise specified)**

Parameter	Symbol	Test conditions	Min	Typ	Max	Unit
Collector-base breakdown voltage	V <sub>(BR)CB0</sub>	I <sub>C</sub> = 100μA, I <sub>E</sub> =0	700			V
Collector-emitter breakdown voltage	V <sub>(BR)CEO</sub>	I <sub>C</sub> = 1mA, I <sub>B</sub> =0	400			V
Emitter-base breakdown voltage	V <sub>(BR)EBO</sub>	I <sub>E</sub> = 100μA, I <sub>C</sub> =0	9			V
Collector cut-off current	I <sub>CB0</sub>	V <sub>CB</sub> = 600V, I <sub>E</sub> =0			100	μA
	I <sub>CEO</sub>	V <sub>CB</sub> = 400V, I <sub>E</sub> =0			100	μA
Emitter cut-off current	I <sub>EBO</sub>	V <sub>EB</sub> = 7V, I <sub>C</sub> =0			100	μA
Dc current gain	h <sub>FE1</sub>	V <sub>CE</sub> = 10 V, I <sub>C</sub> = 200mA	9		40	
	h <sub>FE2</sub>	V <sub>CE</sub> = 10 V, I <sub>C</sub> = 0.25mA	5			
Collector-emitter saturation voltage	V <sub>CE(sat)</sub>	I <sub>C</sub> =200mA, I <sub>B</sub> = 40mA			0.5	V
Base-emitter saturation voltage	V <sub>BE(sat)</sub>	I <sub>C</sub> =200mA, I <sub>B</sub> = 40mA			1.1	V
Transition frequency	f <sub>T</sub>	V <sub>CE</sub> =10V, I <sub>C</sub> =100mA f =1MHz	5			MHz
Fall time	t <sub>f</sub>	I <sub>C</sub> =1A, I <sub>B1</sub> =-I <sub>B2</sub> =0.2A V <sub>CC</sub> =100V			0.5	μs
Storage time	t <sub>s</sub>				2.5	μs

**CLASSIFICATION OF h<sub>FE1</sub>**

Range	9-15	15-20	20-25	25-30	30-35	35-40