



KTA1023 TRANSISTOR (PNP)

FEATURES

Complementary to KTC1027

MAXIMUM RATINGS (T_A=25°C unless otherwise noted)

Symbol	Parameter	Value	Units
V _{CBO}	Collector-Base Voltage	-120	V
V _{CEO}	Collector-Emitter Voltage	-120	V
V _{EBO}	Emitter-Base Voltage	-5	V
I _C	Collector Current -Continuous	-0.8	A
P _C	Collector Power Dissipation	1	W
T _J	Junction Temperature	150	°C
T _{stg}	Storage Temperature	-55to+150	°C

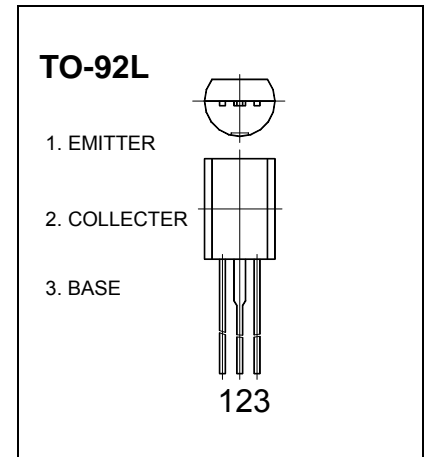

ELECTRICAL CHARACTERISTICS (T_{amb}=25°C unless otherwise specified)

Parameter	Symbol	Test conditions	MIN	TYP	MAX	UNIT
Collector-base breakdown voltage	V _{(BR)CBO}	I _C =-10μA, I _E =0	-120			V
Collector-emitter breakdown voltage	V _{(BR)CEO}	I _C =-10mA, I _B =0	-120			V
Emitter-Base breakdown voltage	V _{(BR)EBO}	I _E =-1mA, I _C =0	-5			V
Collector cut-off current	I _{CBO}	V _{CB} =-120V, I _E =0			-0.1	μ A
Emitter cut-off current	I _{EBO}	V _{EB} =-5V, I _C =0			-0.1	μ A
DC current gain	h _{FE}	V _{CE} =-5V, I _C =-100mA	80		240	
Collector-emitter saturation voltage	V _{CE(sat)}	I _C =-500mA, I _B =-50mA			-1.0	V
Base-emitter voltage	V _{BE}	I _C =-500mA, V _{CE} =-5V			-1.0	V
Transition frequency	f _T	V _{CE} =-5V, I _C =-100mA		120		MHz
Collector output capacitance	C _{ob}	V _{CE} =-10V, I _E =0, f=1MHz			40	pF

CLASSIFICATION OF h_{FE}

Rank	O	Y
Range	80-160	120-240