



给您一颗快乐的“芯”！

# DIP Seam Tuning Fork 2.0x6.0 mm YT-26 Series



## Features

- Tuning fork crystal in 2 x 6 mm cylinder type
- 32.768 KHz standard
- ±20 ppm Standard
- Excellent Reliability Performance



## Electrical Specifications

Item / Type	YT-26
Frequency Range	32.768KHz
Vibration Mode	AT Fundamental
Load Capacitance	12.5pF , or specify
Frequency Stability Overall	± 20 ppm, or specify
Frequency Tolerance (at 25 °C)	± 10 ppm, ± 20 ppm, or specify
Operating Temperature Range	-20 ~ +70 °C, or specify
Storage Temperature Range	-40~+85 °C , or specify
Shunt Capacitance (C0)	1.6pF Max.
Aging (at 25 °C)	± 3 ppm / year Max.
Drive Level	1 ~ 100 μ W ( 1.0 μ W Tvp )
Insulation Resistance	More Than 500MΩ at DC 100V

## Equivalent Series Resistance(ESR)

### Fundamental

32.768 KHz | 40 Ω Max.

## Dimensions

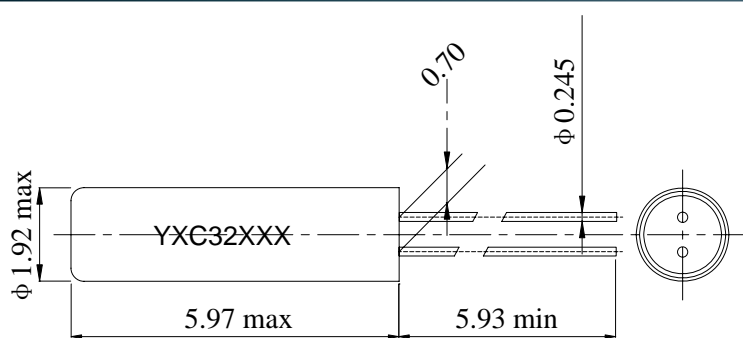

Units: mm(±0.1mm)

### ● Mounting of cylinder type products:

Soldering the body of the cylinder type crystal units with PCB must be avoided due to deteriorate the characteristics or damage the products. Rubber adhesive is recommended.

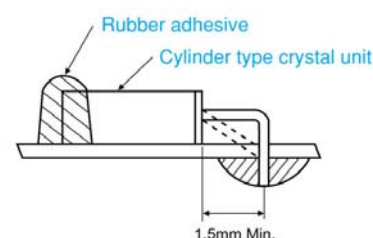

### ● Soldering

Lead wires should be soldered within 3 seconds with the soldering iron heated to a temperature no higher than 300°C

给您一颗快乐的“芯”！

★ PART NUMBER GUIDE 部件号示例 e.g. X206032768KGD2SC YT-26=1.92×5.97 DIP SEAM TYPE

Quartz Crystal Resonator	Dimensions	Frequency (Hz)	Load Capacitance (Pf)	Frequency Stability Overall (ppm)	Pin	Material	Operating Temp. Range
X	2060	32768K	G	D	2	S	C

Definition	Description
Operating Temperature Range	C: -20~+70°C
	I: -40~+85°C

★ REFLOW SOLDERING PROFILE 回流焊特性

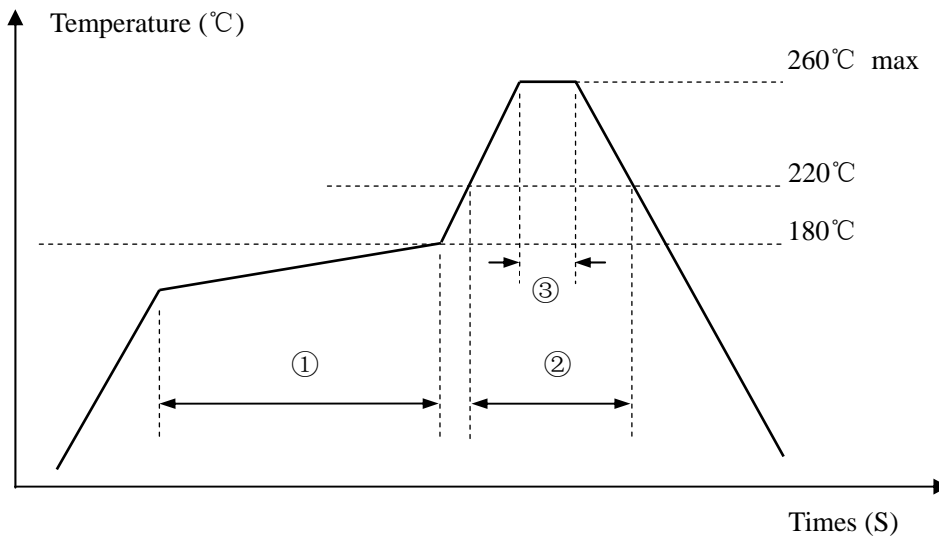

Pb free reflow A	①	Preheat	160~180°C	120sec. max
	②	Primary heat	220°C	60sec. max
	③	Peak	260°C	10sec. max.