

Feature

- Self adjust magnetic range
- High speed operation Frequency
- Zero speed detection
- No direction of rotation concern
- Short circuit protection
- RoHs Compliant 2011/65/EU

Application:

- Cam shaft sensing
- Gear tooth sensing

Product Description

The MT3601 is gear tooth sensor IC for use in automotive camshaft sensing. MT3601 is used with a bias magnet south facing the back (no mark) side of the IC. The technology used for the IC is Hall-effect based. The Chip incorporate Hall Effect plate, an A/D converter with self-calibrates the internal gain of the device to adjust the air-gap variations. And digital sample and hold circuit. , Schmitt trigger and an open drain output with short circuit protected.

As the gear tooth rotate, the chip samples an in increasing or decreasing flux density. When the flux has reached its minimum value and increased hysteresis flux, the output will turn on(BOP).When the flux has reached its maximum value and decreased hysteresis flux, the output will turn off(BRP).

The MT3601 is ideal for use in gather speed, position and direction detection to those gear-tooth based configurations. Particularly suited to those applications that require accurate duty cycle or accurate edge detection, such as automotive camshaft sensing.

Pin definition

Name	Number	Description
VDD	1	Power Supply
GND	2	Ground
OUT	3	Output Signal



Family members

Part Number	Description
MT3601A	Flat TO-92 package ,bulk packaging(1000pcs/bag)

The MT3601 is provided in a 3-pin Flat TO-92 that is Pb(lead) free with 100% matt tin plated leadframe

Block Diagram

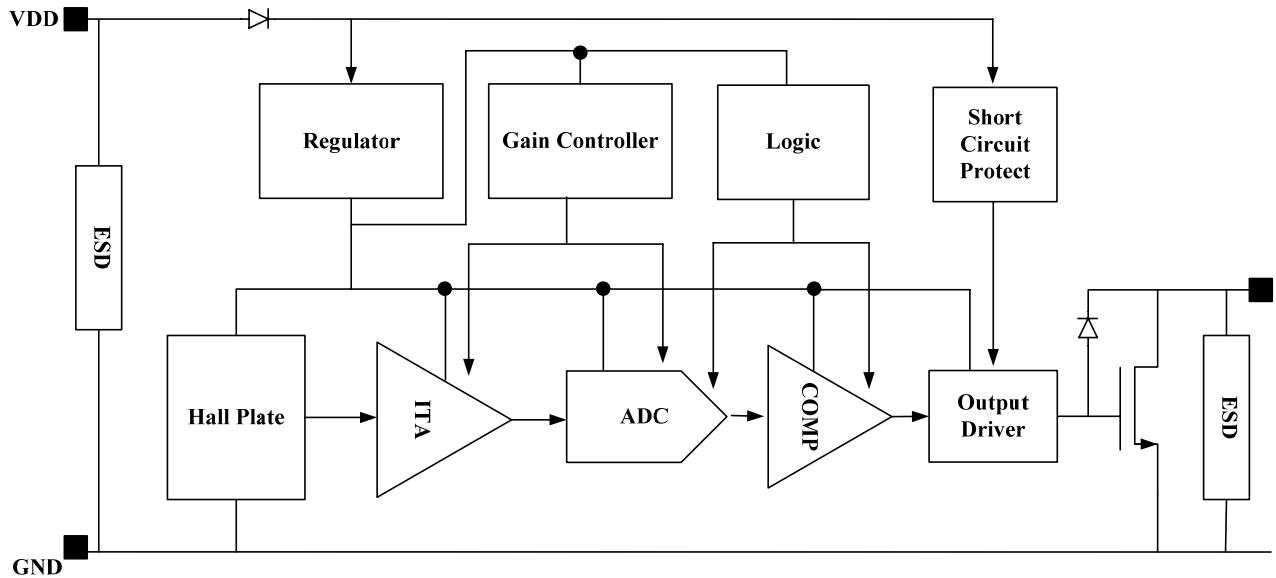

Electrical and Magnetic Characteristics

Absolute Maximum Rating

Absolute maximum ratings are limiting values to be applied individually, and beyond which the serviceability of the circuit may be impaired. Functional operability is not necessarily implied. Exposure to absolute maximum rating conditions for an extended period of time may affect device reliability.

Absolute maximum ratings: all voltages listed are referenced to GND

Symbol	Parameters	Min	Max	Unit
V _{DD}	Supply Voltage	-0.5	28	V
I _{OUT}	Continuous Output Current		40	mA
V _{out}	Output voltage	-0.5	28	V
T _A	Operating Temperature Range	-40	+150	°C
T _S	Storage Temperature Range	-65	+170	°C

Magnetic Characteristics

At T_A=-40°C to 150°C, V_{DD}=3.5V to 24V (Unless other specified)

Symbol	Parameters	Test Conditions	Min	Typ	Max	Units
B _{bias}	Back bias range		10		500	mT
B _{lin}	Linear region		50		400	mT
B _{hys}	Hysteresis window		2	4	6	mT

Note: 1mT=10Gauss.

Electrical Characteristics

At TA=-40°C to 150°C , V_{DD}=3.5V to 24V (Unless other specified)

Symbol	Parameters	Test Conditions	Min	Typ	Max	Units
V _{DD}	Supply voltage		3.5		24	V
I _{DD}	Supply current			3	6	mA
V _{son}	Output saturation voltage	I _{out} =25mA			0.4	V
I _{off}	Output leakage current	V _{out} =24V			10	uA
Tr	Output rise time	RL=1Kohm,CL=20pF			1.5	us
Tf	Output rise time	RL=1Kohm,CL=20pF			1.5	us
F _{sw}	Maximum switching frequency				20	KHz
I _{sh}	Output short circuit current		50	100	150	mA
T _{sh}	Output short circuit shutdown		50	100	150	us
R _{TH}	TO-92 package thermal resistance			230		°C/W

Device Evaluation Standard : EMC(Electromagnetic Compatibility)

Test name	Reference Specification
ESD-Human Body Model	JEDEC EIA /JESD22-A114F
ESD-Machine Model	JEDEC EIA /JESD22-A115
Conducted Transients	ISO 7637-1
Direct RF Injection	ISO11452-7
TEM Cell	ISO11452-3

Application Information

Application Circuit

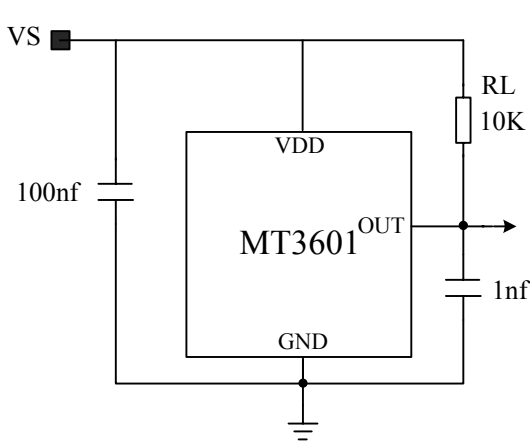

Typical application

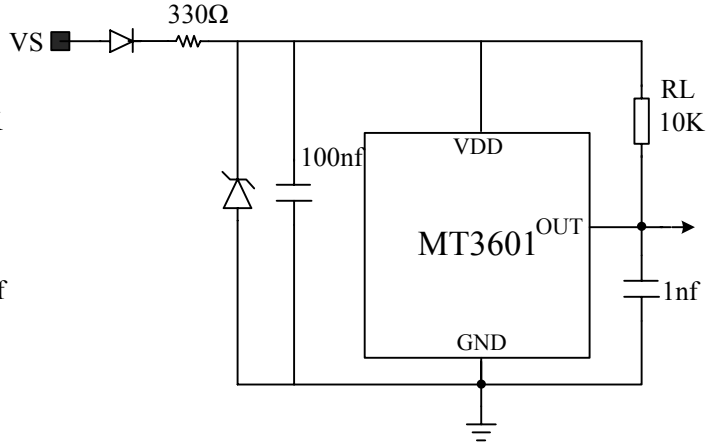

Harsh, noisy environments and automotive application

Configuration with Radial-Tooth

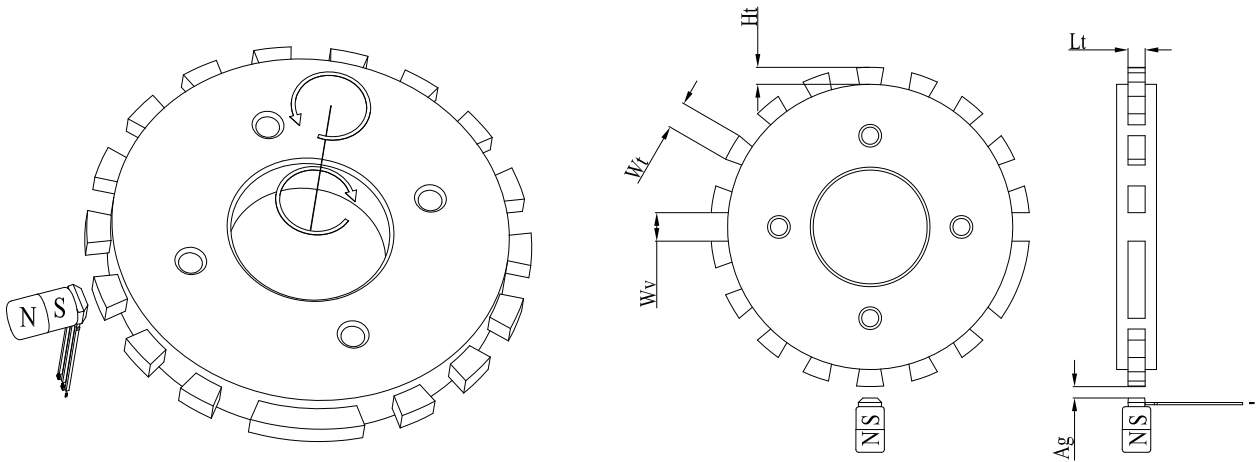

For the generation of adequate magnetic field level, the following recommendations should be followed in the design and specification of targets:

Symbol	Parameters	Min	Typ	Max	Units
AG	Distance of air gap	0.5		2.5	mm
Ht	Height of tooth	3.0			mm
Lt	Length of tooth	3.0			mm
Wt	Width of tooth	2.0			mm
Wv	Width of valley	2.0			mm
Material		Low carbon steel			

Operating Waveform

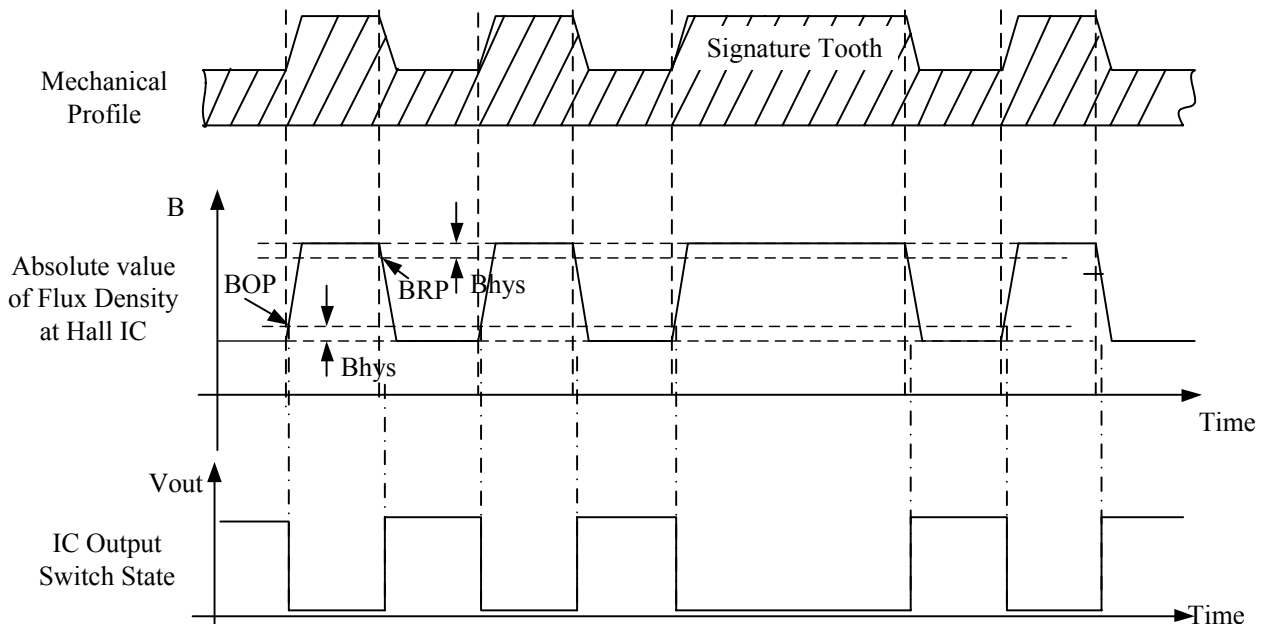

BOP: Operate point, switches the output ON(V_{out} =Low)

BRP: Release point, switches the output OFF(V_{out} =High)

Application Note:

Maximum dynamic range is 500 mT , linear dynamic range is 400mT , The hysteresis is fixed at 4mT, When the magnetic loop provides peak magnetic flux at the chip near the high end of the linear range of 400mT,best angular accuracy will be get.

The output is reset to the high level (output driver is off) at chip power on whatever the magnetic filed is. The output only changes after the first min is detected.

If the power supply of the chip is raised slowly, the reset state will be not stable,

The bias magnet must be glued to the back surface (unbranded side) of the IC, the south pole face the unbranded side of the device.

MT3601 Series

Hall Effect Cam Sensor IC



Package Designator

MT3601A

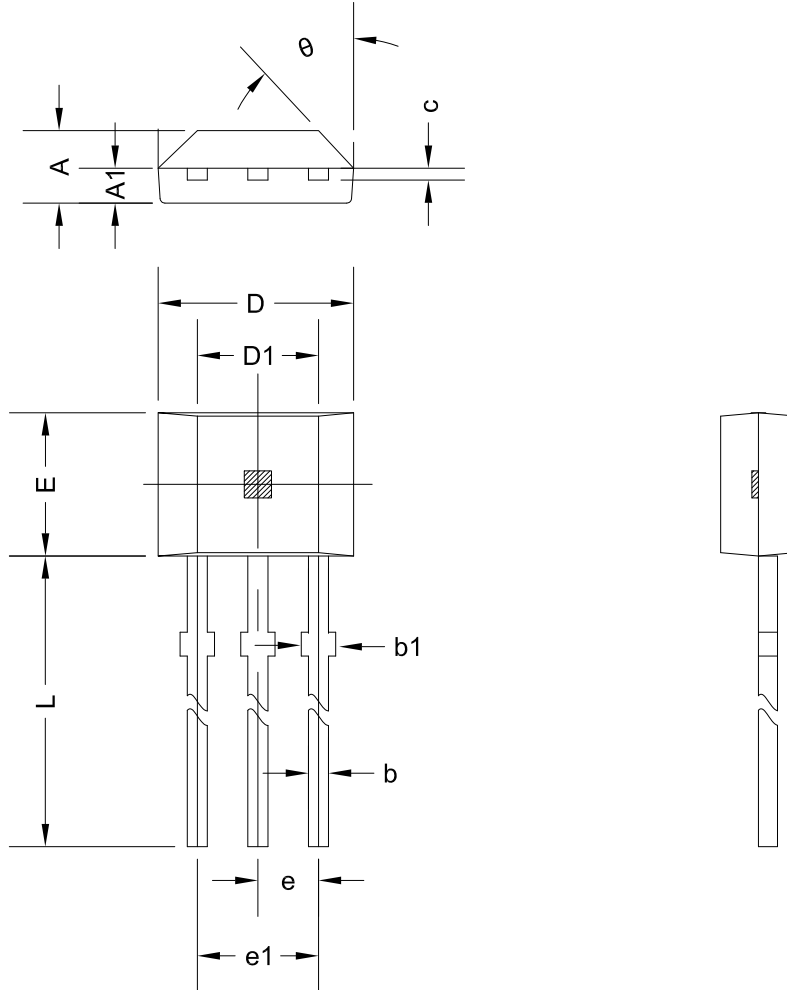

Symbol	Dimensions in Millimeters		Dimensions in Inches	
	Min	Max	Min	Max
A	1.42	1.62	0.056	0.064
A1	0.66	0.86	0.026	0.034
b	0.35	0.48	0.014	0.019
b1	0.4	0.55	0.016	0.022
c	0.36	0.51	0.014	0.020
D	3.9	4.2	0.154	0.165
D1	2.97	3.27	0.117	0.129
E	2.87	3.124	0.113	0.123
e	1.27 TYP		0.050 TYP	
e1	2.44	2.64	0.096	0.104
L	13.6	15.5	0.535	0.610
θ	45°TYP		45°TYP	