



78LXX

LINEAR INTEGRATED CIRCUIT

3-TERMINAL 0.1A POSITIVE VOLTAGE REGULATOR

DESCRIPTION

The UTC **78LXX** family is monolithic fixed voltage regulator integrated circuit. They are suitable for applications that required supply current up to 100mA.

FEATURES

- * Output current up to 100mA
- * Fixed output voltage of 5V, 6V, 8V, 9V, 10V, 12V, 15V, 18V and 24V available
- * Thermal overload shutdown protection
- * Short circuit current limiting

ORDERING INFORMATION

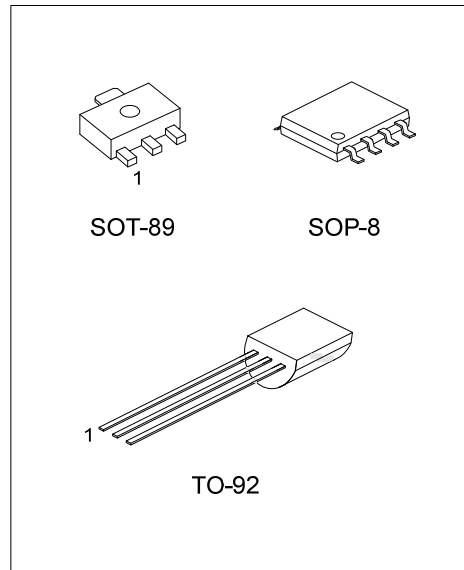

Ordering Number		Package	Pin Assignment								Packing
Lead Free	Halogen Free		1	2	3	4	5	6	7	8	
78LXXL-AB3-R	78LXXG-AB3-R	SOT-89	O	G	I	-	-	-	-	-	Tape Reel
78LXXL-S08-R	78LXXG-S08-R	SOP-8	O	G	G	N	N	G	G	I	Tape Reel
78LXXL-S08-R	78LXXG-S08-R	SOP-8	O	G	G	N	N	G	G	I	Tape Reel
78LXXL-T92-B	78LXXG-T92-B	TO-92	O	G	I	-	-	-	-	-	Tape Box
78LXXL-T92-K	78LXXG-T92-K	TO-92	O	G	I	-	-	-	-	-	Bulk
78LXXL-T92-R	78LXXG-T92-R	TO-92	O	G	I	-	-	-	-	-	Tape Reel

Note: 1. XX: Output Voltage, refer to Marking Information.

2. O: Output G: GND I: Input N: No Connection

<p>78LXXL-AB3-R</p> <p>(1)Packing Type (2)Package Type (3)Lead Free (4)Output Voltage Code</p>	<p>(1) B: Tape Box, K: Bulk, R: Tape Reel, T: Tube (2) AB3: SOT-89, S08: SOP-8, T92: TO-92 (3) G: Halogen Free, L: Lead Free (4) XX: refer to Marking Information</p>
--	---

MARKING INFORMATION

PACKAGE	VOLTAGE CODE	MARKING
SOP-8	05:5.0V 06:6.0V 08:8.0V 09:9.0V 10:10V 12:12V 15:15V 18:18V 24:24V	<p> UTC 78LXX Date Code Voltage Code L: Lead Free G: Halogen Free Lot Code </p>
SOT-89		<p> UTC 78LXX Date Code Voltage Code L: Lead Free G: Halogen Free </p>
TO-92		<p> UTC 78LXX Voltage Code L: Lead Free G: Halogen Free Date Code </p>

■ ABSOLUTE MAXIMUM RATINGS

PARAMETER		SYMBOL	RATINGS	UNIT
Input Voltage	$V_{OUT}=5\sim 9V$	V_{IN}	30	V
	$V_{OUT}=10\sim 18V$		35	
	$V_{OUT}=24V$		40	
Output Current		I_{OUT}	100	mA
Power Dissipation	SOP-8	P_D	300	mW
	TO-92		625	mW
	SOT-89		350	mW
Junction Temperature		T_J	+150	°C
Operating Temperature		T_{OPR}	-40~+85	°C
Storage Temperature		T_{STG}	-55~+150	°C

Note Absolute maximum ratings are those values beyond which the device could be permanently damaged. Absolute maximum ratings are stress ratings only and functional device operation is not implied.

■ ELECTRICAL CHARACTERISTICS

For **UTC78L05** ($V_{IN}=10V$, $I_{OUT}=40mA$, $0^\circ C < T_J < 150^\circ C$, $C_1=0.33\mu F$, $C_o=0.1\mu F$, unless otherwise specified)

PARAMETER	SYMBOL	TEST CONDITIONS	MIN	TYP	MAX	UNIT
Output Voltage	V_{OUT}	$T_J=25^\circ C$	4.80	5.0	5.20	V
		$7V \leq V_{IN} \leq 20V, I_{OUT}=1mA-40mA$	4.75		5.25	V
		$7V \leq V_{IN} \leq V_{MAX}, I_{OUT}=1mA-70mA$	4.75		5.25	V (note 2)
Load Regulation	ΔV_{OUT}	$T_J=25^\circ C, I_{OUT}=1mA-100mA$		15	60	mV
		$T_J=25^\circ C, I_{OUT}=1mA-40mA$		8	30	mV
Line regulation	ΔV_{OUT}	$7V \leq V_{IN} \leq 20V, T_J=25^\circ C$		8	150	mV
		$8V \leq V_{IN} \leq 20V, T_J=25^\circ C$		6	100	mV
Quiescent Current	I_Q	$V_{IN}=10V, I_{OUT}=0mA, T_J=25^\circ C$		2.0	5.5	mA
Quiescent Current Change	ΔI_Q	$8V \leq V_{IN} \leq 20V$			1.5	mA
		$1mA \leq V_{IN} \leq 40mA$			0.1	mA
Output Noise Voltage	eN	$10Hz \leq f \leq 100kHz$		40		μV
Temperature coefficient of V_{OUT}	$\Delta V_O/\Delta T$	$I_{OUT}=5mA$		-0.65		$mV/^\circ C$
Ripple Rejection	RR	$8V \leq V_{IN} \leq 20V, f=120Hz, T_J=25^\circ C$	41	80		dB
Dropout Voltage	V_D	$T_J=25^\circ C$		1.7		V

For **UTC78L06** ($V_{IN}=12V$, $I_{OUT}=40mA$, $0^\circ C < T_J < 150^\circ C$, $C_1=0.33\mu F$, $C_o=0.1\mu F$, unless otherwise specified)

PARAMETER	SYMBOL	TEST CONDITIONS	MIN	TYP	MAX	UNIT
Output Voltage	V_{OUT}	$T_J=25^\circ C$	5.76	6.0	6.24	V
		$8.5V \leq V_{IN} \leq 20V, I_{OUT}=1mA-40mA$	5.70		6.30	V
		$8.5V \leq V_{IN} \leq V_{MAX}, I_{OUT}=1mA-70mA$	5.70		6.30	V (note 2)
Load Regulation	ΔV_{OUT}	$T_J=25^\circ C, I_{OUT}=1mA-100mA$		16	80	mV
		$T_J=25^\circ C, I_{OUT}=1mA-40mA$		9	40	mV
Line regulation	ΔV_{OUT}	$8.5V \leq V_{IN} \leq 20V, T_J=25^\circ C$		64	175	mV
		$9V \leq V_{IN} \leq 20V, T_J=25^\circ C$		54	125	mV
Quiescent Current	I_Q	$V_{IN}=12V, I_{OUT}=0mA, T_J=25^\circ C$		3.9	6.0	mA
Quiescent Current Change	ΔI_Q	$9V \leq V_{IN} \leq 20V$			1.5	mA
		$1mA \leq V_{IN} \leq 40mA$			0.1	mA
Output Noise Voltage	eN	$10Hz \leq f \leq 100kHz$		49		μV
Temperature coefficient of V_{OUT}	$\Delta V_O/\Delta T$	$I_{OUT}=5mA$		-0.75		$mV/^\circ C$
Ripple Rejection	RR	$10V \leq V_{IN} \leq 20V, f=120Hz, T_J=25^\circ C$	40	46		dB
Dropout Voltage	V_D	$T_J=25^\circ C$		1.7		V

■ ELECTRICAL CHARACTERISTICS (Cont.)

For UTC78L08 ($V_{IN}=14V$, $I_{OUT}=40mA$, $0^{\circ}C < T_J < 150^{\circ}C$, $C_1=0.33\mu F$, $C_o=0.1\mu F$, unless otherwise specified)

PARAMETER	SYMBOL	TEST CONDITIONS	MIN	TYP	MAX	UNIT
Output Voltage	V_{OUT}	$T_J=25^{\circ}C$	7.68	8.0	8.32	V
		$10.5V \leq V_{IN} \leq 23V, I_{OUT}=1mA-40mA$	7.60		8.40	V
		$10.5V \leq V_{IN} \leq V_{MAX}, I_{OUT}=1mA-70mA$	7.60		8.40	V(note 2)
Load Regulation	ΔV_{OUT}	$T_J=25^{\circ}C, I_{OUT}=1mA-100mA$		18	80	mV
		$T_J=25^{\circ}C, I_{OUT}=1mA-40mA$		10	40	mV
Line regulation	ΔV_{OUT}	$10.5V \leq V_{IN} \leq 23V, T_J=25^{\circ}C$		10	175	mV
		$11V \leq V_{IN} \leq 23V, T_J=25^{\circ}C$		8	125	mV
Quiescent Current	I_Q	$V_{IN}=14V, I_{OUT}=0mA, T_J=25^{\circ}C$		2.0	5.5	mA
Quiescent Current Change	ΔI_Q	$11V \leq V_{IN} \leq 23V$			1.5	mA
		$1mA \leq V_{IN} \leq 40mA$			0.1	mA
Output Noise Voltage	eN	$10Hz \leq f \leq 100kHz$		49		μV
Temperature coefficient of V_o	$\Delta V_o/\Delta T$	$I_{OUT}=5mA$		-0.75		$mV/^{\circ}C$
Ripple Rejection	RR	$11V \leq V_{IN} \leq 23V, f=120Hz, T_J=25^{\circ}C$	39	70		dB
Dropout Voltage	V_D	$T_J=25^{\circ}C$		1.7		V

For UTC78L09 ($V_{IN}=15V$, $I_{OUT}=40mA$, $0^{\circ}C < T_J < 150^{\circ}C$, $C_1=0.33\mu F$, $C_o=0.1\mu F$, unless otherwise specified)

PARAMETER	SYMBOL	TEST CONDITIONS	MIN	TYP	MAX	UNIT
Output Voltage	V_{OUT}	$T_J=25^{\circ}C$	8.64	9.0	9.36	V
		$11.5V \leq V_{IN} \leq 24V, I_{OUT}=1mA-40mA$	8.55		9.45	V
		$11.5V \leq V_{IN} \leq V_{MAX}, I_{OUT}=1mA-70mA$	8.55		9.45	V(note 2)
Load Regulation	ΔV_{OUT}	$T_J=25^{\circ}C, I_{OUT}=1mA-100mA$		19	90	mV
		$T_J=25^{\circ}C, I_{OUT}=1mA-40mA$		11	40	mV
Line regulation	ΔV_{OUT}	$11.5V \leq V_{IN} \leq 24V, T_J=25^{\circ}C$		90	200	mV
		$13V \leq V_{IN} \leq 24V, T_J=25^{\circ}C$		100	150	mV
Quiescent Current	I_Q	$V_{IN}=15V, I_{OUT}=0mA, T_J=25^{\circ}C$		2.0	6.0	mA
Quiescent Current Change	ΔI_Q	$13V \leq V_{IN} \leq 24V$			1.5	mA
		$1mA \leq V_{IN} \leq 40mA$			0.1	mA
Output Noise Voltage	eN	$10Hz \leq f \leq 100kHz$		70		μV
Temperature coefficient of V_{OUT}	$\Delta V_o/\Delta T$	$I_{OUT}=5mA$		-0.75		$mV/^{\circ}C$
Ripple Rejection	RR	$12V \leq V_{IN} \leq 24V, f=120Hz, T_J=25^{\circ}C$	38	44		dB
Dropout Voltage	V_D	$T_J=25^{\circ}C$		1.7		V

For UTC78L10 ($V_{IN}=16V$, $I_{OUT}=40mA$, $0^{\circ}C < T_J < 150^{\circ}C$, $C_1=0.33\mu F$, $C_o=0.1\mu F$, unless otherwise specified)

PARAMETER	SYMBOL	TEST CONDITIONS	MIN	TYP	MAX	UNIT
Output Voltage	V_{OUT}	$T_J=25^{\circ}C$	9.6	10.0	10.4	V
		$12.5V \leq V_{IN} \leq 25V, I_{OUT}=1mA-40mA$	9.5		10.5	V
		$12.5V \leq V_{IN} \leq V_{MAX}, I_{OUT}=1mA-70mA$	9.5		10.5	V(note 2)
Load Regulation	ΔV_{OUT}	$T_J=25^{\circ}C, I_{OUT}=1mA-100mA$		20	90	mV
		$T_J=25^{\circ}C, I_{OUT}=1mA-40mA$		11	40	mV
Line regulation	ΔV_{OUT}	$12.5V \leq V_{IN} \leq 25V, T_J=25^{\circ}C$		100	200	mV
		$14V \leq V_{IN} \leq 25V, T_J=25^{\circ}C$		100	170	mV
Quiescent Current	I_Q	$V_{IN}=17V, I_{OUT}=0mA, T_J=25^{\circ}C$		2.0	6.0	mA
Quiescent Current Change	ΔI_Q	$12.5V \leq V_{IN} \leq 25V$			1.5	mA
		$1mA \leq V_{IN} \leq 40mA$			0.1	mA
Output Noise Voltage	eN	$10Hz \leq f \leq 100kHz$		74		μV
Temperature coefficient of V_{OUT}	$\Delta V_o/\Delta T$	$I_{OUT}=5mA$		-0.8		$mV/^{\circ}C$
Ripple Rejection	RR	$15V \leq V_{IN} \leq 25V, f=120Hz, T_J=25^{\circ}C$	38	43		dB
Dropout Voltage	V_D	$T_J=25^{\circ}C$		1.7		V

■ ELECTRICAL CHARACTERISTICS (Cont.)

For UTC78L12 ($V_{IN}=19V$, $I_{OUT}=40mA$, $0^{\circ}C < T_J < 150^{\circ}C$, $C_1=0.33\mu F$, $C_o=0.1\mu F$, unless otherwise specified)

PARAMETER	SYMBOL	TEST CONDITIONS	MIN	TYP	MAX	UNIT
Output Voltage	V_{OUT}	$T_J=25^{\circ}C$	11.52	12.0	12.48	V
		$14.5V \leq V_{IN} \leq 27V, I_{OUT}=1mA-40mA$	11.40		12.60	V
		$14.5V \leq V_{IN} \leq V_{MAX}, I_{OUT}=1mA-70mA$	11.40		12.60	V(note 2)
Load Regulation	ΔV_{OUT}	$T_J=25^{\circ}C, I_{OUT}=1mA-100mA$		22	100	mV
		$T_J=25^{\circ}C, I_{OUT}=1mA-40mA$		13	50	mV
Line regulation	ΔV_{OUT}	$14.5V \leq V_{IN} \leq 27V, T_J=25^{\circ}C$		25	300	mV
		$16V \leq V_{IN} \leq 27V, T_J=25^{\circ}C$		20	250	mV
Quiescent Current	I_Q	$V_{IN}=19V, I_{OUT}=0mA, T_J=25^{\circ}C$		2.0	6.0	mA
Quiescent Current Change	ΔI_Q	$16V \leq V_{IN} \leq 27V$			1.5	mA
		$1mA \leq V_{IN} \leq 40mA$			0.1	mA
Output Noise Voltage	eN	$10Hz \leq f \leq 100kHz$		80		μV
Temperature coefficient of V_{OUT}	$\Delta V_O/\Delta T$	$I_{OUT}=5mA$		-1.0		$mV/^{\circ}C$
Ripple Rejection	RR	$15V \leq V_{IN} \leq 25V, f=120Hz, T_J=25^{\circ}C$	37	65		dB
Dropout Voltage	V_D	$T_J=25^{\circ}C$		1.7		V

For UTC78L15 ($V_{IN}=23V$, $I_{OUT}=40mA$, $0^{\circ}C < T_J < 150^{\circ}C$, $C_1=0.33\mu F$, $C_o=0.1\mu F$, unless otherwise specified)

PARAMETER	SYMBOL	TEST CONDITIONS	MIN	TYP	MAX	UNIT
Output Voltage	V_{OUT}	$T_J=25^{\circ}C$	14.40	15.0	15.60	V
		$17.5V \leq V_{IN} \leq 30V, I_{OUT}=1mA-40mA$	14.25		15.75	V
		$17.5V \leq V_{IN} \leq V_{MAX}, I_{OUT}=1mA-70mA$	14.25		15.75	V(note 2)
Load Regulation	ΔV_{OUT}	$T_J=25^{\circ}C, I_{OUT}=1mA-100mA$		25	150	mV
		$T_J=25^{\circ}C, I_{OUT}=1mA-40mA$		15	75	mV
Line Regulation	ΔV_{OUT}	$17.5V \leq V_{IN} \leq 30V, T_J=25^{\circ}C$		25	150	mV
		$20V \leq V_{IN} \leq 30V, T_J=25^{\circ}C$		15	75	mV
Quiescent Current	I_Q	$V_{IN}=23V, I_{OUT}=0mA, T_J=25^{\circ}C$		2.2	6.5	mA
Quiescent Current Change	ΔI_Q	$20V \leq V_{IN} \leq 30V$			1.5	mA
		$1mA \leq V_{IN} \leq 40mA$			0.1	mA
Output Noise Voltage	eN	$10Hz \leq f \leq 100kHz$		90		μV
Temperature Coefficient of V_{OUT}	$\Delta V_O/\Delta T$	$I_{OUT}=5mA$		-1.3		$mV/^{\circ}C$
Ripple Rejection	RR	$18.5V \leq V_{IN} \leq 28.5V, f=120Hz, T_J=25^{\circ}C$	34	63		dB
Dropout Voltage	V_D	$T_J=25^{\circ}C$		1.7		V

For UTC78L18 ($V_{IN}=27V$, $I_{OUT}=40mA$, $0^{\circ}C < T_J < 150^{\circ}C$, $C_1=0.33\mu F$, $C_o=0.1\mu F$, unless otherwise specified)

PARAMETER	SYMBOL	TEST CONDITIONS	MIN	TYP	MAX	UNIT
Output Voltage	V_{OUT}	$T_J=25^{\circ}C$	17.64	18.0	18.36	V
		$21V \leq V_{IN} \leq 33V, I_{OUT}=1mA-40mA$	17.46		18.54	V
		$21V \leq V_{IN} \leq V_{MAX}, I_{OUT}=1mA-70mA$	17.46		18.54	V(note 2)
Load Regulation	ΔV_{OUT}	$T_J=25^{\circ}C, I_{OUT}=1mA-100mA$		27	180	mV
		$T_J=25^{\circ}C, I_{OUT}=1mA-40mA$		19	90	mV
Line Regulation	ΔV_{OUT}	$21V \leq V_{IN} \leq 33V, T_J=25^{\circ}C$		145	300	mV
		$22V \leq V_{IN} \leq 33V, T_J=25^{\circ}C$		135	250	mV
Quiescent Current	I_Q	$V_{IN}=27V, I_{OUT}=0mA, T_J=25^{\circ}C$		2.0	6.0	mA
Quiescent Current Change	ΔI_Q	$21V \leq V_{IN} \leq 33V$			1.5	mA
		$1mA \leq V_{IN} \leq 40mA$			0.1	mA
Output Noise Voltage	eN	$10Hz \leq f \leq 100kHz$		150		μV
Temperature Coefficient of V_{OUT}	$\Delta V_O/\Delta T$	$I_{OUT}=5mA$		-1.8		$mV/^{\circ}C$
Ripple Rejection	RR	$23V \leq V_{IN} \leq 33V, f=120Hz, T_J=25^{\circ}C$	34	48		dB
Dropout Voltage	V_D	$T_J=25^{\circ}C$		1.7		V

■ ELECTRICAL CHARACTERISTICS (Cont.)

For UTC78L24 ($V_{IN}=33V$, $I_{OUT}=40mA$, $0^{\circ}C < T_J < 150^{\circ}C$, $C_1=0.33\mu F$, $C_o=0.1\mu F$, unless otherwise specified)

PARAMETER	SYMBOL	TEST CONDITIONS	MIN	TYP	MAX	UNIT
Output Voltage	V_{OUT}	$T_J=25^{\circ}C$	23.04	24.0	24.96	V
		$27V \leq V_{IN} \leq 38V, I_{OUT}=1mA-40mA$	22.8		25.2	V
		$27V \leq V_{IN} \leq V_{MAX}, I_{OUT}=1mA-70mA$	22.8		25.2	V(note 2)
Load Regulation	ΔV_{OUT}	$T_J=25^{\circ}C, I_{OUT}=1mA-100mA$		41	240	mV
		$T_J=25^{\circ}C, I_{OUT}=1mA-40mA$		28	120	mV
Line Regulation	ΔV_{OUT}	$27V \leq V_{IN} \leq 38V, T_J=25^{\circ}C$		160	300	mV
		$28V \leq V_{IN} \leq 38V, T_J=25^{\circ}C$		150	250	mV
Quiescent Current	I_Q	$V_{IN}=33V, I_{OUT}=0mA, T_J=25^{\circ}C$		2.2	6.0	mA
Quiescent Current Change	ΔI_Q	$27V \leq V_{IN} \leq 38V$			1.5	mA
		$1mA \leq V_{IN} \leq 40mA$			0.1	mA
Output Noise Voltage	eN	$10Hz \leq f \leq 100kHz$		200		μV
Temperature Coefficient of V_{OUT}	$\Delta V_O/\Delta T$	$I_{OUT}=5mA$		-2.0		mV/ $^{\circ}C$
Ripple Rejection	RR	$27V \leq V_{IN} \leq 38V, f=120Hz, T_J=25^{\circ}C$	34	45		dB
Dropout Voltage	V_D	$T_J=25^{\circ}C$		1.7		V

Note 1. The Maximum steady state usable output current is dependent on input voltage, heat sinking, lead length of the package and copper pattern of PCB.

2. Power dissipation < 0.5W

■ APPLICATION CIRCUIT

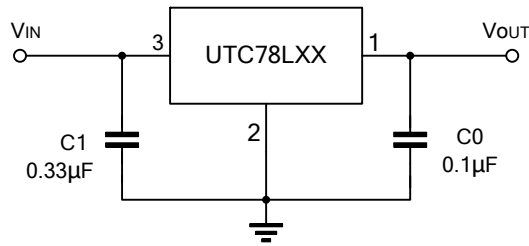

- Notes:
1. To specify an output voltage, substitute voltage value for "XX".
 2. Bypass capacitors are recommended for optimum stability and transient response and should be located as close as possible to the regulators.

■ TEST CIRCUIT

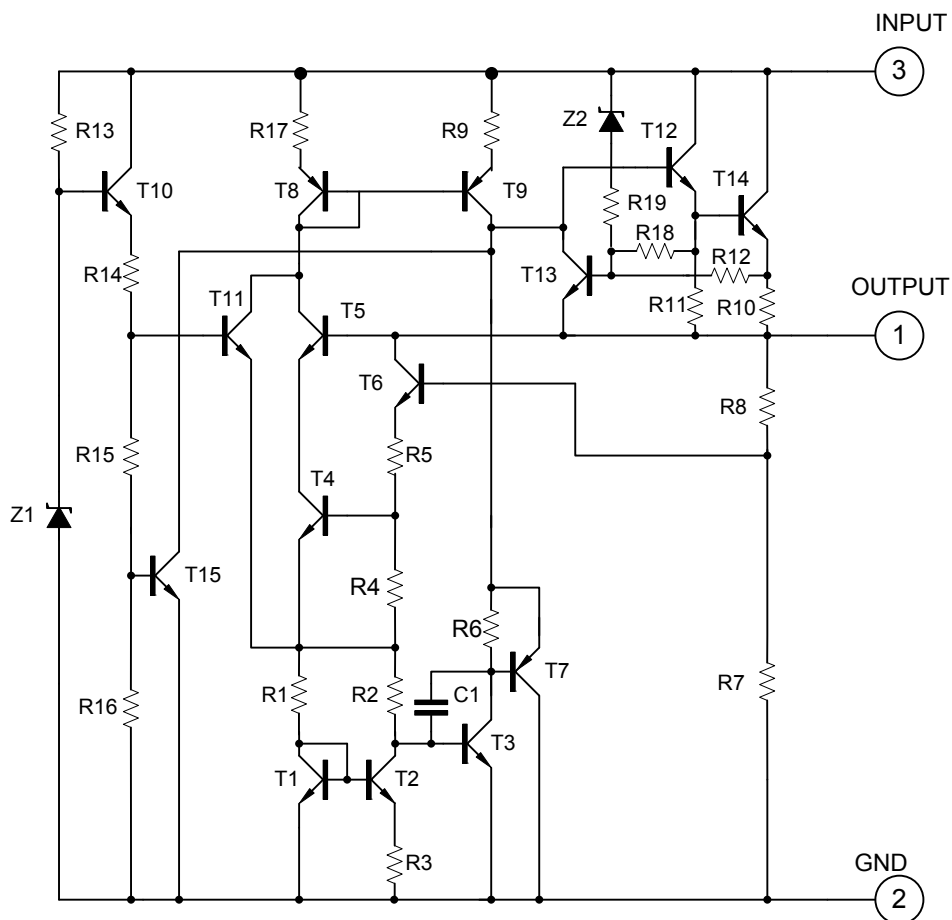

■ TYPICAL CHARACTERISTICS

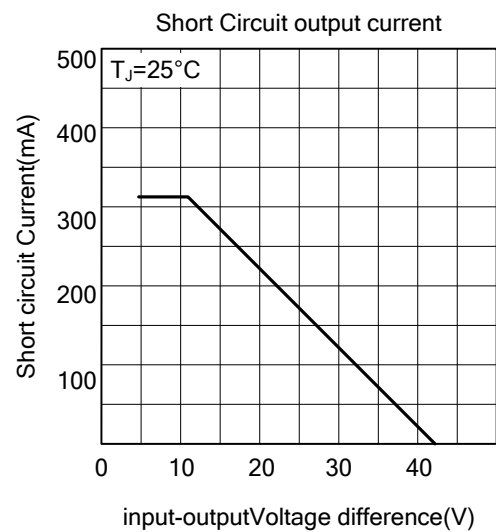
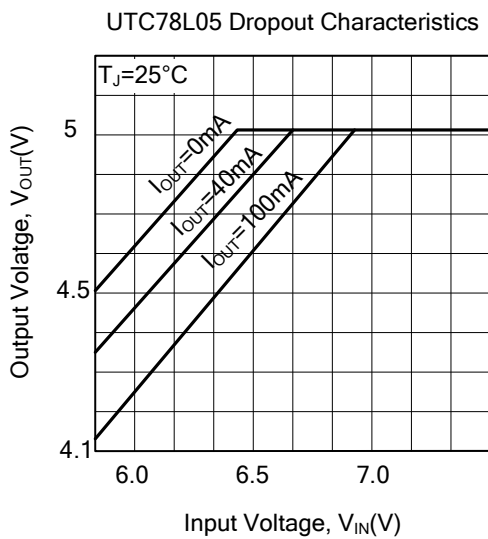
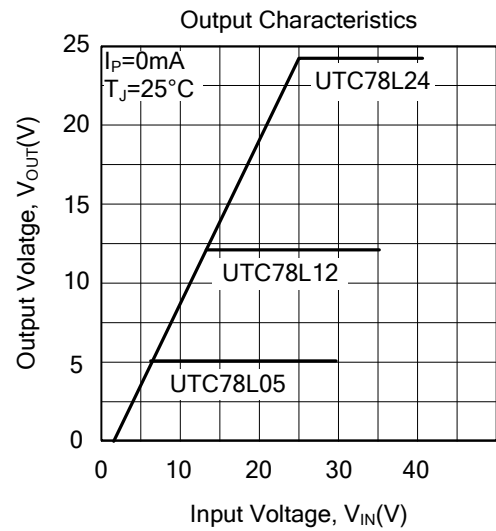
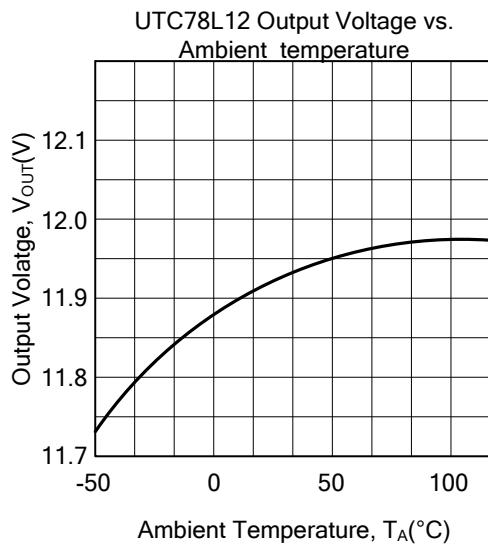
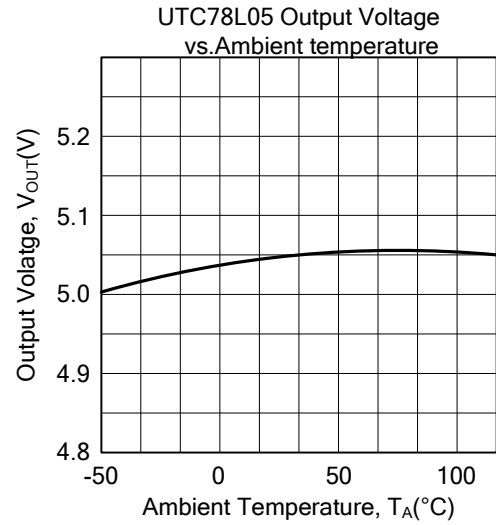
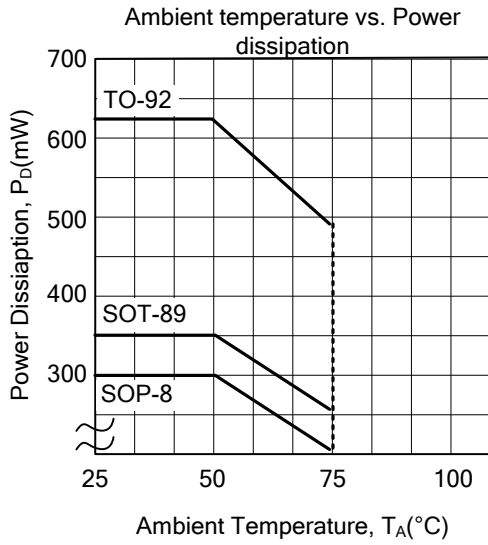

■ TYPICAL CHARACTERISTICS(Cont.)

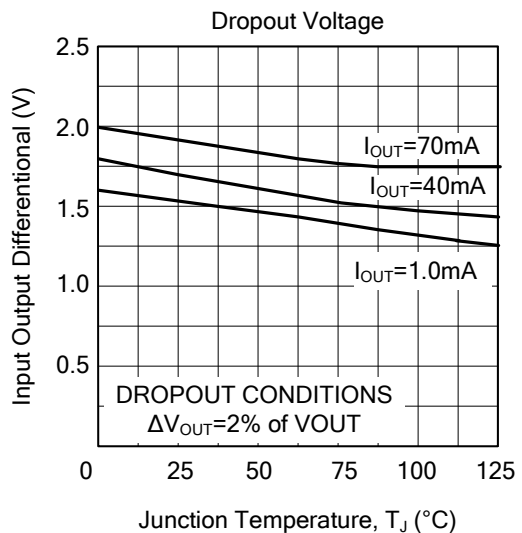
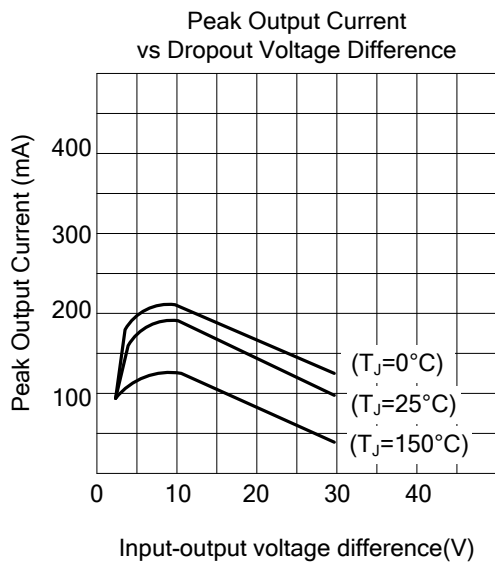
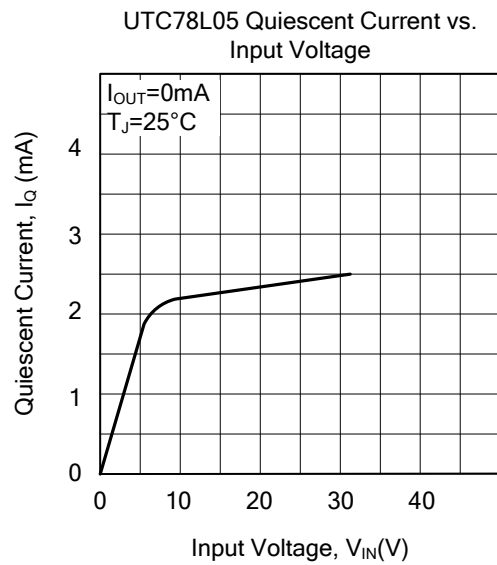
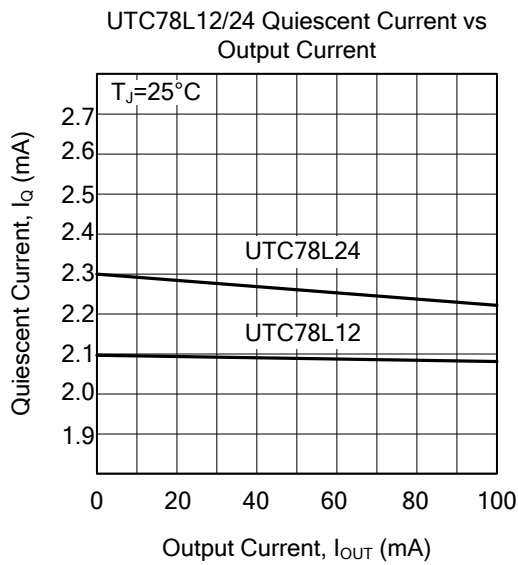

UTC assumes no responsibility for equipment failures that result from using products at values that exceed, even momentarily, rated values (such as maximum ratings, operating condition ranges, or other parameters) listed in products specifications of any and all UTC products described or contained herein. UTC products are not designed for use in life support appliances, devices or systems where malfunction of these products can be reasonably expected to result in personal injury. Reproduction in whole or in part is prohibited without the prior written consent of the copyright owner. The information presented in this document does not form part of any quotation or contract, is believed to be accurate and reliable and may be changed without notice.