

4

3

2

1

THE INFORMATION ON THIS DRAWING IS THE PROPERTY OF CELESTRA CORPORATION.
 IS DISCLOSED IN CONFIDENCE AND IS NOT TO BE REPRODUCED,USED OR DISCLOSED
 EXCEPT FOR THE PURPOSE FOR WHICH FURNISHED

CELESTRA CAT NO.	WIRE SIZE		BOLT SIZE	A	B	C	D	F	H	ID
	CODE	FLEX		±0.06	MIN	±0.04	±0.01	±0.02	±0.04	±0.01
DA0138	1 AWG	150/24	3/8	1.83	0.98	0.68	0.11	0.38	0.60	0.36

NOTE

1. ALL DIMENSIONS ARE IN INCH OTHERWISE SPECIFIED.

2. All DA,DB,LA,LB,WP AND J SERIES CAT.NO.S ARE LISTED BY" UNDERWRITEERS INC" AND "CSA" FOR USE ON CODE WIRES AND FLEX STRANDED CABLES.

FOR PRE-FIX CAT.NO.WITH "L"HAS NOT PEEP HOLE UNLESS OTHERWISE SPECIFIED IN THE SUFFIX OF THE CAT.NO.WITH P.

MATERIAL BODY: HIGH CONDUCTIVITY WROUGHT COPPER

FINISH ELECTOR-TIN PLATE UNLESS OTHERWISE SPECIFIED PLATE PER MIL-T-16366 SUFFIX CAT. NO. WITH "SP" FOR SILVER.

INSTALLATION GUIDE
 DIE CODE=37
 DIE COLOR=GREEN



Cust.P/N /

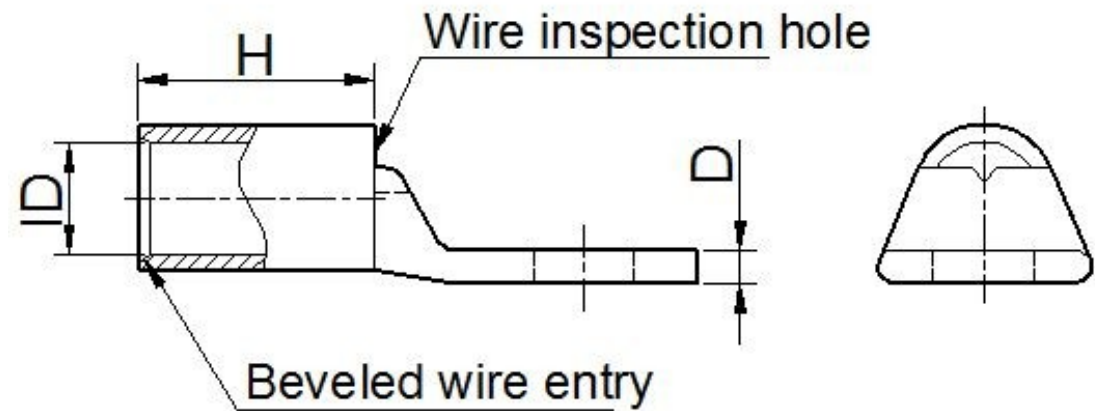
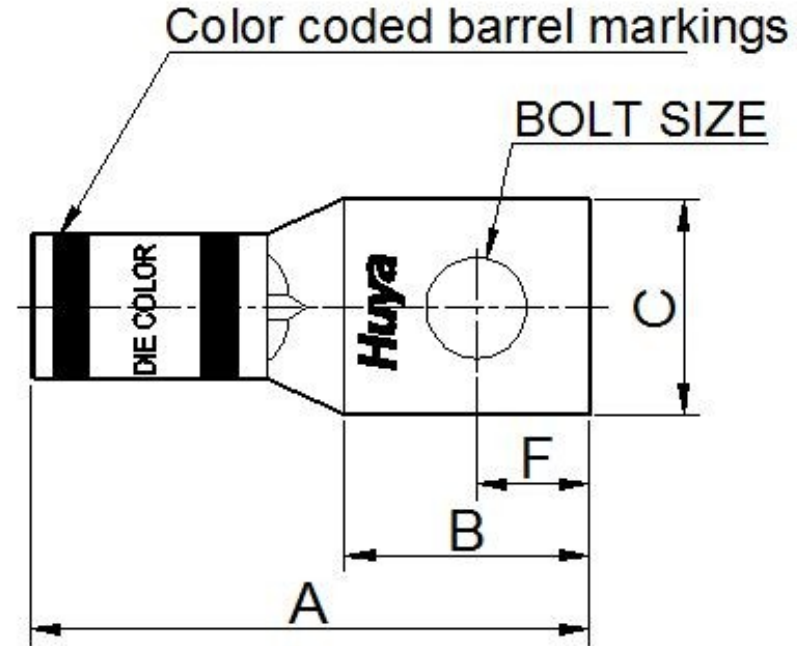

A

A

REV	DATE	DWN	CHK	DESCRIPTION	ECN
01	05/Jul/12	IRIS JIAN	SINIA QIU	Update Drawing Frame.	N/A
00	01/Dec/08	Tang ZS	SC Chen	Celestra Standards Spec. Initialed.	N/A

Huya[®]

CELESTRA CORPORATION

76. ZHONGSI HUANCUN ROAD, ZHONGCUN TOWN.

www.celestra.cn

TITLE WIRE CONNECTORS AND SOLDERING LUGS FOR CODE AND FLEX CABLE					
MATERIAL: HIGH CONDUCTIVITY		PRT NO. DA0138		SCALE NTS	
FINISH: ELECTRO-TIN PLATE		DWG NO. 186-01081211		UNIT INCH	
				THIRD ANGL	

4

3

2

1