



SHENZHEN HAOLIN ELECTRONICS TECHNOLOGY CO., LTD

DO-201AD SCHOTTKY BARRIER DIODE

SR520-SR5200

FEATURES

- Plastic package has Underwriters Laboratory Flammability Classification 94V-0
- Metal silicon junction ,majority carrier conduction
- Guard ring for overvoltage protection
- Low power loss ,high efficiency
- High current capability ,low forward voltage drop
- High surge capability
- For use in low voltage ,high frequency inverters, free wheeling ,and polarity protection applications
- High temperature soldering guaranteed:260°C/10 seconds at terminals
- Component in accordance to RoHS 2002/95/EC and WEEE 2002/96/EC

Reverse Voltage - 20 to 200 Volts
Forward Current - 5.0Ampere

DO-201AD (DO-27)

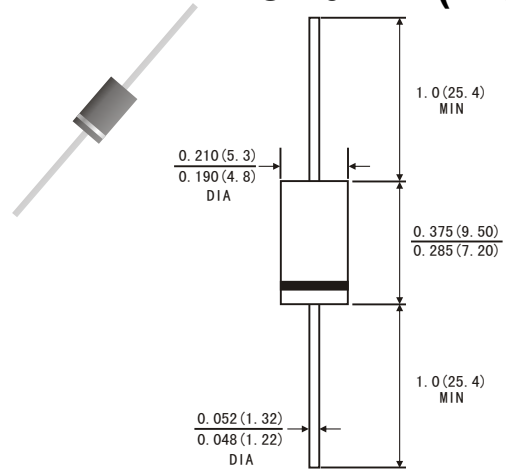

Dimensions in inches and (millimeters)

MECHANICAL DATA

- *Case:* JEDEC DO-201AD molded plastic body
- *Terminals:* Plated axial leads, solderable per MIL-STD-750,method 2026
- *Polarity:* color band denotes cathode end
- *Mounting Position:* Any
- *Weight:* 0.041ounce, 1.15 grams

MAXIMUM RATINGS AND ELECTRICAL CHARACTERISTICS

(Ratings at 25°C ambient temperature unless otherwise specified ,Single phase ,half wave ,resistive or inductive load. For capacitive load,derate by 20%.)

	Symbols	SR 520	SR 530	SR 540	SR 550	SR 560	SR 580	SR 5100	SR 5150	SR 5200	Units	
Maximum repetitive peak reverse voltage	V _{RRM}	20	30	40	50	60	80	100	150	200	Volts	
Maximum RMS voltage	V _{RMS}	14	21	28	35	42	57	71	105	140	Volts	
Maximum DC blocking voltage	V _{DC}	20	30	40	50	60	80	100	150	200	Volts	
Maximum average forward rectified current 0.375"(9.5mm) lead length(see fig.1)	I(AV)	5.0									Amps	
Peak forward surge current 8.3ms single half sine-wave superimposed on rated load (JEDEC method at rated T _j)	I _{FSM}	150.0									Amps	
Maximum instantaneous forward voltage at 5.0 A(Note 1)	V _F	0.55			0.70		0.85		0.90	0.95	Volts	
Maximum instantaneous reverse current at rated DC blocking voltage(Note 1)	I _R	0.5									mA	
		50			25							
Typical junction capacitance(Note 3)	C _J	500			400						pF	
Typical thermal resistance (Note 2)	R _{θJA}					25.0						°C/W
	R _{θJL}					8.0						
Operating junction temperature range	T _J	-65 to +125				-65 to +150					°C	
Storage temperature range	T _{STG}	-65 to +150									°C	

Notes: 1.Pulse test: 300μs pulse width,1% duty cycle

2.Thermal resistance from junction to lead vertical P.C.B. mounted , 0.375"(9.5mm)lead length

3.Measured at 1MHz and reverse voltage of 4.0 volts

RATINGS AND CHARACTERISTIC CURVES SR520 THRU SR5200

FIG.1-FORWARD CURRENT DERATING CURVE

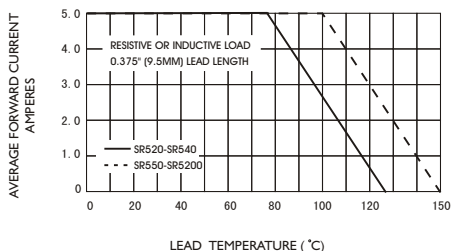

FIG.2-MAXIMUM NON-REPETITIVE PEAK FORWARD SURGE CURRENT

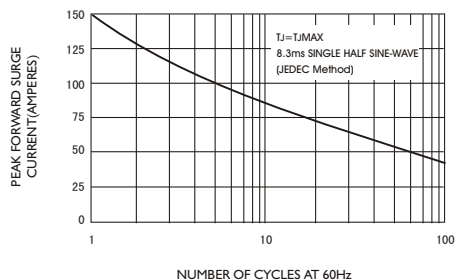

FIG.3-TYPICAL INSTANTANEOUS FORWARD CHARACTERISTICS

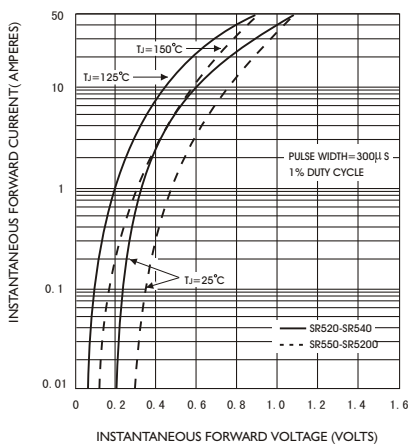

FIG.4-TYPICAL REVERSE CHARACTERISTICS

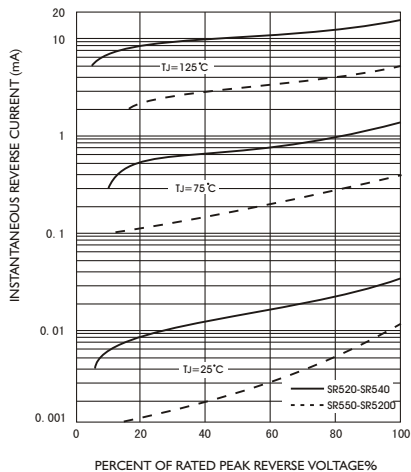

FIG.5-TYPICAL JUNCTION CAPACITANCE

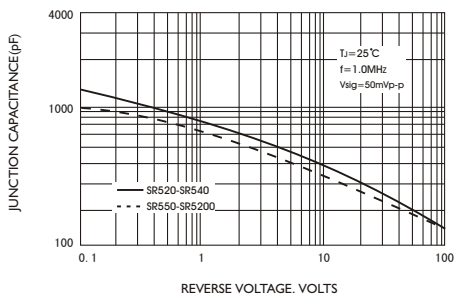

FIG.6-TYPICAL TRANSIENT THERMAL IMPEDANCE

