

贴片电阻选择指南

■ 通用贴片电阻

SERIES	SIZE/ mm	POWER RATING	MAX WORKING VOLTAGE	TOLERANCE	RESISTANCE RANGE
CR0402	0402 1.00*0.50	1/16W	50V	1%	1Ω-10MΩ
				5%	1Ω-10MΩ
CR0603	0603 1.60*0.80	1/10W	50V	0.5%	10Ω-1MΩ
				1%	1Ω-10MΩ
				5%	1Ω-22MΩ
CR0805	0805 2.00*1.25	1/8W	150V	0.5%	10Ω-1MΩ
				1%	1Ω-10MΩ
				5%	1Ω-22MΩ
CR1206	1206 3.10*1.60	1/4W	200V	0.5%	10Ω-1MΩ
				1%	1Ω-10MΩ
				5%	1Ω-22MΩ
CR1210	1210 3.10*2.50	1/2W	200V	1%	1Ω-10MΩ
				5%	1Ω-22MΩ
CR2010	2010 5.00*2.50	3/4W	200V	1%	1Ω-10MΩ
				5%	1Ω-22MΩ
CR2512	2512 6.25*3.10	1/W	200V	1%	1Ω-10MΩ
				5%	1Ω-22MΩ

■ 零欧姆电阻跳线

SERIES	SIZE	RATED CURRENT	TOLERANCE	RESISTANCE RANGE
CR0402	0402	1A	<0.05Ω	0Ω
CR0603	0603	1A		
CR0805	0805	1.5A		
CR1206	1206	1.9A		
CR1210	1210	2.2A		
CR2010	2010	3A		
CR2512	2512	3A		

■ 贴片电阻阵列

SERIES	SIZE/mm	POWER RATING	MAX WORKING VOLTAGE	TOLERANCE	RESISTANCE RANGE
CA022A	0404 1.00*1.00	1/16W	50V	1%	10Ω-1MΩ
				5%	1Ω-1MΩ
CA024A	0804 2.00*1.00	1/16W	50V	1%	10Ω-1MΩ
				5%	1Ω-1MΩ
CA034A	1206 3.20*1.50	1/10W	50V	1%	10Ω-1MΩ
				5%	1Ω-1MΩ

通用贴片电阻

■ 特点

1. 表面贴装器件 (SMD)，适用于自动贴装表面安装应用程序
2. 雾锡电镀终端层的回流和波峰焊
3. 氧化铝陶瓷基片体，高的热和机械抗蚀

■ 应用

1. 有关电子电路板通用。
2. 计算机行业：主板，笔记本电脑，液晶显示器，显示卡，硬盘
3. 通信行业：手机，电话机
5. 消费类多媒体领域：液晶显示器，DVD播放器，MP3/4播放器，数码相机
6. 供电部门：DC电源，适配器，充电器
7. 一般住宅和工业电子设备：空调，冰箱



■ 电气特性

SERIES	CR0402	CR0603	CR0805	CR1206	CR1210	CR2010	CR2512
Size Code in Inch(mm)	0402(1005)	0603(1608)	0805(2012)	1206(3216)	1210(3225)	2010(5025)	2512(6432)
Operating Temperature	-55°C~+125°C	-55°C~+125°C	-55°C~+125°C	-55°C~+125°C	-55°C~+125°C	-55°C~+125°C	-55°C~+125°C
Power Rating @T _{amb} =70°C	1/16W	1/10W	1/8W	1/4W	1/2W	3/4W	1W
Maximum Working Voltage	50V	50V	150V	200V	200V	200V	200V
Maximum Overload Voltage	100V	100V	300V	400V	400V	400V	400V
Dielectric Withstand Voltage	50V	100V	300V	500V	500V	500V	500V
Resistance Range	0.5%		10Ω-1MΩ	10Ω-1MΩ	10Ω-1MΩ		
	1%(E96)	1Ω-10MΩ	1Ω-10MΩ	1Ω-10MΩ	1Ω-10MΩ	1Ω-10MΩ	1Ω-10MΩ
	5%(E24)	1Ω-10MΩ	1Ω-22MΩ	1Ω-22MΩ	1Ω-22MΩ	1Ω-22MΩ	1Ω-22MΩ
	<0.05Ω	0Ω	0Ω	0Ω	0Ω	0Ω	0Ω
Temperature Coefficient	1Ω-10Ω	-250 ~+500 ppm/°C	-250 ~+500 ppm/°C	-250 ~+500 ppm/°C	-250 ~+500 ppm/°C	-250 ~+500 ppm/°C	-250 ~+500 ppm/°C
	>10Ω-22MΩ	±200ppm/°C	±200ppm/°C	±200ppm/°C	±200ppm/°C	±200ppm/°C	±200ppm/°C
	>10Ω-1MΩ for 0.5%	±100ppm/°C	±100ppm/°C	±100ppm/°C	±100ppm/°C	±100ppm/°C	±100ppm/°C
	>10Ω-10MΩ for 1%	±100ppm/°C	±100ppm/°C	±100ppm/°C	±100ppm/°C	±100ppm/°C	±100ppm/°C
Rated Continue Working Voltage= $\sqrt{\text{rated power(W)} \times \text{Resistance value}(\Omega)}$ or Maximum Working Voltage listed above, whichever is lower							
Zero Ohm Jumper Rated Current	1A	1A	1.5A	1.9A	2.2A	3A	3A

■ 尺寸 (单位mm)

SERIES	CR0402	CR0603	CR0805	CR1206	CR1210	CR2010	CR2512
L	1.00±0.05	1.60±0.15	2.00±0.15	3.10±0.15	3.10±0.15	5.00±0.20	6.25±0.20
W	0.50±0.05	0.80±0.10	1.25±0.15	1.60±0.15	2.50±0.15	2.50±0.20	3.10±0.20
T	0.35±0.05	0.45±0.10	0.50±0.10	0.55±0.10	0.55±0.15	0.55±0.15	0.55±0.15
E	0.15±0.10	0.20±0.20	0.35±0.20	0.45±0.25	0.45±0.25	0.65±0.25	0.85±0.25
e	0.20±0.10	0.30±0.20	0.40±0.20	0.40±0.25	0.60±0.35	0.60±0.25	0.95±0.25

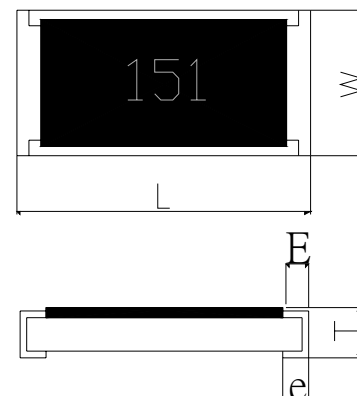

贴片电阻阵列

■ 特点

1. 芯片集成，表面贴装器件（SMD），适用于自动贴装表面安装应用程序
2. 雾锡电镀终端层的回流和波峰焊
3. 氧化铝陶瓷基片体，高的热和机械抗蚀

■ 应用

1. 对于SMT效率，电路板空间最小化和节省成本，适用于：电信，移动电话，笔记本电脑，所有功能于一身的主机板，硬盘等。
2. 与IC的细间距匹配终端间距，降低PC电路板空间，并提高接线布局

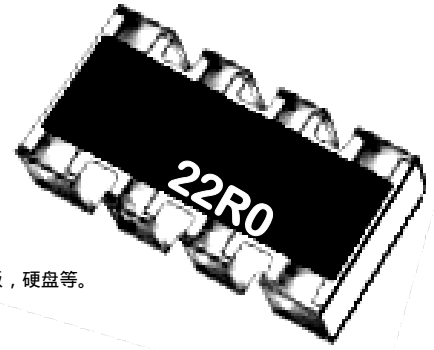

■ 电气特性

SERIES		CA022A	CA024A	CA034A
Size Code in Inch(mm)		0402x2(1005x2)	0402x4(1005x4)	0603x4(1608x4)
Operating Temperature		-55°C~+125°C	-55°C~+125°C	-55°C~+125°C
Power Rating @T _{amb} =70°C		1/16W	1/16W	1/10W
Maximum Working Voltage		50V	50V	50V
Maximum Overload Voltage		100V	100V	100V
Dielectric Withstand Voltage		50V	50V	100V
Resistance Range	1%(E96)	10Ω-1MΩ	10Ω-1MΩ	10Ω-1MΩ
	5%(E24)	1Ω-1MΩ	1Ω-1MΩ	1Ω-1MΩ
	<0.05Ω	0Ω	0Ω	0Ω
Temperature Coefficient	1Ω-10Ω	-250 ~ +500 ppm/°C	-250 ~ +500 ppm/°C	-250 ~ +500 ppm/°C
	>10Ω-1MΩ	±200ppm/°C	±200ppm/°C	±200ppm/°C
Rated Continue Working Voltage= $\sqrt{\text{rated power(W)} \times \text{Resistance value}(\Omega)}$ or Maximum Working Voltage listed above, whichever is lower				
Zero Ohm Jumper Rated Current		0.63A	0.63A	1A

■ 尺寸 (单位mm)

SERIES	CA022A	CA024A	CA034A
L	1.00±0.10	2.00±0.10	3.20±0.20
W	1.00±0.10	1.00±0.10	1.50±0.20
H	0.35±0.05	0.40±0.05	0.55±0.05
L1	0.19±0.10	0.18±0.10	0.30±0.15
L2	0.28±0.10	0.26±0.10	0.30±0.20
P	0.67±0.10	0.67±0.10	0.80±0.15
Q	0.33±0.10	0.33±0.10	0.50±0.15

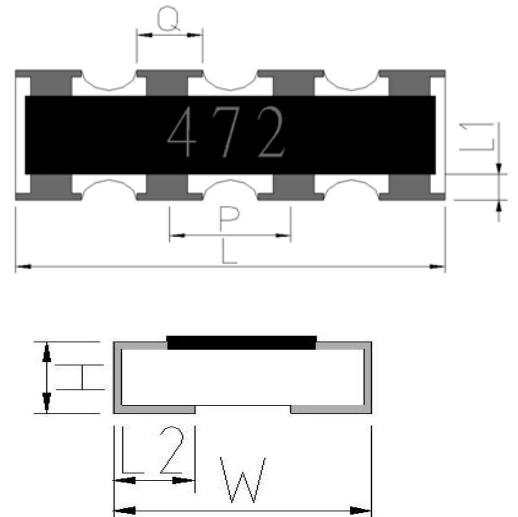

贴片电阻通用数据

■ 结构

芯片电阻器构成由氧化铝陶瓷基片体，形成于陶瓷表面电阻层。通过激光微调isadjusted电阻值。电阻层覆盖保护层。终止是由镍层为阻隔层和雾锡作为终止层电镀。

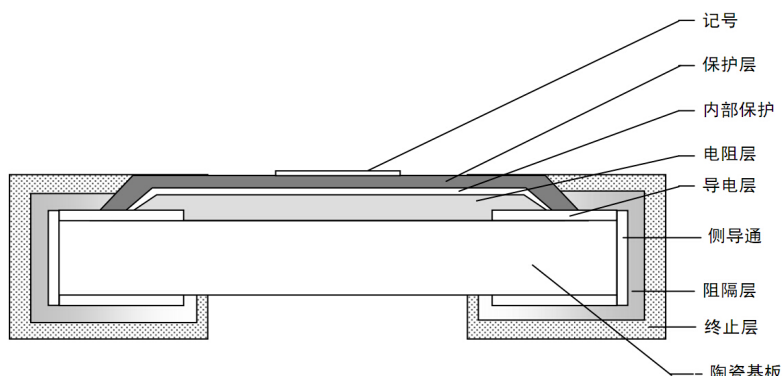

■ 记号



no marking for size 0402 product



For 5% (E24) product, 3 digits marking: 2D as resistance value & 1D as multiplier
Example 220: $22 \times 10^0 = 22 \Omega$



For size 0603 1%(E96) product, 3 digits marking by EIA-96 code: 2D code as resistance value & 1alphabet as multiplier.
Example 30X: $200 \times 10^{-1} = 20 \Omega$



For others 1%(E96) product except size 0603, 3 digits marking: 2D as resistance value & 1D as multiplier
Example 2201: $220 \times 10^1 = 2200 \Omega$

E-96 Marking Rule															
CODE VALUE	CODE VALUE	CODE VALUE	CODE VALUE	CODE VALUE	CODE VALUE	CODE VALUE	CODE VALUE	CODE VALUE	CODE VALUE	CODE VALUE					
01	100	13	133	25	178	37	237	49	316	61	422	73	562	85	750
02	102	14	137	26	182	38	243	50	324	62	432	74	576	86	768
03	105	15	140	27	187	39	249	51	332	63	442	75	590	87	787
04	107	16	143	28	191	40	255	52	340	64	453	76	604	88	806
05	110	17	147	29	196	41	261	53	348	65	464	77	619	89	825
06	113	18	150	30	200	42	267	54	357	66	475	78	634	90	845
07	115	19	154	31	205	43	274	55	365	67	487	79	649	91	866
08	118	20	158	32	210	44	280	56	374	68	499	80	665	92	887
09	121	21	162	33	215	45	287	57	383	69	511	81	681	93	909
10	124	22	165	34	221	46	294	58	392	70	523	82	698	94	931
11	127	23	169	35	226	47	301	59	402	71	536	83	715	95	953
12	130	24	174	36	223	48	309	60	412	72	549	84	732	96	976

First 2 digits represented the 3 digits value of E-96 series, the third alphabet as multiplier
 $Y=10^{-2}$, $X=10^{-1}$, $A=10^0$, $B=10^1$, $C=10^2$, $D=10^3$, $E=10^4$, $F=10^5$

贴片电阻通用数据

■ 额定功率

IEC60115-8定义的额定功率。最大耗散（P最高）的额定功率为环境温度（环境温度Tamb）的函数的百分比。对于电阻的环境温度下运行超过70℃，额定功率可降级为温度升高。

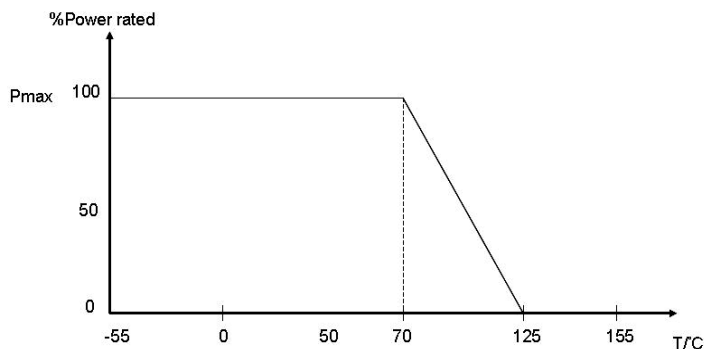

■ 温度系数

$$TC = \frac{R_2 - R_1}{R_1 (t_2 - t_1)} \times 10^6 (\text{PPM}/^\circ\text{C})$$

Example: TC=100 (100ppm/°C)

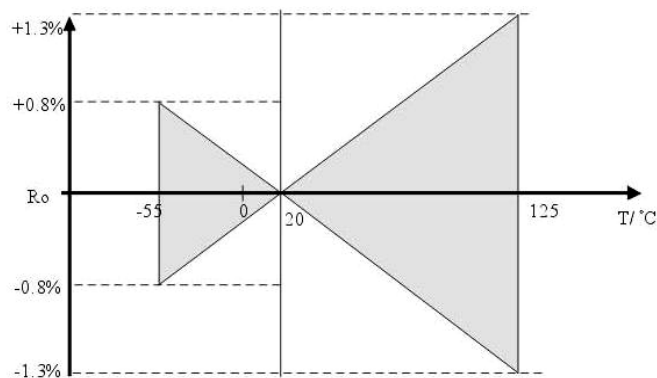

■ 测试与要求

Description	Test Methods	Procedure
Temperature Coefficient	JIS C5202 5.2	Keep the sample at upper temperature for 30 minutes and measure the resistance value. Resistance value change in temperature coefficient term within spec.
Short Time Overload	JIS C5202 5.5	Apply 2.5 times rated voltage on sample (if 2.5 times rated voltage exceeds the maximum overload voltage, the maximum overload voltage shall be applied as test voltage). Resistance value change within spec.
Dielectric withstand voltage	MIL-STD-202F-method 301	Applied test voltage from 0 V to maximum withstand voltage with DC voltage across electrode and the center of body for 60±5seconds. No failure on burning or breakdown.
Resistance to Soldering Heat	JIS C5202 6.4	Dip sample in a soldering bath at 260±5°C for 10±0.5 seconds Resistance value change within spec and no visual damage.
Solderability	JIS C5202 6.4	Dip sample in flux (methanol solution containing rosin approx. 25% in weight) for 2sec. and then dip into a soldering bath at 245±5°C for 2±0.5sec. Termination tinning ≥95% and no visual damage.
Bending	JIS C5202 6.1.4	Bend to 1,2 or 5mm according product type for 5s. Resistance value change within spec and no visual damage.
Load Life	JIS C5202 7.10; MIL-STD-202F METHOD 108A	At 70±2°C and rated working voltage for 1000 +24/-0 hours(42day). Resistance value change within spec and no visual damage.
Load Life Humidity	JIS C5202 7.5	At 40±2°C and 90~95% relative humidity, and subject to a voltage cycle consisting of rated working voltage of 1.5hrs on and 0.5hrs off for 1000 +24/-0 hours(42day). Resistance value change within spec and no visual damage.

包装数据

■ 磁带和卷轴包装

磁带和卷轴根据 IEC 包装规格 60286-3

Series	A	B	W	P0	P1	P2
CR0402	0.65±0.10	1.15±0.10	8.00±0.20	4.00±0.10	2.00±0.10	2.00±0.05
CR0603	1.10±0.10	1.90±0.10	8.00±0.20	4.00±0.10	4.00±0.10	2.00±0.05
CR0805	1.65±0.20	2.40±0.20	8.00±0.20	4.00±0.10	4.00±0.10	2.00±0.05
CR1206	2.00±0.20	3.60±0.20	8.00±0.50	4.00±0.10	4.00±0.10	2.00±0.05
CR1210	2.80±0.10	3.50±0.10	12.0±0.10	4.00±0.10	4.00±0.10	2.00±0.05
CR2010	2.90±0.20	5.40±0.20	12.0±0.10	4.00±0.10	4.00±0.10	2.00±0.05
CR2512	3.60±0.20	6.90±0.20	0.50±0.05	4.00±0.10	4.00±0.10	2.00±0.05
CA022A (0402*2)	1.15±0.20	1.15±0.20	8.00±0.20	4.00±0.10	2.00±0.10	2.00±0.05
CA024A (0402*4)	1.20±0.10	2.20±0.10	8.00±0.20	4.00±0.10	2.00±0.10	2.00±0.05
CA034A (0603*4)	1.90±0.15	2.40±0.20	8.00±0.20	4.00±0.10	4.00±0.10	2.00±0.05

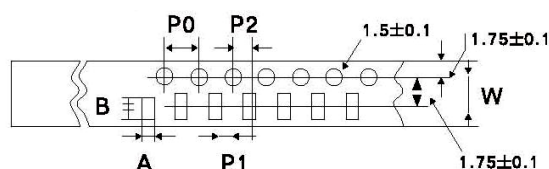
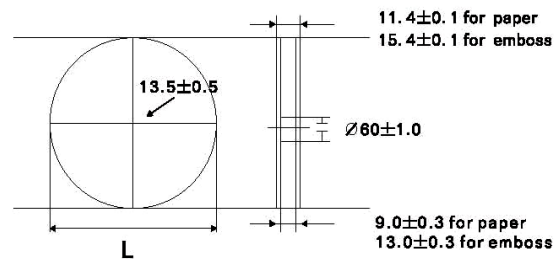

■ 磁带和卷轴包装

磁带和卷轴根据 IEC 包装规格 60286-3

Series	Quantity per Reel	Reel Size
CR0402	10,000	7" (Φ178mm)
CR0603	5,000	
CR0805	5,000	
CR1206	5,000	
CR1210	5,000	
CR2010	4,000	
CR2512	4,000	
CA022A (0402*2)	10,000	
CA024A (0402*4)	10,000	
CA034A (0603*4)	5,000	

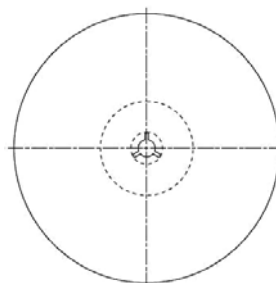

环境数据

■ 环保特性

1. 符合欧盟RoHS指令2002/95 / EC
2. 符合中国RoHS SJ/ T11363-2006
3. 符合无铅规范
4. 符合卤素控制
5. 电阻的均匀材料可能含有铅玻璃，属于欧盟RoHS指令的豁免



	Hazardous Substance or Element/ppm					
	Pb	Cd	Hg	Cr ⁶⁺	PBB	PBDE
	<1000	<100	<1000	<1000	<1000	<1000

	Halogen Substance/ ppm				
	F	Cl	Br	I	Total
	<900	<900	<900	<900	<1500

存储，处理和焊接数据

■ 存储和处理条件

1. 贮存条件：温度5-40℃，相对湿度30-75%RH
2. 保持化工及无尘的环境中，避免这样的硫化物和氯化物气体酸性气体
3. 避免直接暴露在阳光下

■ 推荐焊接条件

Recommended Profile Condition	Sn-Pb Soldering	Leadfree Soldering	Wave Soldering
Ramp-up rate (from pre-heat stage)	<3°C/s	<3°C/s	ΔT<150°C
Pre-heat Temperature & Time	100-150 °C 60-120s	150-200 °C 60-180s	100-150 °C 60-120s
Soldering Temperature & Time	183 °C 60-150s	217 °C 60-150s	260±5°C 5±2°C
Peak Temperature	230±5°C	245±5°C	260±5°C
Time within 5°C of peak temperature	10-30s	20-40s	-
Ramp-down rate	<6°C/s	<6°C/s	<6°C/s
Time 25°C to peak temperature	<6min	<8min	-
Manual Soldering: Approx. 350°C for 3s, avoid solder iron tip direct touch the components body			



型号

贴片电阻、贴片电阻阵列

CR	0805	J	8	0472	G
产品系列 CR: 贴片电阻 CA: 贴片电阻阵列	Size Code 0402 0603 0805 1206 1210 2010 2512 022A: 0402x2 024A: 0402x4 034A: 0603x4	Tolerance B: $\pm 0.1\%$ C: $\pm 0.25\%$ D: $\pm 0.5\%$ F: $\pm 1\%$ G: $\pm 2\%$ J: $\pm 5\%$ K: $\pm 10\%$ O: 0 Ω Jumper	Power Rating 1: 1W 2: 1/2W 3: 1/3W 4: 1/4W 8: 1/8W A: 1/10W F: 1/16W H: 1/32W -: Ignore	Resistance Value 49R9=49.9 0472=4K7 0103=10K 0564=560K	Special Code G: Reel V: Bulk D: Special Req