

VOLTAGE RANGE: 50 - 600V
CURRENT: 8.0 A

Features

- Low Reverse Recovery Time
- Low Leakage
- Low Forward Voltage Drop
- High Current Capability
- High Surge Capability
- Plastic Material - UL Flammability Rating 94V-0 High Reliability

Mechanical Data

- Case: TO-220A, Molded Plastic
- Terminals: Plated Axial Leads, Solderable per MIL-STD-202, Method 208
- Polarity: See Diagram at Right
- Approx. Weight: 2.24 grams
- Mounting Position: Any

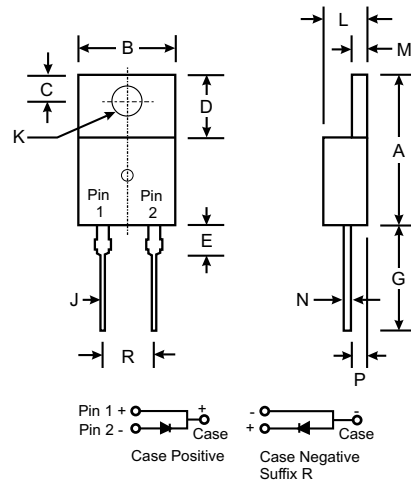

TO-220A		
Dim	Min	Max
A	14.22	15.88
B	9.65	10.67
C	2.54	3.43
D	5.84	6.86
E	—	6.25
G	12.70	14.73
H	2.29	2.79
J	0.51	1.14
K	3.53Ø	4.09Ø
L	3.56	4.83
M	1.14	1.40
N	0.30	0.64
P	2.03	2.92
R	4.83	5.33
All Dimensions in mm		

Maximum Ratings and Electrical Characteristics $T_A = 25^\circ\text{C}$ unless otherwise specified

Single phase, half wave, 60Hz, resistive or inductive load. For capacitive load, derate current by 20%.

Characteristic	Symbol	FR801	FR802	FR803	FR804	FR805	Unit
Maximum Recurrent Peak Reverse Voltage	V_{RRM}	50	100	200	400	600	V
Maximum RMS Voltage	V_{RMS}	35	70	140	280	420	V
Maximum DC Blocking voltage	V_{DC}	50	100	200	400	600	V
Maximum Average Forward Rectified Current 0.375" (9.5mm) Lead Length @ $T_C = 100^\circ\text{C}$	$I_{(AV)}$	8.0					A
Peak Forward Surge Current 8.3ms single half sine-wave superimposed on rated load (JEDEC Method)	I_{FSM}	150					A
Maximum Instantaneous Forward Voltage @ 8.0A DC	V_F	1.3					V
Maximum DC Reverse Current at Rated DC Blocking Voltage @ $T_A = 25^\circ\text{C}$	I_R	10					μA
Maximum Full Load Reverse Current Full Cycle @ $T_C = 100^\circ\text{C}$	I_R	150					μA
Maximum Reverse Recovery Time (Note 1)	T_{rr}	150				250	ns
Typical Junction Capacitance (Note 2)	C_J	70					pF
Operating and Storage Temperature Range	T_J, T_{STG}	-65 to +175					$^\circ\text{C}$

- Notes: 1. Reverse Recovery Test Conditions: $I_F = 0.5\text{ A}$, $I_R = 1.0\text{ A}$, $I_{RR} = 0.25\text{ A}$
 2. Measured at 1.0MHz and applied reverse voltage of 4.0V.

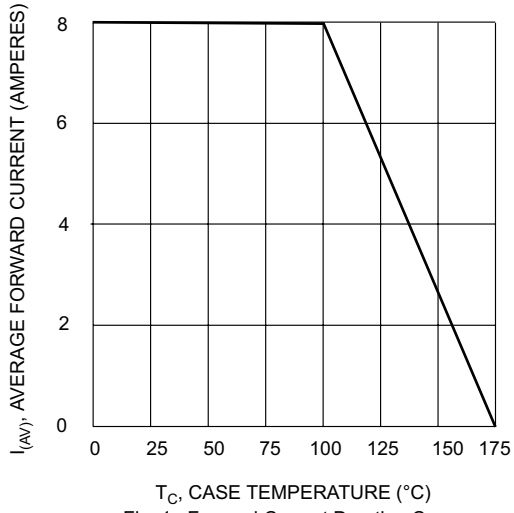

Fig. 1, Forward Current Derating Curve

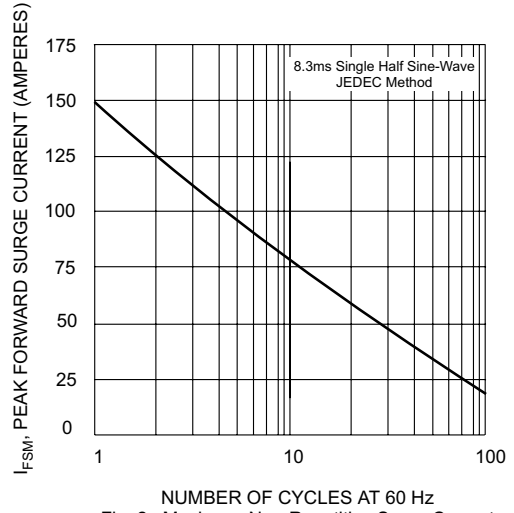

Fig. 2, Maximum Non-Repetitive Surge Current

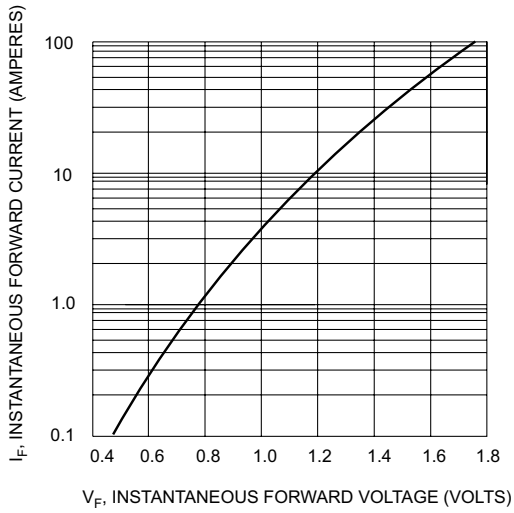

Fig. 3, Typical Instantaneous Forward Characteristics

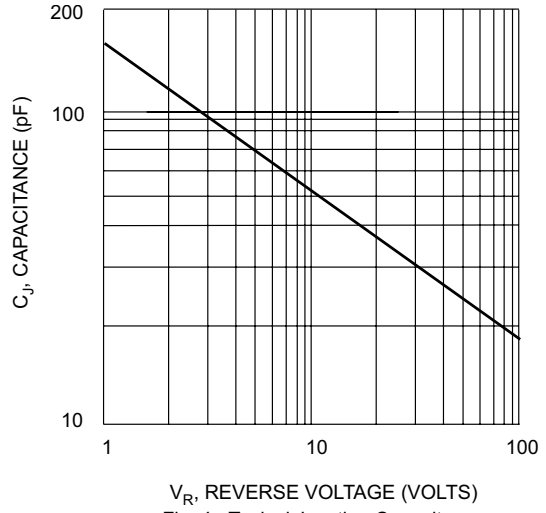

Fig. 4, Typical Junction Capacitance

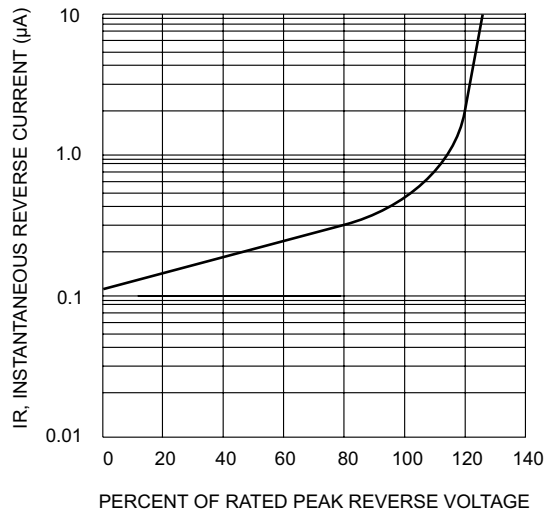

Fig. 5, Typical Reverse Characteristics